

**H-1100E<sup>TM</sup>**  
**Tub Grinder**  
**Serial Number G10140 & Up**

**Operating Instructions  
and Parts Reference**







**H-1100E**  
**TUB GRINDER**  
**OPERATOR'S MANUAL**  
**AND**  
**PARTS BOOK**

**SERIAL NUMBER G10140 AND UP**

## WARRANTY STATEMENT

DuraTech Industries (DuraTech Industries International, Inc.) warrants to its' authorized Haybuster dealer, who in turn warrants to the original purchaser for twelve (12) months from the purchase date. DuraTech Industries warrants that this Haybuster Product will be free from defects in material and workmanship when used as intended, under normal maintenance and operating conditions. This warranty is limited to the replacement of any defective part or parts returned to our factory in Jamestown, North Dakota, USA within thirty (30) days of failure.

This warranty shall become void if in the judgement of DuraTech Industries the machine has been subject to misuse, negligence, alterations, damaged by accident, lack of required normal maintenance, or if the product has been used for a purpose for which it was not designed.

All claims for warranty must be submitted through the dealer who originally sold the product and all warranty adjustments must be made through same.

This warranty does not apply to engines, clutches, batteries, tires, bearings, or any other trade accessories not manufactured by DuraTech Industries. The buyer must rely solely on the existing warranty, if any, of these respective manufacturers.

DuraTech Industries reserves the right to make changes in material and/or designs of this product at any time without notice.

This warranty is void if DuraTech Industries does not receive a valid warranty registration card at its office in Jamestown, North Dakota, USA within 10 days from date of original purchase.

All other warranties made with respect to this product, either expressed or implied, are hereby disclaimed by DuraTech Industries.

# **DURATECH INDUSTRIES INTERNATIONAL**

## **WARRANTY REGISTRATION**

( PLEASE PRINT IN INK )

CUSTOMER NAME \_\_\_\_\_

ADDRESS \_\_\_\_\_

CITY \_\_\_\_\_

CONTACT NAME \_\_\_\_\_

PHONE ( \_\_\_\_\_ ) \_\_\_\_\_

DEALERS NAME \_\_\_\_\_

DEALERS ADDRESS \_\_\_\_\_

---

---

### **MACHINE INFORMATION**

MACHINE MODEL H1100E

DATE PURCHASED \_\_\_\_\_

DELIVERY DATE \_\_\_\_\_

### **SERIAL NUMBER**

MACHINE # \_\_\_\_\_

ENGINE # \_\_\_\_\_

**VALID ONLY IF COMPLETED AND RETURNED  
WITHIN 14 DAYS OF PURCHASE TO:**

**DURATECH INDUSTRIES INTERNATIONAL, INC.**

**PO BOX 1940**

**JAMESTOWN, NORTH DAKOTA 58402-1940**

**This page left blank intentionally!**

# GRINDER DELIVERY AND SERVICE REPORT

- Dealer assisted the customer in filling out the warranty registration form
- The customer was provided with the appropriate engine operators manual and the grinder operators manual.
- The dealer read the operators manuals and explained in detail the operation, adjustment procedures, maintenance and safety instructions to customers.

After performing the necessary assembly, check the following items carefully and make corrections when necessary!

## CHECKED AND FOUND TO BE ACCEPTABLE:

- Check the H1100E Tub Grinder for shipping damage or shortage.
- Check the machine for loose bolts.
- Lubricate entire machine according to the lubrication chart found on pages 21-23.
- Check engine oil level.
- Check engine coolant.
- Check batteries.
- Check air cleaner for obstructions.
- Check exhaust for obstructions.
- Read Engine Pre-Start-up check list in engine operation manual.
- Check clutch adjustment.
- Check hydraulic oil level, page 4.
- Check hydraulic connections for tightness.
- Check for correct hammer arrangement, page 31.
- Check for proper function of tub rotation control valve.
- Check for proper function of electronic governor, page 15.
- Check all chains for proper alignment.
- Check all chains for proper tension.
- Check conveyor belt tracking, page 27.
- Check conveyor belt tension, page 27.
- Check condition of tire rims.
- Check wheel lug bolts for tightness.
- Check tires for proper air pressure, page 24.
- Check lights for proper function.
- Check brakes for proper function.
- Check the hydraulic components for leaks.
- Verify that all shields are installed and in good condition.
- Pointed out all safety shields and explained the importance of keeping all safety shields and covers securely in place.
- Check condition of all safety, operation, and maintenance decals.

I have checked all the items and test run the machine.

THIS MACHINE IS READY FOR CUSTOMER USE.

Dealer's signature. \_\_\_\_\_

Customer's signature. \_\_\_\_\_ Date \_\_\_\_\_

Model No. H1100E Serial No. \_\_\_\_\_ Date Of Purchase \_\_\_\_\_

Please return this report with the Warranty Card.

# **GRINDER DELIVERY AND SERVICE REPORT**

This page left blank intentionally!



# TABLE OF CONTENTS

<b>INTRODUCTION .....</b>	<b>3</b>
<b>SHIPPING AND DELIVERY INSTRUCTIONS .....</b>	<b>4</b>
<b>SPECIFICATIONS.....</b>	<b>6</b>
<b>SAFETY INSTRUCTIONS.....</b>	<b>7</b>
<b>SAFETY INSTRUCTIONS.....</b>	<b>8</b>
SAFETY DECALS.....	8
BEFORE OPERATING .....	8
DURING OPERATION .....	9
NORMAL SHUTDOWN PROCEDURE.....	9
EMERGENCY SHUTDOWN PROCEDURE.....	9
THROWN OBJECT ZONE.....	10
FIRE PREVENTION.....	11
FIRE EXTINGUISHERS .....	12
<b>BEFORE OPERATING.....</b>	<b>13</b>
PRE-STARTING INSPECTION INSTRUCTION .....	13
CHOOSING PROPER SCREEN .....	14
INSTALLING A SCREEN .....	14
<b>OPERATION.....</b>	<b>15</b>
INTRODUCTION .....	15
GRINDING.....	15
CLUTCH .....	16
CLUTCH ADJUSTMENT .....	17
TRANSPORTING .....	17
TUB FINS.....	17
<b>MURPHY SYSTEM OPERATION .....</b>	<b>18</b>
<b>ELECTRONIC GOVERNOR OPERATION.....</b>	<b>19</b>
INTRODUCTION .....	19
CALIBRATION .....	19
TYPICAL ELECTRONIC GOVERNOR SYSTEM.....	20
TROUBLE SHOOTING ELECTRONIC GOVERNOR SYSTEM.....	21
ELECTRONIC GOVERNOR HARDWARE TEST.....	23
ELECTRO-HYDRAULIC VALVE COIL TEST .....	24
MANUAL OVERRIDE.....	24
<b>TROUBLESHOOTING MICROTRONICS WIRELESS REMOTE CONTROLS..</b>	<b>25</b>
Transmitter Battery .....	25
Receiver / Transmitter Communication Check.....	26
Antenna and Cable Check.....	27
Engine Shutdown Check.....	28
Conveyor Up and Down Check .....	28
Tub Forward and Tub Reverse Check .....	28
<b>LUBRICATION .....</b>	<b>30</b>
HYDRAULIC OIL .....	30
BEARING LUBRICATION.....	30

<b>MAINTENANCE .....</b>	<b>33</b>
SERVICE AND MAINTENANCE.....	33
HAMMERMILL.....	34
CONVEYOR BELTS.....	36
ROTOR BEARING.....	37
TUB CHAIN DRIVE.....	38
<b>TROUBLE SHOOTING .....</b>	<b>39</b>
<b>HAMMER SPACING .....</b>	<b>40</b>
<b>PARTS BOOK TABLE OF CONTENTS .....</b>	<b>42</b>

# INTRODUCTION

**READ THIS MANUAL CAREFULLY TO LEARN HOW TO OPERATE AND SERVICE YOUR MACHINE CORRECTLY. FAILURE TO DO SO COULD RESULT IN EQUIPMENT DAMAGE AND MAY VOID THE WARRANTY.**

The purpose of this owners manual is to familiarize the owners and operators with the H-1100E and to explain routine maintenance and adjustments for most efficient operation of your H-1100E tub grinder. Included is a troubleshooting section which may help in case of problems in the field. Any information not covered in this manual may be obtained through your dealer.

When reference is made to the front, rear, left, and right of the machine, the reference is always made standing at the conveyor end of the machine looking towards the hitch.

Always have your serial number and model number of your machine when referencing parts and communicating with dealers and service people.

Model Number **H-1100E**

Serial Number \_\_\_\_\_

The H1100E grinder is designed to grind material into more palatable or manageable rations for your operation. It has multiple uses:

1. Grind most types of hay
  - Big round bales
  - Loose hay
  - Square bales
2. Grind most types of grain
  - Ear corn
  - Shell corn
  - High moisture corn
  - All small grains
3. Grind roughage's into various sizes
  - Screens are available from 1/8" to 8"
  - Combine screen sizes to get desired cut

DURATECH with logo and HAYBUSTER with Sunburst are registered trademarks of Duratech Industries International, Inc.

# SHIPPING AND DELIVERY INSTRUCTIONS

**DEALER CHECKLIST:** Check off **PRE-DELIVERY** each item as it is found satisfactory or after the correction has been made.

- ◇ Check machine for shipping damage or shortages.
  - ◇ Grinder has been properly assembled.
  - ◇ Tires are inflated to proper pressure.
  - ◇ Wheel bolts are tightened to 450 ft-lb. to 500 ft-lb.
  - ◇ Grinder has been properly lubricated. Page 30.
  - ◇ Hydraulic connections do not leak.
  - ◇ Grinder responds correctly to controls. Electronic governor working properly.
  - ◇ Hydraulic oil level is correct.
  - ◇ Scratches are all painted.
  - ◇ All shields are in place and decals are readable.
  - ◇ Check hammer arrangement and for proper clearance hammer to screen.
  - ◇ Check-out machine for any excessive vibration with rotor at proper rpm..
  - ◇ Check tub carrier rollers and pressure rollers for proper alignment.
  - ◇ Check tub drive chain for proper operation in sequence with tub teeth.
  - ◇ Check clutch adjustment.
- This grinder has been pre-run and to the best of my knowledge is ready to deliver to the customer.
- Date delivered: \_\_\_\_\_
- Signature: \_\_\_\_\_

---

**DELIVERY CHECKLIST:** Review the operators manual with the customer and explain the following:

- ◇ DuraTech Industries International, Inc.(DuraTech Industries) warranty
- ◇ Safe operation and service. Page 6.
- ◇ Grinder controls and operation. Page 13.
- ◇ Importance of correct hydraulic level. Page 4.
- ◇ Daily and periodic lubrication and maintenance. Page 30.
- ◇ DuraTech Industries parts and service
- ◇ Advise the customer not to operate machine with any shields or guards removed.
- ◇ Electronic Governor operation. Pages 18 - 24.
- ◇ Record serial number on Introduction page of this manual.
- ◇ Encourage the customer to read the Operations Manual
- ◇ Give the customer the Operations Manual

# SHIPPING AND DELIVERY INSTRUCTIONS

**NOTE:** All machines have been pre-run at the factory to assure all functions are performing correctly. The hydraulic reservoir contains approximately 56 gallons of hydraulic oil. The oil level should be up to the oil level decal on the front of the hydraulic tank. Verify that the hydraulic oil level is correct. Add if necessary.

**CAUTION:** Lack of proper oil level in the reservoir tank will cause system to heat under continuous running. (Recommend Conoco Hydroclear Power Tran Fluid or similarly rated hydraulic oil.)

# SPECIFICATIONS

## H-1000E SPECIFICATIONS

Weight Total.....	22,340 LB.
Axle Weight.....	18,640 lb.
Tongue weight.....	3,700 lb.
Transport width.....	11 ft.
Transport height.....	11 ft. 8in
Loading height.....	9ft. 2in.
Length in transport.....	38ft. 6in.
Axles.....	2 - 10K with Dual Tires
Brakes.....	Electric
Tires.....	(8) 9.50R 16.5LT
Towing Arrangement Conveyor.....	Gooseneck
Fuel Capacity.....	168 Gallons
Hydraulic Oil Capacity.....	45 Gallons
Lights.....	Clearance, Direction, and Brake

## TUB FEATURES

Tub Width.....	11 ft.
Depth.....	50 in.
Tub Diameter at Base.....	9 ft.
Tub Wall.....	12 Gauge
Tub Floor.....	10 Gauge
Tub Drive.....	Hydraulic Orbit Motor
Service Access.....	80 Degree Tilt Tub

# SPECIFICATIONS CONT.

## CONVEYORS

Discharge Conveyor.....	26' Long x 18" Wide Hydraulic Driven
Belly Conveyor.....	30" Wide Hydraulic Driven
Tub Speed Sensor.....	Electronic Governor
Safety Switches.....	Safety Shutdown

## ROTOR

Length.....	50"
Feed Opening.....	25" x 52"
Cylinder Plates.....	16" Diameter, 1/2" thick
Cylinder Shaft.....	4-1/2" Stress Proof Steel
Drive.....	Direct Drive
Bearings.....	3" Pillow Block Bearings
Hammers.....	1/2" Hardened Swing
Rods.....	1-1/4" Case Hardened
Screens.....	1/4" Thick, Various Sizes
Screen Area.....	2563 Square Inches
Engine.....	300 to 460 HP

---

### ***AVAILABLE OPTIONS FOR DURATECH INDUSTRIES***

#### ***MODEL H1100E TUB GRINDERS:***

- 214 Gallon Fuel Capacity
- Air Brakes
- Air Compressor Kit
- Ear Corn Kit
- Geyser Plate
- Grain Grinding Hopper
- Loose Hay Guide
- Mill Grate
- Radio Remote Control
- Tub Seal Kit
- Various Screen Sizes
- Work Light Kit

# **SAFETY INSTRUCTIONS**

**THIS GRINDER IS NOT TO BE USED FOR ANY PURPOSE OTHER THAN AS EXPLAINED IN THE OPERATOR'S MANUAL, ADVERTISING MATERIALS, AND OTHER PERTINENT WRITTEN MATERIAL PREPARED BY DURATECH INDUSTRIES.**

**WARNING: FAILURE TO COMPLY WITH SAFETY INSTRUCTIONS COULD RESULT IN PERSONAL INJURY OR DEATH.**

**WARNING: BEFORE OPERATING YOUR GRINDER, CAREFULLY READ AND FOLLOW INSTRUCTIONS GIVEN BELOW AND CONTAINED ELSEWHERE IN THIS MANUAL.**

---

## **SAFETY DECALS**

The safety decals located on your machine contain important and useful information that will help you operate your equipment safely.

To assure that all decals remain in place and in good condition, follow the instructions below:

1. Keep decals clean. Use soap and water- not mineral spirits, adhesive cleaners or similar cleaners that will damage the decal.
2. Replace all damaged or missing decals. When attaching decals, surface temperature of the machine must be at least 40 degrees F. The surface must also be clean and dry.
3. When replacing a machine component to which a decal is attached, be sure to also replace the decal.
4. Replacement decals can be purchased from your DuraTech Industries dealer.

## **BEFORE OPERATING**

1. Read and follow all instructions contained in:
  - Operators Manual
  - Decals placed on machine
2. Allow only responsible, properly instructed individuals to operate your machine.
3. Make sure the machine is in good operating condition and that all protective shields are in place and in proper working order. Replace damaged shields before operating.
4. Be sure all bystanders and other workers are clear before starting engine and grinder.
5. Make no modifications to the machine unless specifically recommended or requested by DuraTech Industries.
6. Check periodically for breaks or unusual wear and make necessary repairs.
7. Be sure the unit is securely attached to towing vehicle during grinder operation and road transport.
8. Keep engine compartment clean. Remove all debris from compartment, especially anywhere on the engine.



# SAFETY INSTRUCTIONS

## DURING OPERATION

1. Enforce the following safety precautions to prevent serious personal injury or death due to accidental contact with grinder.
  - Everyone must be kept clear of work area except an operator properly located at the controls.
  - Disengage clutch and make sure everyone is clear of machine before starting engine.
  - Never work on or near grinder unless normal shutdown procedure has been followed and all motion has stopped.
  - An approved hard hat and safety glasses must be worn by all personnel within a 500 ft. radius of the operating machine.
2. Keep hands, feet, and clothing away from power driven parts.
3. Never leave controls unattended while engine is running. Shutdown engine when leaving the operator control areas.
4. Keep shields in place and in good condition.
5. Watch out for and avoid any object that might interfere with the proper operation of the machine.
6. Loose clothing, necklaces, and similar items are more easily caught in moving parts. Avoid the use of these items and keep long hair confined.
7. **NEVER ENGAGE HAMMERMILL WHEN TUB IS RAISED.**

## NORMAL SHUTDOWN PROCEDURE

For your safety and the safety of others, you must use the following normal shut-down procedure before leaving the controls unattended for any reason, including servicing, cleaning, or inspecting. A variation of the following procedure may be used if so instructed within this manual or if an extreme emergency requires it.

1. Grind out as much material as possible from the tub. Stop tub rotation.
2. Disengage rotor clutch.
3. Stop discharge conveyors.
4. **After the rotor has stopped completely**, the material remaining in the tub may be dumped by tilting the tub platform. Make certain that all personnel are clear of the area before performing this operation. A bale can roll or tumble a great distance before coming to rest after being dumped from the tub.
5. If the tub is to remain in the tilted position, make certain it is fully raised and insert the hydraulic cylinder block. If the tub is to be lowered again, do so at this time. **Never work on the machine with the tub partially raised.**
9. Shut engine down. Remove key. Tag the switch to prevent other personnel from accidentally starting the machine during servicing.
10. Clean engine compartment. Remove all debris from compartment, especially anywhere on the engine.

## EMERGENCY SHUTDOWN PROCEDURE

1. Press emergency stop button to shut down engine and all functions.

# SAFETY INSTRUCTIONS

## THROWN OBJECT ZONE

An operational characteristic of all tub grinders is that objects may be thrown out of the tub. Thrown objects may present a safety hazard to persons in the area. This section is to inform the operator of this characteristic, and what can be done to reduce the risk of injury to the operator and persons in the area.

Figure 1 shows an object being hit as the hammer is on the upswing. A general pattern for where thrown objects may land is shown in Figure 2. Note the difference in the size of the area for side A versus side B. Side B is larger.

Dimensioning the size of this area is not practical. The distance a thrown object may travel is dependent on several conditions, including, but not limited to, rotor speed and diameter, condition of the hammers, style of hammers, object mass, object shape, amount of material in the tub, and how the hammer strikes the object.

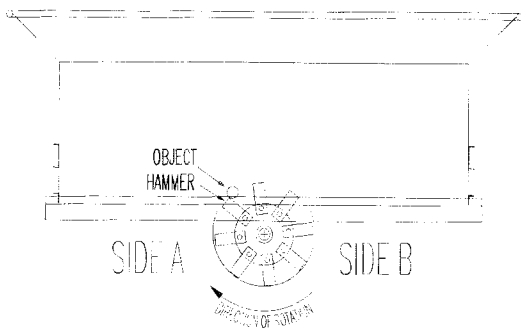

Figure 1 Tub Cross Section

The amount of material in the tub can dampen or stop the object's potential flight. Keeping the tub full will reduce the risks. Filling the tub at least 1/2 full when starting will reduce the risk. A risk may arise when the tub is being emptied, such as at the end of the grind. Running the engine at slower speeds when starting or finishing the grind will also help, especially slowing down when emptying the tub.

### To minimize the potential risk of injury, the operator must:

- place side B towards open areas, away from property and people.
- load the grinder on side A with a loader equipped with an enclosed cab.
- keep the tub full.
- keep observers out of the areas.
- wear a hard hat and safety glasses, at a minimum, and require that any other persons in the areas are similarly equipped.

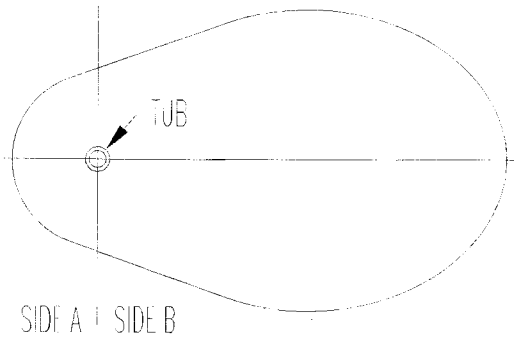

Figure 2, Thrown Object Zone

# SAFETY INSTRUCTIONS

## FIRE PREVENTION

Grinding wood, hay, and other products in a tub grinder produces a large amount of potentially combustible material. The risks of fire can be significantly reduced with proper operating and maintenance procedures. This does include frequent removal of dust, debris, and other combustible materials.

Most of the products that are ground are dry and the grinding process can produce fine, dusty material. The grinding process can produce heat and the spinning rotor will circulate air within the grinding chamber. For a fire to start, fuel, oxygen and heat in sufficient quantity, must be present. During normal operation and with a properly maintained tub grinder, the material being ground will move through the grinding chamber so quickly that it doesn't have a chance to heat up sufficiently to start a fire. Also, the rapid rate that a tub grinder can pile material will quickly smother small hot spots that might occur during normal grinding operations. Keeping the material moving through the machine and across the top of the rotor is important to keep frictional heating of the material to a minimum.

**Never leave the vicinity of the unit with the engine running.**

### PROPER OPERATION OF THE TUB GRINDER:

- Do not grind materials any finer than necessary. Finely ground materials will produce more dust and increase the risk of fire. If finely ground materials are required, it is better to grind the materials coarse first with large opening screens installed in the grinder and then regrind them to the desired consistency by installing smaller opening screens in the grinder. Be especially cautious when grinding materials that can burn easily.
- When filling the tub grinder during start-up begin by filling the rear of the tub and avoid placing materials on the spinning rotor. When material begins to fall over the rotor, set the governor control on "Manual" and rotate the tub slowly while continuing to fill the tub. Use the tub cover to control thrown objects as much as possible. When the tub is 1/2 to 2/3 full, the governor control can be set to "auto" and grinding operations can resume normally. Do not allow the tub to stop for any significant amount of time with material over the rotor to minimize frictional heating.
- Do not smoke when working with combustible materials.

### REMOVAL AND CLEANING INSTRUCTIONS:

- Clean the engine compartment daily or more often if conditions require it be done more frequently. When cleaning the engine compartment, always clean the top of the engine and the areas around exhaust manifolds, exhaust plumbing and turbochargers.
- Check the rotor box for debris built up around the rotor. Remove material that may be packed tight near the bearings, on shaft or other rotating components because it will become hot due to friction.
- At shutdown, always clean and remove all dust, debris, or combustible material off the entire grinder. Use high-pressure air or water if necessary. Always move the grinder and all other equipment away from the ground material pile before leaving the job site in case of smoldering combustion in the ground material.

### TUB GRINDER MAINTENANCE:

- Repair any fuel or hydraulic leaks as quickly as they are discovered. Clean up spills immediately. Fuel or oil soaked materials can contribute significantly to the rapid spreading of a fire once it has begun.
- Inspect all electrical wiring periodically. Any chafed or damaged wires should be repaired immediately. Keep all electrical connections tight to prevent arcs or sparks.
- Contact between the rotor and any stationary component of the grinding chamber such as contact between the hammers and the screens must be corrected immediately.

# SAFETY INSTRUCTIONS

## FIRE EXTINGUISHERS

Fire extinguishers are provided on all DuraTech grinders in the unlikely event that a fire does start on the grinder. An extinguisher is located on both sides of the machine near the front of the engine compartment. The extinguishers are ABC dry chemical extinguishers that are appropriate for use with all materials normally encountered on a tub grinder.

If a fire does start, CALL THE LOCAL FIRE DEPARTMENT IMMEDIATELY. Then, use the fire extinguisher if you feel confident that you can extinguish the fire. A 10# extinguisher will last about 15-20 seconds and a 20# extinguisher will last about 20-24 seconds, so they will not stop a large fire.

When using a fire extinguisher, use the P A S S method:

- Approach the fire with the wind at your back.
- Pull the pin,
- Aim the spout.
- Squeeze the trigger, and
- Sweep along the base of the fire from about 6-8 feet away.

Read the label on your extinguisher now, most extinguishers have descriptions of this method, and an estimated working time.

If an extinguisher is only partially used, the dry chemical will jam in the seals, allowing the extinguisher to lose its pressure charge in less than an hour, making it useless to you. It must be recharged before placing it back on the machine. Have the extinguisher recharged today; a fire will not wait for you to recharge your extinguisher tomorrow!

Fire extinguishers should be inspected and recharged by a professional at least annually to keep them at optimum performance! A "verification of service" collar that confirms the month and year of service should be attached to the neck of the container to confirm when the extinguisher was last serviced.

# BEFORE OPERATING

## PRE-STARTING INSPECTION INSTRUCTION

To insure long life and economical operation - Learn how to operate the machine and how to use controls properly. Thoroughly instruct operator in maintenance and operation of machine. There is no substitute for a sound preventative maintenance program and a well-trained operator. Visually inspect the machine before starting the grinder. This can be done as the lubrication is being carried out. Any items that are worn, broken, missing or needing adjustment must be serviced accordingly before operating the grinder.

**WARNING: Before inspecting the machine, use the normal shut-down procedure found on page 9.**

## PRE-OPERATING CHECKS

Before operating the Tub Grinder, follow these instructions:

1. Read and have a thorough understanding of the operator's manual.
2. Learn how to operate and how to use controls properly. Do Not let anyone operate without instruction.
3. Know the machine's safety features and understand the safety precautions.
4. Be sure all lubrication has been carried out as recommended. **See lubrication chart.**
5. Give the machine a "once-over" for any loose bolts. Make sure machine is properly adjusted.
6. Check hydraulic oil level.

**WARNING: Hydraulic fluid escaping under pressure can be almost invisible and can have sufficient force to penetrate the skin. When searching for suspected leaks, use a piece of wood or cardboard rather than your hands. If injured, seek medical attention immediately to prevent serious infection or reaction.**

7. Check hydraulic components for leaks or damage.
8. Visually examine rotor to see if any parts have excessive wear. These parts include

shaft, plates, rods, hammers and moveable plate.

9. Check screens, screen hold downs, for wear and tightness.
10. Check installation and condition of hammers.
11. Visually examine rotor bearings and mounting bolts.
12. Check all bearings for wear.
13. Make sure all shields and guards are in place.
14. Check lug nuts for tightness.
15. Check condition of tire rims.
16. Check tires for proper air pressure.
17. Chains and belts for proper tension and condition.
18. Condition of decals.
19. When preparing to grind, always place the machine on level ground.  
Check for obstructions, raising the tub, unfolding the conveyor, and tractor operation  
Position grinder to minimize risks thrown objects. See page 10 for details.
20. Start the machine and check the tub direction, speed control governor for proper operation.
21. In cold weather, allow five minutes for the machine to warm up before grinding.
22. Watch for unusual or excessive vibration. If any occur immediately shut off the power. Check to see what is wrong and correct it before starting the grinder again.
23. Check clutch adjustment
24. Clean engine compartment.

**CAUTION: The kinetic energy in the rotor causes it to rotate long after the engine has been disengaged. Before performing any maintenance on the machine or getting into the tub, be sure rotor and all moving parts have come to a complete stop.**

# BEFORE OPERATING

## CHOOSING PROPER SCREEN

The coarseness of the material to be ground is determined by the hole size in the screens. Hole sizes can vary from 1/8" diameter through 8" diameter. The larger the hole diameter the coarser the grind.

All DuraTech Industries grinders have two screens. Any combination of hole sizes may be used.

**If a combination is used, the smallest hole diameter should be placed on the left hand side of the rotor box where the forage enters the rotor.**

The size of the perforation in the screen determines the fineness of grind. In general, larger screen sizes are used for grinding hay.

Round perforated screens available are: 1/8", 3/16", 1/4", 3/8", 1/2", 5/8", 3/4", 1", 1-1/2", 2", 3", 4", 5", 6", 7", and 8".

Slotted screens and dummy screen sizes are available:

As a general guide, the following screen sizes are recommended:

Hay.....	2" to 8"
Ear Corn.....	5/8" to 1"
Shelled Corn.....	3/4" dry, 5/8" high moisture
Small Grains.....	1/4" to 3/8"

**CAUTION: Keep all foreign objects out of the tub and away from the rotor. Foreign objects thrown from machine may result in personal injury or damage to the machine .**

## INSTALLING A SCREEN

**CAUTION: Follow normal shutdown procedure before entering tub to do any service work.**

1. Tilt tub up and install cylinder safety stop. Remove bolts on hold down straps from each corner and flip open.
2. With a large hook or bar, pull the screen from its chamber.
3. Make sure material is clear from screen track.
4. Install the new screen.
5. Replace holdown straps and secure with bolts removed in step #2.
6. Remove cylinder safety stop and lower tub platform.

**NOTE: Check hammer to screen clearance before operating grinder. Damage to screens by improper clearances is not covered under warranty.**

**NOTE: A fire extinguisher should be handy at all times due to the possibility of sparks from engine exhaust or hammers hitting a foreign object.**

# OPERATION

## INTRODUCTION

The engine is direct coupled to the rotor so the engine speed is equal to the rotor speed. The recommended engine / rotor speed is between 1700 and 2000 rpm. Use the lower end of the recommended range to improve the aggressiveness of the rotor and to improve fuel efficiency. If the engine is loaded heavily, increase the rpm.

The Electronic Governor controls the tub speed / feed rate to keep the engine at its peak operating range. The operator is able to select the operating range on the electronic governor control so when the feed of material lugs the engine, the Electronic Governor will reduce or stop the feed. The Electronic Governor maintains the rotor at a high enough rpm for the engine to recover automatically when a slug of material is encountered. The Electronic Governor may require adjustment when changing operating speed as described in the previous paragraph.

## GRINDING

- Release engine shutdown push-button.
- Start the engine and set throttle at 1000 rpm.
- Allow the engine to warm up for a few minutes.
- Unfold the discharge conveyor and set to desired height.
- Engage conveyor run valve to forward position.
- Engage the **rotor clutch**. Pull firmly on lever when engaging clutch, then release to allow engine to recover. Repeat until clutch can be fully engaged without stalling engine (Usually on the third try). Do not allow clutch to slip excessively.

Throttle engine to desired operating speed between 1700 and 2000 rpm. Materials to be ground should be placed directly into the tub.

**The best method for filling the tub is:**

**WARNING: DO NOT DROP MATERIAL DIRECTLY ON ROTOR AS DAMAGE MAY RESULT.**

- Fill the tub about half full of unground materials before starting tub rotation.
- Start tub rotation in the forward direction by switching the **electronic governor switch** to **on** and pushing the **tub control valve lever**.
- As materials are ground away, place additional materials in the tub to prevent or reduce geysering material.

## LOOSE HAY

The best capacity will be obtained if the tub is consistently kept no less than half full of loose hay. When loading the tub, place materials slightly to the rear rather than directly over the rotor. An optional hay guide attachment should be used to guide large quantities of loose hay into the tub (see Optional Equipment section). For best results feed the tub with small portions.

## WET OR FROZEN HAY

This is the toughest material for any grinder to handle. When filling the tub with wet or frozen hay, deposit small quantities on a more frequent basis rather than filling the tub with one load.

## LARGE ROUND BALES

Large round bales can be placed in the tub on end or on the side. Try grinding bales each way to determine which method will work best for you. Before placing a large bale into the tub, place about 1 to 2 feet of loose hay in the bottom of the tub. This practice keeps the bale from lodging in the center of the tub.

**IMPORTANT:** Never drop a large round bale into the tub from a high level. Ease the bale over the edge and down into the tub carefully. Dropping a large bale directly on top of rotor will cause damage to the rotor.

# OPERATION

## CROP RESIDUE

When grinding crop residues, use the same methods as with loose hay. Extremely wet or frozen materials should be placed sparingly into the tub.

## SMALL GRAINS

Grinding small grains requires special attachments. These attachments fit directly over the rotor. It is not recommended that small grains be ground without the use of one of the small grain attachments. (See Optional Equipment section.)

## EAR CORN

Grinding ear corn requires a special attachment. This attachment fits directly over the rotor and allows flow to the rotor to be regulated by regulating tub speed. (See Optional Equipment section.)

## SHUTDOWN

- Grind out as much material as possible from the tub.
- Stop tub rotation by moving the tub valve to the neutral position.
- Switch the **electronic governor** to **off**.
- Disengage the rotor clutch.
- Stop discharge conveyors by moving conveyor run valve to the neutral position.

After the rotor has stopped completely, the material remaining in the tub may be dumped by tilting the tub platform. Make certain that all personnel are clear of the area before performing this operation. A bale can roll or tumble a great distance before coming to rest after being dumped from the tub.

- Return tub platform to full down position.
- Fold the discharge conveyor.
- Shut down engine by switching off engine ignition switch.
- Remove key from engine control panel.

## LODGED MATERIAL

**DANGER:** Never attempt to dislodge material inside the tub by physically entering the tub when the machine is in operation. **WHEN THE MACHINE IS IN OPERATION, STAY OUT OF THE TUB!**

Occasionally materials may lodge against the side of the tub and not feed down to the rotor. If this occurs, reverse the tub direction briefly and then start the tub in a clockwise direction again. The tub rotation can be reversed by moving tub control valve to the reverse position. This practice normally dislodges any materials.

## FOREIGN MATERIAL

Foreign material, such as scrap metal, in the rotor area can cause severe damage to hammers, screens, hammer rods, and other parts and may cause extensive part failures.

**NOTE:** A fire extinguisher should be handy at all times due to the possibility of sparks from engine exhaust or hammers hitting a foreign object.

## CLUTCH

**IMPORTANT:** Read and have a thorough understanding of the clutch operator's manual, and specification plate found on clutch housing.



# OPERATION

**IMPORTANT: DO NOT engage clutch at high engine rpm. Before starting engine, rotor box should be cleared of all material. Set engine below 1000 rpm. Push firmly on lever when engaging clutch, then release to allow engine to recover. Repeat until clutch can be fully engaged without stalling engine (Usually on the third try). Do not allow clutch to slip excessively. Run without grinding for a few minutes to allow the clutch plates to cool off. Check periodically for proper adjustment according to spec. plate on clutch housing.**

## CLUTCH ADJUSTMENT

CLUTCH - if the clutch slips, overheats, or the clutch operating lever jumps out, the clutch must be adjusted. To adjust the clutch, follow instructions on clutch access cover.

A new clutch generally requires several adjustments until the friction surfaces are worn in. Do not let a clutch slip as this will glaze the friction plates and may ruin them.

**CLUTCH DAMAGE DUE TO EXCESSIVE SLIPPAGE WILL NOT BE COVERED BY WARRANTY.**

## TRANSPORTING

1. Grind out as much material as possible from the tub. Stop tub rotation.
2. Disengage rotor clutch.
3. Stop discharge conveyors.
4. **After the rotor has stopped completely**, the material remaining in the tub may be dumped by tilting the tub platform. Make certain that all personnel are clear of the area before performing this operation. A bale can roll or tumble a great distance before coming to rest after being dumped from the tub
5. Return tub platform to full down position.

6. Be sure any loose parts (replacement hammers and screens, etc.) are securely fastened down.
7. Fold the conveyor to transport position.
8. Shut engine down. Turn off and remove key.
9. Hitch grinder to a towing vehicle with adequate load carrying and braking capacity. Only CDL qualified personnel should hitch this machine to a towing vehicle.
10. Check the turning clearance between the grinder and the towing vehicle.

## TUB FINS

Two tub fins are furnished with the grinder.

When grinding large round bales, use only one of two tub fins, bolted in the upper position. Two tub fins across from each other may hold the bale up and reduce capacity.

When grinding small round bales, square bales or loose hay use two fins bolted in the lower position.

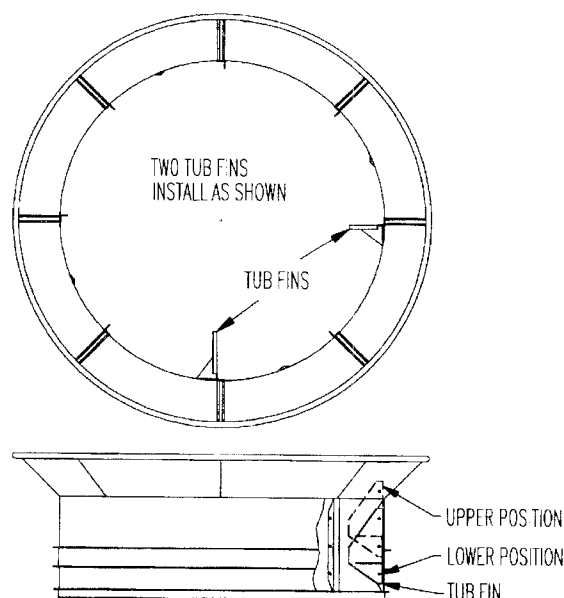

# MURPHY SYSTEM OPERATION

There are 5 terminals on the bottom of the 518PH Murphy relay. There are 6 terminals on the bottom of the 518APH Murphy relay. Both types are used on Caterpillar engines equipped with remote mounted Murphy panels. 24VDC power is supplied from the key switch from the IGN terminal when the key is in the run position. The power passes through a panel-mounted fuse and enters the Murphy relay at terminal [B]. When the override button is depressed, power is available at the [NC] terminal and at the [SW1] terminal. There is a resistor (400-ohm) between [NC] and [SW1]. Power returns to the relay through terminal [SW2] (Approx. 10 VDC is measured by a voltmeter at [SW2] when the relay is installed in the grinders), which keeps the relay latched electrically (Closed Loop circuit). The fifth terminal is the ground [G] terminal. The sixth terminal found only on the 518APH is the [NO] terminal which will be energized when the Murphy relay is unlatched and the key switch is in the run position. The sixth terminal [NO] is not used on the DuraTech Industries tub grinders.

On the Caterpillar engines, power must be supplied to the fuel supply valve in order for the engine to run. The fuel supply valve is connected to the [NC] terminal of the Murphy relay so, power is only supplied to the fuel valve when the Murphy relay button is pushed in and the key switch is in the run position. The oil pressure SWITCHGAGE, the water temperature SWITCHGAGE, the tub tilt interlock system, and all emergency stop buttons are connected to the Closed Loop circuit which is connected from [SW1] to [SW2] on the Murphy relay. Any of the above controls can shut the engine down by connecting the Closed Loop circuit to “ground” (usually a local frame ground). This will “short circuit” the power that is emitted from [SW1] directly to ground and no power will return to [SW2]. This will cause the Murphy relay to unlatch and power will be shut off to the fuel supply valve, causing the engine to shutdown. The 400-ohm resistor in the Murphy relay reduces the voltage to approximately 10 VDC so arcing is minimized when a shutdown signal is activated. Also, any “inadvertent ground” in any wire of the Closed Loop or loss of power in the Closed Loop will cause the Murphy Relay to unlatch and the engine will shut down.

# ELECTRONIC GOVERNOR OPERATION

## INTRODUCTION

The Model RCB93 Electronic Governor automatically controls the feed rate to keep the engine its optimum power zone. (“engine mode”) When the load on the grinding rotor begins to lug the engine, the governor automatically reduces tub rotation speed in proportion to the load. The result is nearly a constant load on the engine, which will maximize grinding efficiency.

The RCB93 Electronic governor will also perform as a simple tub speed control. (“tub” mode) In this mode the tub speed is constant and it will not change to match varying load conditions.

**IMPORTANT: Always use the automatic mode (“engine mode”) except when calibrating or trouble shooting the electronic governor.**

When the electronic governor is switched to the engine mode, it is monitoring the rotation speed of the engine. The hydraulic flow to the tub drive mechanism is regulated proportionally to the engine speed. When the engine begins to lug down, the hydraulic oil flow is reduced which in turn slows down the tub rotation. With proper calibration, the engine will only lug down to its optimum horsepower RPM and the tub rotation will be varied proportionally to keep the engine at this RPM.

## CALIBRATION

1. With the engine and hydraulic systems at operating temperature, the clutch or PTO engaged, and the handle of the manual hydraulic valve in the forward position. Throttle the engine up to the desired engine RPM, (check engine operation manual for proper RPM).
2. Switch the “Range Switch” to the H or high position. Rotate the “Engine Load Knob” to the minimum (#10) setting. Switch the “Mode Switch” to the ENG.

position. Rotate the “Tub Limit Knob” to the middle setting.

The “Fuse” light and the “Sensor” light should be on. The tub should not be rotating at this time. If the tub is rotating, read the trouble shooting section of the operation manual.

3. Slowly rotate the “Engine Load Knob” counterclockwise until the tub just begins to move. The tub should begin to rotate before you reach the maximum (o) setting. If it does not begin to rotate, switch the range switch to M-Medium or L-Low and repeat as necessary.

This is the proper calibration for an engine operating at the RPM set in step 1.

TEST: Throttle engine down and the tub should stop rotating, return the engine to the above engine RPM and the tub should start to rotate.

If the tub will not rotate read the trouble shooting section of the operation manual.

# ELECTRONIC GOVERNOR OPERATION

## TYPICAL ELECTRONIC GOVERNOR SYSTEM

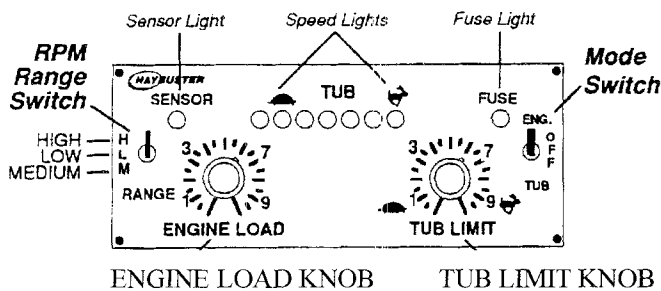
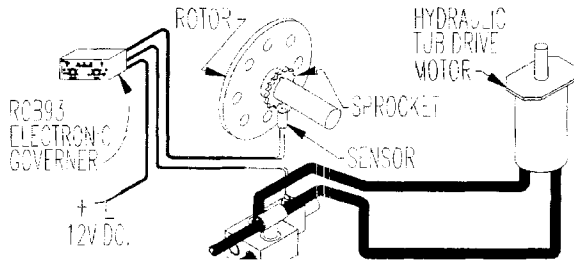

### EXPLANATION OF FRONT PANEL

**“FUSE” LIGHT** - This light is on whenever the electronic governor is receiving power.

**“SENSOR” LIGHT** - This light is on whenever the electronic governor is receiving enough input signal from the sensor. For the sensor light to work you must have the clutch engaged and the engine running at grinding RPM. The “Mode Switch” must be switched to engine.

**“ SPEED” LIGHT** - These lights indicate how fast your tub should be turning based on the output signal that the electronic governor is sending to the electro-hydraulic valve.

### “MODE SWITCH”

**“TUB”** In this position the tub will rotate at a constant speed based on the settings of “Tub Limit Knob”.

**“ENGINE”** - This position uses all the functions of the Electronic Governor. Maximum tub speed will be limited by the “Tub Limit Knob”. Engine load will be controlled by the “Engine Load Knob”.

**“TUB LIMIT”** - This knob sets the maximum speed the tub will rotate in both the “Tub Mode” and “Engine Mode”. In “Engine Mode” Tub speed will vary depending on Engine Load.

**“ENGINE LOAD”** - This knob is used only in “Engine Mode”. It controls the load placed on the engine. Turning the knob clockwise decreases engine load. Turning the knob counterclockwise increases engine load.

**“RANGE” SWITCH** (HI, MEDIUM, & LOW) - This switch is a coarse adjustment for the “Engine Load Knob”

# ELECTRONIC GOVERNOR OPERATION

## TROUBLE SHOOTING ELECTRONIC GOVERNOR SYSTEM

1. When power is reaching the electronic governor the "fuse" light should be on.. If this light fails to go on, check fuse, battery connections, wiring harness, and indicator lamp. If the "Fuse" light is on, the wiring harness, battery connections, fuse and bulb are functioning correctly.

2. "TUB MODE" With the engine and hydraulic systems at operating temperature, and the manual hydraulic valve in the forward position, throttle the engine up to the desired engine RPM.

With the "Mode switch" switched to "Tub", the tub should be rotating. The speed of the tub can be varied by rotating the "Tub Limit Knob" and the number of tub speed lights lit will vary with the setting of the "Tub Limit Knob". The above show you that the manual portion of the controls are functioning correctly. Proceed to step 3. If the manual portion is not working properly, proceed to trouble shooting, chart 2.

### TROUBLE SHOOTING \ CHART 2 \ TUB MODE

<u>PROBLEM</u>	<u>CAUSE</u>	<u>REMEDY</u>
1. Tub does not rotate with pressure to orbit motor (control box and valve working properly).	1. Tub binding 2. Too much material in tub. 3. Tub overloaded due to wet and tough grinding material 4. Pressure relief valve in control valve set too low or faulty.	1. Remove material causing problem. 2. Reduce amount of material in tub. 3. Readjust to 1800 Psi max. 4. Replace relief valve.
2. Tub does not rotate (with 18 (9) to 24 (12) volts DC. power to valve) No pressure to orbit motor.	1. Manual hydraulic valve not engaged. 2. Valve assembly 3. Faulty solenoid	1. Engage valve. 2. Clean or replace valve assembly. 3. Test solenoid and replace as necessary
3. Tub does not rotate (no voltage to valve).	1. No power to control box. 2. Control box switched off. 3. Fuse blown 4. Tub limit knob turned to "O". 5. Broken wire in wiring harness 6. Control box is faulty.	1. Read step 1. 2. Switch mode switch to tub. 3. Replace fuse. 4. Readjust tub limit knob 5. Replace or repair wiring harness. 6. Replace control box.
4. Tub runs with control box switch off. Disconnect wires at valve		
A. If tub stops	1. Control box is out of adjustment. 2. Control box is faulty.	1. Readjust control box. 2. Replace control box.
B. If tub keeps turning	1. Valve override screw is adjusted in too far. 2. Valve is faulty.	1. Readjust override screw. 2. Replace valve.
5. The tub speed can not be varied with tub limit knob	1. Valve override is adjusted in too far. 2. Valve stuck 3. Solenoid stuck. 4. Control box is faulty	1. Readjust override screw. 2. Clean or replace valve assembly. 3. Test solenoid and replace as necessary 4. Replace control box

# ELECTRONIC GOVERNOR OPERATION

## TROUBLE SHOOTING

### ELECTRONIC GOVERNOR

3. "Engine Mode" - After following the "Tub Mode" trouble shooting check list and "Tub Mode" controls function correctly, then follow the calibration instructions. If the tub will not rotate proceed to trouble shooting Chart 3

#### TROUBLE SHOOTING \ CHART 3 \ "ENGINE MODE"

<u>PROBLEM</u>	<u>CAUSE</u>	<u>REMEDY</u>
Tub will not rotate. Sensor light Not lit.	<ol style="list-style-type: none"><li>1. Sensor gap out of adjustment</li><li>2. Broken wire on wiring harness.</li><li>3. Sensor faulty.</li><li>4. Control Box faulty.</li></ol>	<ol style="list-style-type: none"><li>1. Readjust gap to 3/32" (the thickness of a nickel).</li><li>2. Repair or replace wiring harness.</li><li>3. Test and replace sensor as necessary.</li><li>4. Replace control box.</li></ol>
Tub will not rotate. Sensor light lit.	<ol style="list-style-type: none"><li>1. Tub limit knob turned to "O"</li><li>2. Manual hydraulic valve set in neutral.</li><li>3. Control box faulty</li></ol>	<ol style="list-style-type: none"><li>1. Readjust tub limit knob.</li><li>2. Engage manual valve.</li><li>3. Replace control box.</li></ol>

# ELECTRONIC GOVERNOR OPERATION

## ELECTRONIC GOVERNOR HARDWARE TEST.

1. Power source 24 (12) volts DC.  
Current engines are 24 volts, older engines were 12 volts.  
Red wire + positive pin A wiring harness  
Black wire - Negative Pin B wiring harness
2. Test output voltage to valve DC  
Red wire + positive pin D wiring harness.  
Black wire - negative pin E. wiring harness.

### **Tub Mode:**

Test with power supplied to governor control box and mode switch set to "tub". Grinder does not need to be running. Disconnect the wiring harness at the valve, with a voltmeter set for 24 (12) volts DC, connect the red lead of the voltmeter to the red lead of the wiring harness and black lead to the black wire. Turn the "Tub Limit Knob" until the left "Speed" light (turtle) is on. The voltmeter should read approximately 6 (3) volts. Turn the "Tub Limit Knob" clockwise; the voltage should increase and more speed lights light up. Turn the knob until the right speed light (Rabbit) is lit. The voltmeter should read minimum 18 (9) volts.

### **Engine Mode:**

Test with power supplied to governor control box and mode switch set to "engine mode".  
Disconnect the wiring harness from the solenoid valve. Using a voltmeter set to 24 (12) volts DC, connect the red and black leads of the voltmeter to the red and black leads of the harness respectively. Engage clutch and throttle engine to 2100 RPM. Rotate

the engine load fully counterclockwise and the tub limit fully clockwise to maximize load on the engine. At this time the right hand tub speed light should be on, and the voltmeter should be reading 18 (9) volts. Gradually decrease the speed of the engine. As the speed is decreased, the tub speed light should move from right to left. When the left tub speed light is on, the voltmeter should read 6 (3) volts.

3. Output voltage of sensor AC  
Red wire - Pin C wiring harness  
Black wire - Pin B wiring harness.

Set sensor gap to 3/32" (the thickness of a nickel).

Remove wiring harness from the control box.

With the engine at operating temperature and the clutch engaged, throttle the engine up to the desired engine RPM.

With voltmeter set to AC volts connect leads to pins B and C. The voltmeter should read at least 2 to 3 volts AC.

# ELECTRO-HYDRAULIC VALVE OPERATION

## ELECTRO-HYDRAULIC VALVE COIL TEST

This test requires an accurate ohmmeter. Disconnect the wiring harness leads at the valve coil. Set the meter to read ohms ( $\Omega$ ). Place one test lead from the meter on each of the two electrical connections of the valve coil. The reading should be from 8-12 ohms for 12 Volt machines, 39-44 ohms for 24 Volt machines. If the reading is not in this range, replace the coil.

VIEW OF WIRING HARNESS CONNECTOR  
LOOKING DIRECTLY AT CONNECTOR.

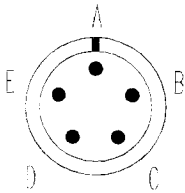

- A - 24 (12) VOLTS DC
- B - GROUND
- C - DIGITAL SENSOR SIGNAL
- D - (+) TO VALVE
- E - (-) TO VALVE

## MANUAL OVERRIDE

NOTE: If there is an electrical failure with your machine you may still be able to grind. Switch the Electronic governor to "OFF". Remove the rubber end cap and loosen the jam nut on the electro-hydraulic valve. Start the machine and engage the tub drive.

**IMPORTANT! - DO NOT ENGAGE CLUTCH AT THIS TIME!**

Turn the adjusting stud clockwise until the tub rotates at the desired speed. Lock the jam nut on the adjusting stud and replace the rubber end cap on the valve coil. The valve will function only as a manual flow control when it is adjusted in this manner. The grinder will now operate as it would if the Electronic Governor were switched to the "Tub mode". There will be No automatic tub control.

Contact your dealer for repairs or replacement parts. When the problems are corrected, readjust Electro-Hydraulic valve.

WIRING HARNESS CONNECTIONS

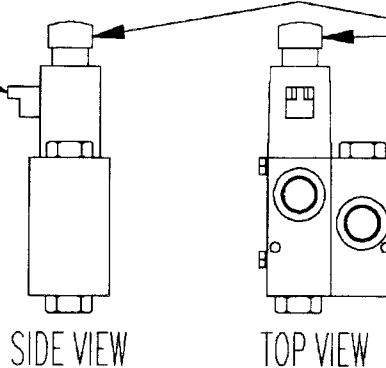

RUBBER END CAP  
JAM NUT AND ADJUSTING  
STUD FOUND UNDERNEATH.



# **TROUBLESHOOTING MICROTRONICS WIRELESS REMOTE CONTROLS.**

## **Manual / Remote Switch**

Check operation of the tub grinder with the manual / remote switch in the “manual” position before troubleshooting the wireless remote control system. If the grinder functions properly in “manual” position and will not function properly in the “remote” position then proceed with troubleshooting of the remote control system. If the grinder will not function in the “manual” position, the problem is not in the wireless remote system.

## **Transmitter Battery**

The transmitter is powered by a 9-volt battery. Replace battery with Heavy-Duty 9-volt battery. Do not use rechargeable ni-cad battery. Remove the battery cover on the lower back of transmitter housing. Plug the 9-volt battery to the battery clip and install inside the chassis. Replace battery cover and you are ready to use the transmitter.

To operate the transmitter, push any switch for desired operation. There is no battery drain on the transmitter when a button is not pushed. If transmitter is not to be used for long periods of time, remove the battery.

## **Receiver**

The receiver is mounted in the control panel enclosure on the left-hand side of the grinder. It is a white metal box with 4 screws on the cover. A manual / remote switch is located on the grinder control panel on the left-hand side of the engine. Power is supplied to the receiver only when this switch is placed in the “remote” position.

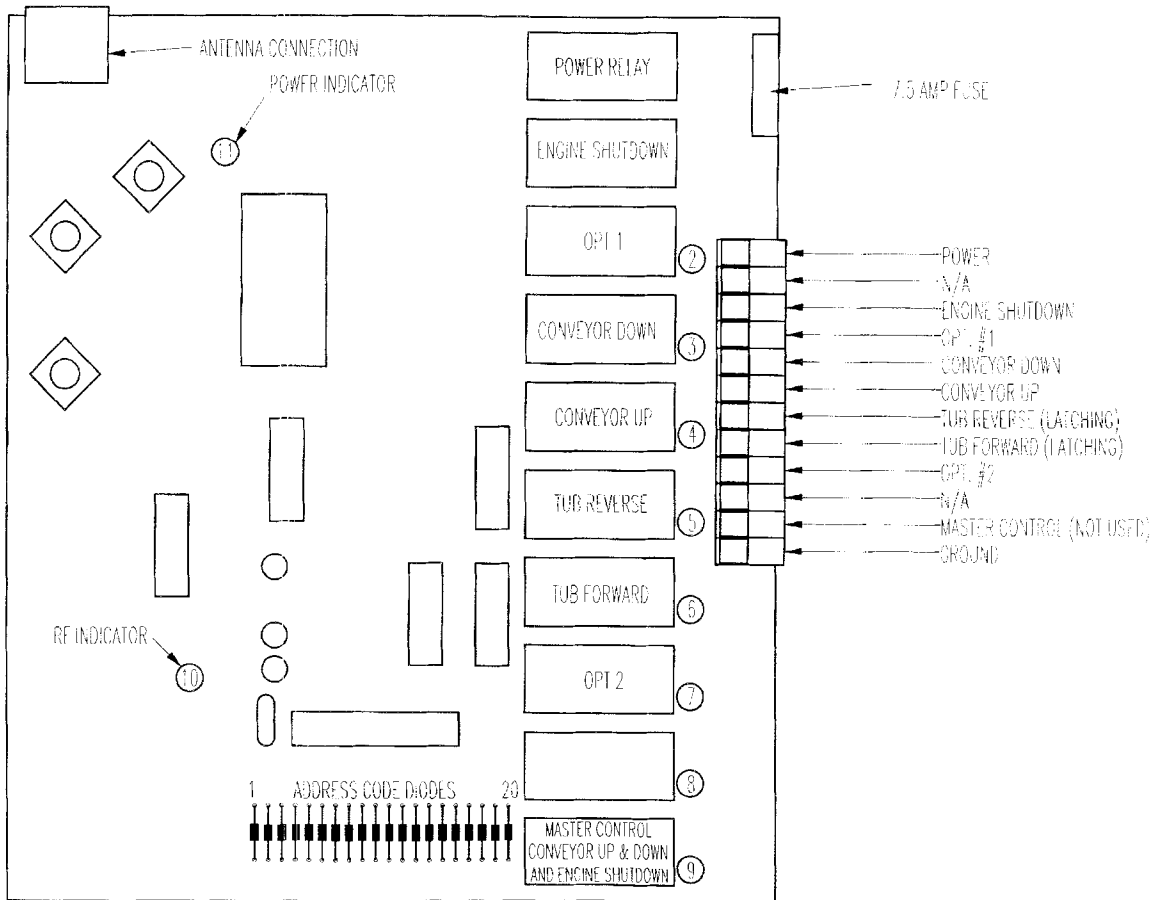

### Receiver Power Check

Remove the cover to the receiver and locate the power indicator lamp (11). Place the manual / remote switch in the “remote” position and turn the engine keyswitch to the “run” position (do not start the engine!). The power indicator lamp (11) should come on. If it does not come on, check the 7.5 amp fuse found in the upper right hand corner of the receiver box. If the fuse is good, check for wiring continuity from the manual / remote switch to the radio receiver. 24 volts DC should be available at the power terminal inside the receiver enclosure.

### Receiver / Transmitter Communication Check

If the power indicator lamp (11) is on, then proceed to test the remote functions. Begin by pressing and holding the ENG button on the transmitter. The RF indicator lamp (10) should come on. When the RF indicator lamp (10) comes on, that is proof that the transmitter is sending a signal and the receiver is receiving the signal. This is true for any of the functions available on the transmitter. If the RF indicator lamp fails to come on, remove the power supply to the receiver and wait for 30 seconds. Connect the power to the receiver and retest. If the RF indicator lamp (10) still does not come on, check the antenna connections and cable.

## Antenna and Cable Check

Disconnect the antenna cable from the receiver. Use an ohmmeter set on the minimum resistance scale and check for continuity of the antenna cable leads. (See the following drawing.) There should be no continuity (maximum resistance reading) between A and B. There should be continuity between A and C (minimum resistance reading). There should be continuity between B and D. The antenna cable at point D should be grounded to the antenna mounting surface. There should be no contact between C and D or between C and "ground".

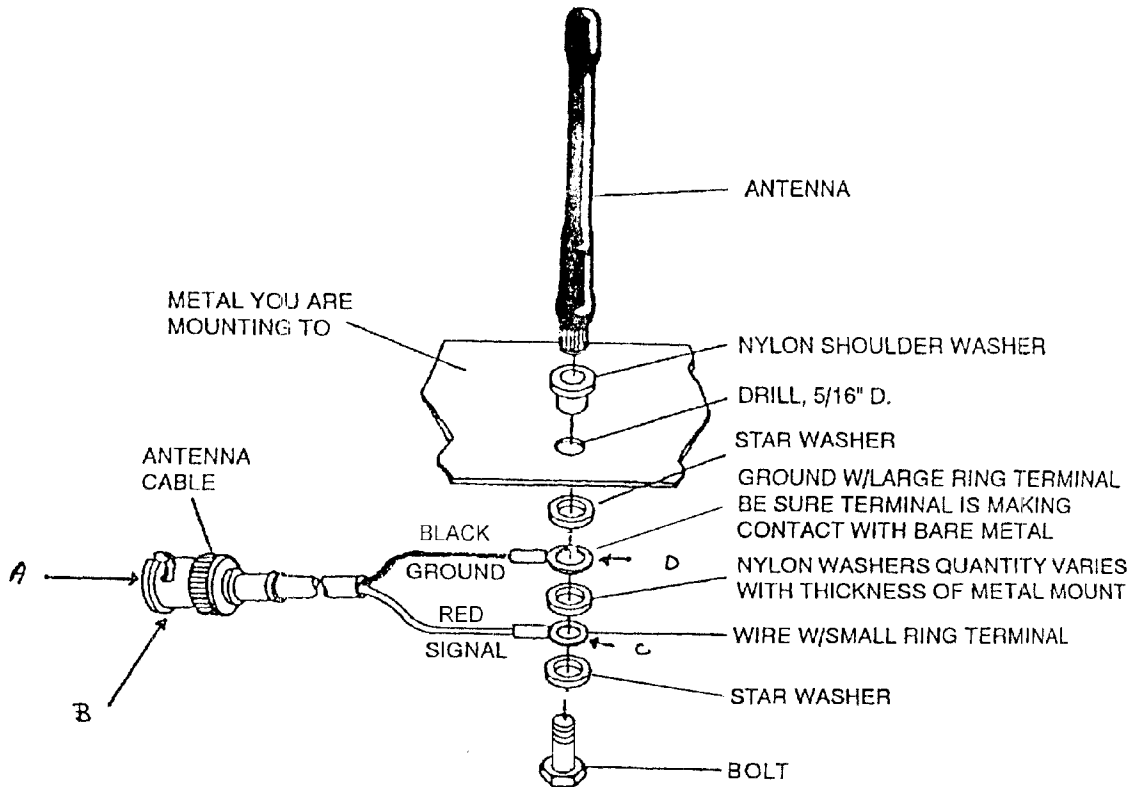

If the transmitter battery is good and the antenna assembly appears to be functioning correctly but a signal is not recognized by the receiver [RF indicator lamp (10) comes on when a signal is recognized], replace the transmitter and receiver or return the transmitter and receiver to DuraTech Industries.

## **Engine Shutdown Check**

Once again press and hold the ENG button on the transmitter. The RF indicator lamp (10) and the master control indicator lamp (9) should come on. Also, the engine shutdown relay will close but there is not an indicator lamp to verify this. Visually observe the contacts in the engine shutdown relay to see that they open and close when you press and release the ENG button on the transmitter. Continuity can be checked by probing the engine shutdown terminal and the ground terminal while pressing and holding the ENG button on the transmitter. If there is continuity when you press the ENG button then this portion of the remote control is functioning properly.

## **Conveyor Up and Down Check**

Press and hold the CONV UP button on the transmitter. The RF indicator lamp (10), the master control indicator lamp (9), and the conveyor up indicator lamp (4) should come on. Press and hold the CONV DOWN button on the transmitter. The RF indicator lamp (10), the master control indicator lamp (9), and the conveyor down indicator lamp (3) should come on. A voltmeter set to read 24 volts DC can be used on the terminal strip to see if voltage is present by probing the conveyor up and conveyor down terminals and the ground terminal while pressing and holding the coinciding button on the transmitter. If either one of these functions is not operating (voltage not present at the terminal) the wire could be transferred to OPT. #1 or OPT. #2 terminal. Use the OPT. #1 or #2 button on the transmitter to operate that function. [ Opt. #1 and Opt. #2 are spare momentary functions.]

## **Tub Forward and Tub Reverse Check**

Press and release the TUB FWD button on the transmitter. The RF indicator lamp (10) and the tub forward indicator lamp (6) should come on. Press and release the TUB FWD button again and the RF indicator lamp (10) and the tub forward indicator lamp (6) should turn off. Press and release the TUB FWD button again and test the terminal strip to see if 24 volts DC is present by probing the tub forward terminal and the ground terminal. Press and release the TUB FWD button again so the indicator lamps turn off and no voltage should be present when probing the tub forward and ground terminals.

Press and release the TUB REV button on the transmitter. The RF indicator lamp (10) and the tub reverse indicator lamp (5) should come on. Press and release the TUB REV button again and the RF indicator lamp (10) and the tub reverse indicator lamp (5) should turn off. Press and release the TUB REV button again and test the terminal strip to see if 24 volts DC is present by probing the tub reverse terminal and the ground terminal. Press and release the TUB REV button again so the indicator lamps turn off and no voltage should be present when probing the tub reverse and ground terminals.

Press and release the TUB FWD button so lamp (6) is on. Press TUB REV once and lamp (6) should go off. Press TUB REV a second time and lamp (5) should come on. Press the TUB FWD button once and lamp (5) should turn off. Press TUB FWD again and lamp (6) should come on.

If all of the output functions appear to be operating correctly the wireless radio remote control is performing as expected. If problems continue, the cause may be in the wiring, connections, or components that the radio control operates.

If the problem appears to be in the radio control transmitter or receiver, replace both components or return both components to DuraTech Industries for repairs. Replacement transmitters [C Band – 5700308, D Band - 5700257] can be obtained from DuraTech Industries to replace lost or damaged transmitters. Address codes can be matched to the existing radio receiver by removing the appropriate diodes from the transmitter circuit board to match your previous transmitter. [See the following drawing.]

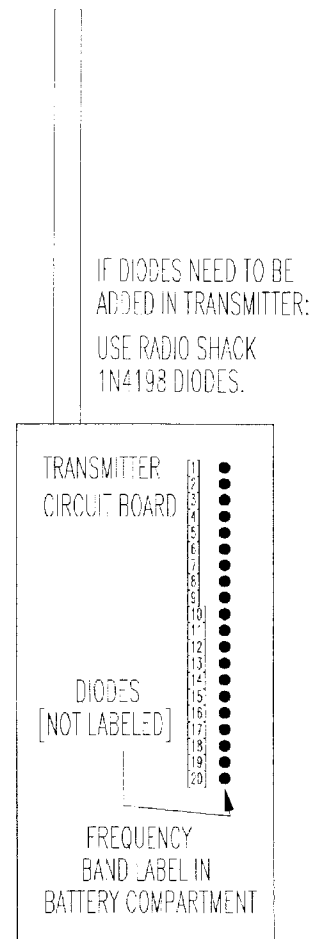
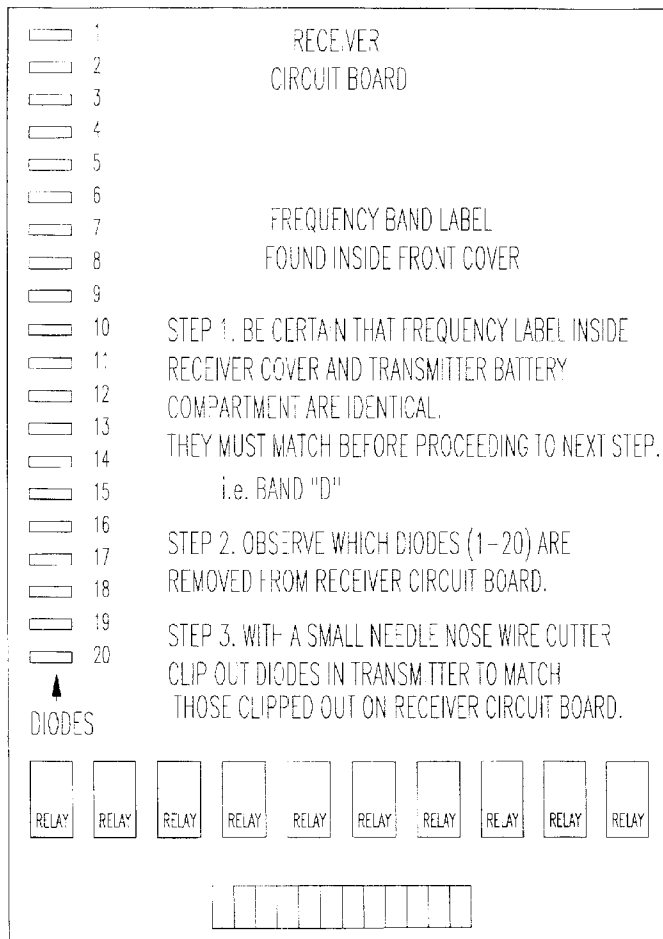

Replacement transmitters and receivers are sold only in matched sets so the address codes match correctly.

24 VDC replacement radio kit part number is 5700224

# LUBRICATION

**CAUTION:** Always follow normal shutdown procedure before adjusting or lubricating.

## HYDRAULIC OIL

Reservoir Capacity - 56 US gallons.

Hydraulic oil filters should be changed after the first 10 hours of operation. Change hydraulic oil and filters after the first 100 hours of operation. Thereafter, change hydraulic oil filters every 500 hours. Change hydraulic oil and filters at least every 1000 hours of operation.

Observe the hydraulic oil frequently. If the oil develops a burnt odor or appearance, a “dirty” appearance, or a “milky” appearance, it should be changed at the earliest possible opportunity. If these conditions occur frequently between scheduled oil and filter changes the maintenance schedule should be altered to a more frequent schedule.

Duratech Industries recommends using Conoco Hydroclear Power Tran Fluid if your machine has a Hydroclear decal on the oil tank. Other acceptable fluids include Mobil 423, Farmland Super HTB, or other similar fluids. If the hydraulic tank does not have this decal, all of the fluids listed above are acceptable.

## BEARING LUBRICATION

Bearings operating in the presence of dust and water should contain as much grease as speed will permit, since a full bearing with a slight leakage is the best protection against entrance of foreign material. In the higher speed ranges, too much grease will cause overheating.

When grinder is operated during cold weather, all lubrication should be performed after bearings are at operating temperatures.

Any bearing operated at high speed and operating at abnormal bearing temperature may indicate faulty lubrication. Normal bearing temperatures may range from “cool to warm to the touch”. Unusually high temperatures “too hot to touch for more than a couple of seconds” accompanied by excessive leakage of grease at the seals, indicates too much grease. High temperatures with no grease showing at the seals, particularly if the bearing seems noisy, usually indicate too little grease. Normal temperature and a slight showing of grease at the seals indicate proper lubrication.

The following chart is a general guide for relubrication. Certain conditions may require more frequent lubrication periods as dictated by experience.

**LUBRICATION CHART**

REF. NO.	LOCATION	NUMBER OF GREASE FITTINGS	FREQUENCY
1.	Tub Drive Shaft Bearings	2	40 hr.
2.	Tub Drive Pivot Points	2	40 hr.
3.	Tub Rollers Bearings	8	40 hr.
4.	Tub Chain Idler	2	Daily
5.	Drive Line	3	40 hr.
6.	Discharge Conveyor Bearings	4	40 hr.
7.	Discharge Conveyor Pivot points	6	40 hr.
8.	Belly Conveyor Bearings	4	40 hr.
9.	Tub Pressure Rollers Bearings	0	Annually
10.	Rotor Bearings	2	Daily
11.	Roller Chains		Oil Daily in Dusty Conditions
12.	Platform hinge	2	40 hr.
13.	Radiator Fan Pulley	1	40 hr.

# LUBRICATION

NOTE: Reference numbers on the following pictures correspond with the lubrication chart.

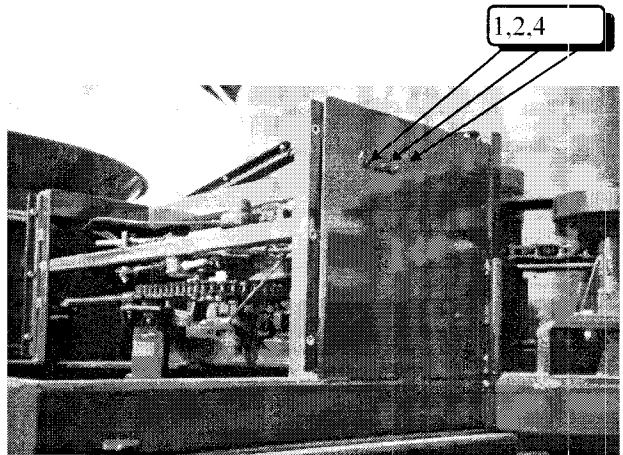
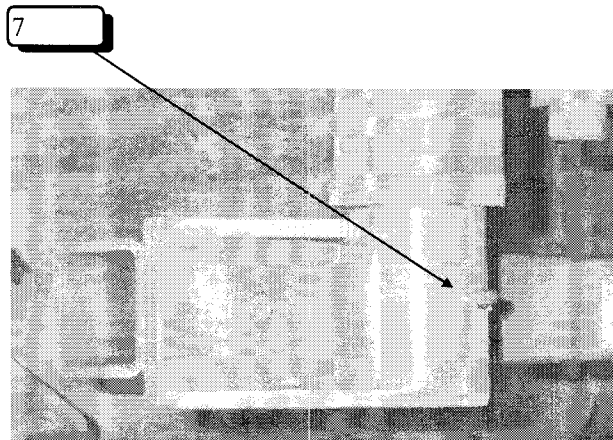
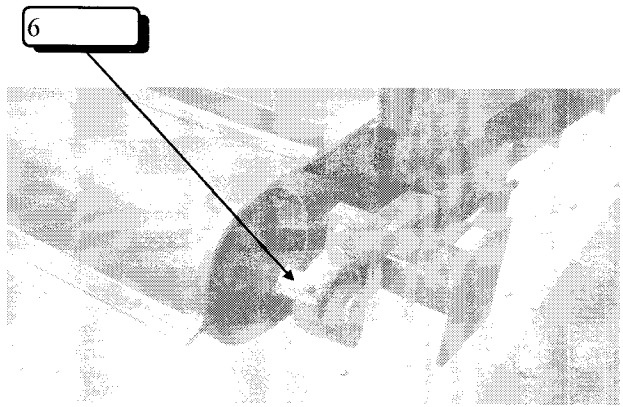
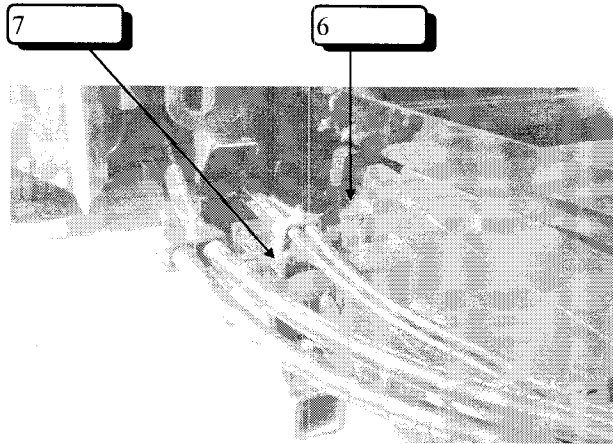
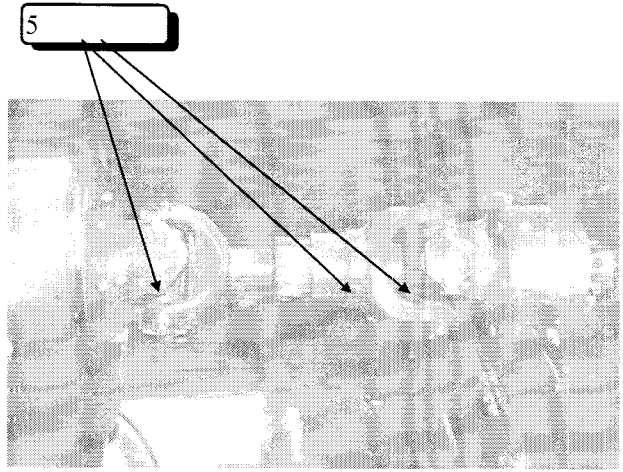
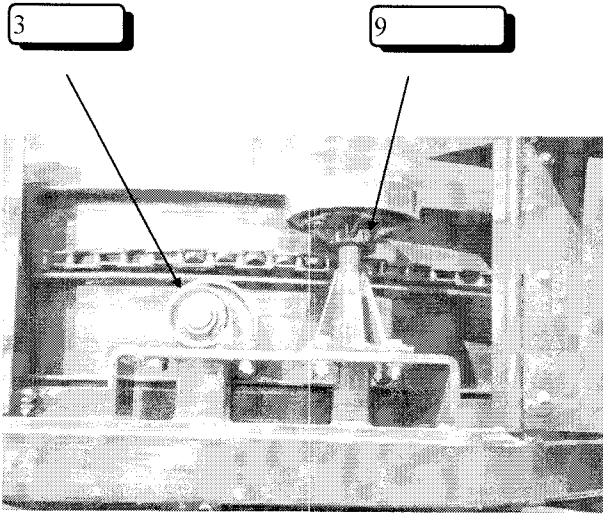

# LUBRICATION

8

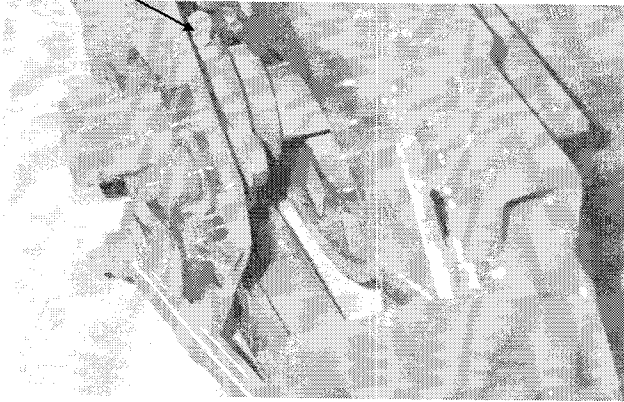

8

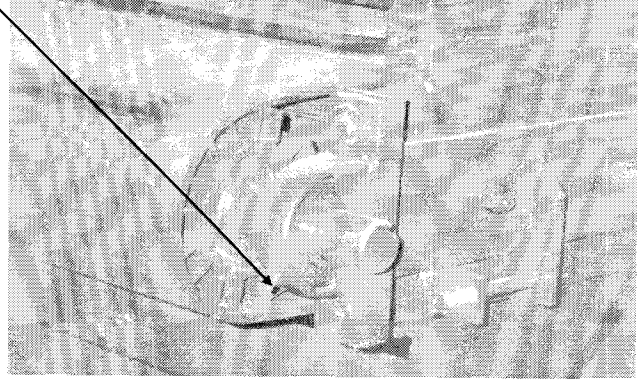

12

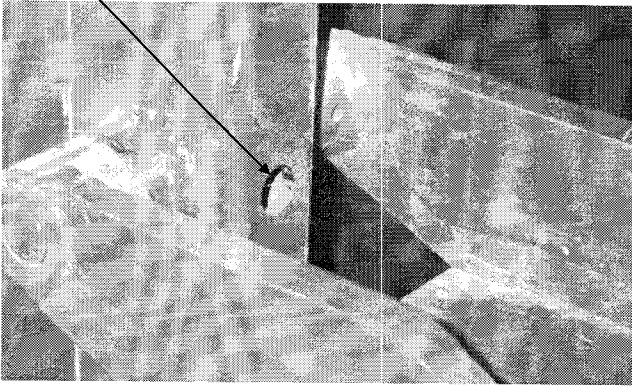

10

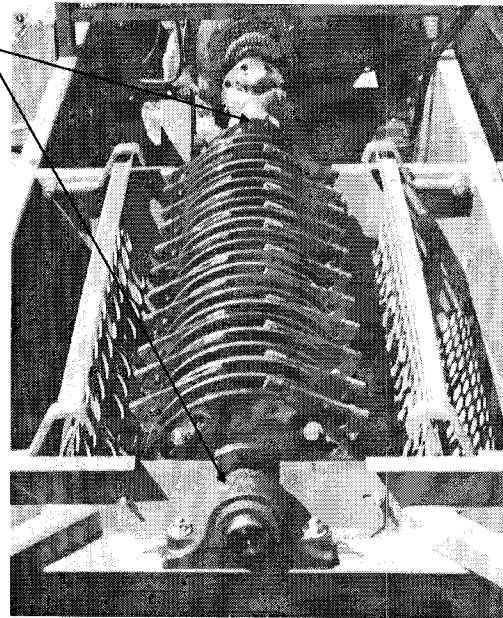

1,2,4

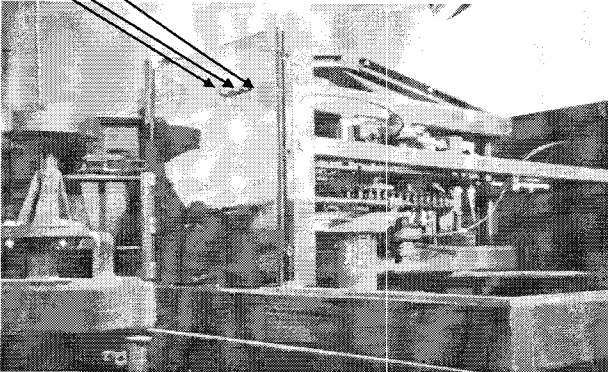

13

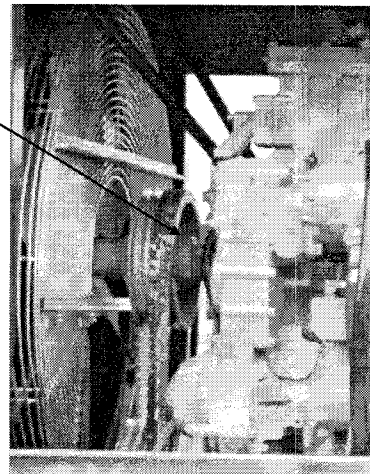



# MAINTENANCE

## **IMPORTANT SAFETY INSTRUCTIONS**

### **READ ALL INSTRUCTION**

**CAUTION: If arc welding is to be done, always ground rotor to frame of machine to prevent arcing in rotor bearings.**

### **SERVICE AND MAINTENANCE**

1. Before working on or near grinder for any reason, including servicing, inspecting or unclogging machine:
2. Disengage rotor clutch.
3. Be certain that parking brakes are set.
4. Shut off grinder engine and remove key. Place a warning lockout tag near the switch to prevent other personnel from inadvertently starting the equipment while service is being performed.
5. Do not begin any service procedures until all machine movement has stopped
6. When replacing any part on your grinder, use only DuraTech Industries authorized parts.
7. Relieve all pressure in the hydraulic system before disconnecting the hydraulic lines or performing other work on the hydraulic system. Make sure all connections are tight and the hoses and lines are in good condition before applying pressure to the system.
8. Hydraulic fluid escaping under pressure can be invisible and have enough force to penetrate the skin. When searching for a suspect leak, use a piece of wood or cardboard rather than your hands. If injured, seek medical attention immediately to prevent serious infection or reaction.
9. Visually examine to see if any internal parts show excessive wear. Repair or replace needed parts. These parts should include rotor plates and holes in the

plates that support the hammer rods. Enlarged holes can cause hammer rods to break. Also check rods, rod locking and retaining devices, hammers, screens, screen tracks and hold downs, main shaft, lid locking devices, hinges or anything else that could wear and perhaps fail if not properly maintained, and cause damage to the rotor and/or personnel. Bearing alignment should also be checked along with mounting bolts to insure a firm foundation and reduced vibration.

10. Keep all foreign objects out of the tub and away from the rotor. Foreign objects may result in personal injury or cause severe damage to hammers, screens, rods, and other parts that may cause rotor failure.
11. Check for loose or worn chains and loose or worn sprockets.
12. Keep sprockets and pulleys aligned.
13. Inspect rotor and all rotating parts for material buildup. Clean as necessary.
14. If machine is going to set for an extended period of time, tub floor should be cleaned and repainted to prevent rust and sticking problems at start up time.
15. The proper tire pressure is 120 psi.
16. The wheel bearing lube level should be checked monthly. Use 80W-90 Hypoid gear oil. Proper level is marked on the transparent hubcap. Change lube annually.
17. Tighten wheel lug nuts to 450-500 Ft.-Lb.

# MAINTENANCE

## HAMMERMILL

Because of the high capacity of the machine, the hammers will wear and must be considered expendable, each hammer has four cutting corners. For maximum life, it is suggested that hammers be rotated periodically to even out the wear over the entire hammer.

The hammers are designed to grind the normal ingredients used in the manufacture of feed and related products. They are not designed to grind or crush, on a primary basis, hard materials such as coal, minerals, metals, rock, or other similar materials, which could cause parts to fail. These materials should never enter a hammermill.

The hammers have been designed and manufactured to provide the best compromise between hardness for good wearing qualities and strength for dependability and resistance to breakage.

**WARNING:** Any alteration of the hammer by heating, grinding, resurfacing or any other process can change the mechanical properties of the hammer and make it unsuitable or dangerous to use.

## HAMMER AND SCREEN CONDITION

Rotor hammers and screens are the heart of the machine. If cutting edges of the hammers become rounded, hammers should be replaced or turned to expose a new cutting edge. Each hammer has four cutting edges. If end of hammer is allowed to wear too long, one cutting edge is lost. Also badly worn hammers weaken area around hole in hammer so it cannot be turned end for end.

Screens have two cutting edges. When hole cutting edges become rounded, screen can be turned end for end exposing new cutting edges.

The results of badly worn hammers and screens are loss of capacity, and added horsepower requirements.

**NOTE:** Hammer and hammer rod life can be extended by keeping rotor rotating at 2000 rpm. Too much horse power and/or over feeding the rotor will cause the hammers to lay back resulting in excessive wear on both hammers and hammer rods!

## HAMMER RODS

Rods can be turned end for end exposing a new surface area for wear. This will extend service life although hammer rods must be considered expendable.

**CAUTION:** Keep all foreign objects out of the tub and away from the rotor. Foreign objects may result in personal injury or damage to the machine.

# MAINTENANCE

## HAMMER REPLACEMENT

When installing or changing hammers, be sure to follow diagram carefully. Misplacement could cause excessive vibration. We recommend that hammers be balanced in sets according to the rod on which they are to be installed. Sets of equal weight should be installed 180 degrees apart (See illustration A.) When replacing a worn or broken hammer with a new hammer always install a second new hammer 180 degrees from the first (See illustration B.)

1. Grind out as much material as possible from the tub. Stop tub rotation.
2. Disengage rotor clutch.
3. Stop discharge conveyors.
4. **After the rotor has stopped completely**, the material remaining in the tub may be dumped by tilting the tub platform. Make certain that all personnel are clear of the area before performing this operation. A bale can roll or tumble a great distance before coming to rest after being dumped from the tub.
5. Make certain the tub platform is fully raised and insert the hydraulic cylinder

block. **Never work on the machine with the tub partially raised**

6. **CAUTION: Shut off engine and remove key. Tag the switch with a warning to prevent other personnel from inadvertently starting the machine while service work is being performed.**
7. Use a bar or chain to hold the rotor stationary. **Do Not use the rotor clutch.**
8. Loosen two bolts at rear of rotor which holds the movable plate in place.
9. Rotate movable plate counter clockwise to align holes allowing hammer rods to be removed through rear of rotor.
10. Remove one row of hammers and replace, taking note as to where any spacers are located.
11. After all hammers have been replaced, reassemble movable plate.
12. When starting the rotor after installing a new set of hammer or turning corners, watch for unusual or excessive vibration. If any occurs, immediately shut off the rotor. Check to see what is wrong and correct it before starting the rotor again.

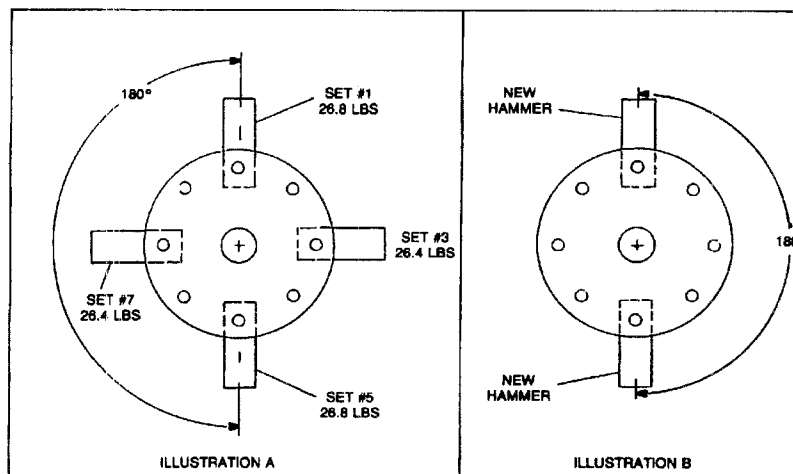

# MAINTENANCE

## CONVEYOR BELTS

Discharge conveyor upper and lower rollers are adjustable to allow for belt stretch. If conveyor belt slows down or stops during operation, tighten adjusting bolts equally to keep belt centered on rollers. Belt tightness should be judged based on slippage

## CONVEYOR BELT ADJUSTMENTS

### I. Safety Considerations.

A. Allow only responsible, properly instructed individuals to operate, service, adjust or maintain this machine. Carefully supervise inexperienced personnel.

B. Do not work on or around equipment with loose clothing, necklaces or neckties, etc. Keep long hair confined.

C. Keep hands, feet and clothing away from power driven parts.

D. Before working on or near grinder for any reason, including adjusting, servicing, inspecting or unclogging machine:

1. Disengage rotor clutch.
2. Shut off grinder engine and remove key.
3. Be certain that parking brakes are set. Shut down tow vehicle and remove key.
4. Do not begin any service procedures until all machine movement has ceased.

### II. Tension Adjustment

Both rollers on the belly conveyor and the discharge conveyor are adjustable to allow for belt stretch and tracking. If the conveyor belt slows down or stops during operation, slippage may be the cause. Tighten adjusting

bolts equally to increase conveyor belt tension and to keep the belt centered on the rollers.

**IMPORTANT: Do not overtighten conveyor belts. Use only enough tension to eliminate belt slippage.**

### III. Tracking Adjustment

**A. When a new belt is installed: (Use only genuine DuraTech Industries parts.)**

Begin by adjusting the **drive** roller so the mounting bearings are the same distance from the end of the conveyor frame (roller centerline is square with conveyor frame). Adjust the **idler** roller tension spring bolts so they are equal on both sides of conveyor.

**B. If the belt is running to the right side:**

1. Adjust the **idler** roller tension spring bolt on the right side of the conveyor. Increase tension by approximately 2 full turns of the adjusting nut.
2. Make certain that all personnel are clear of machine and start engine. Engage hydraulic conveyor drive lever.
3. Observe conveyor belt tracking from a safe location.
4. If further adjustment is required, disengage hydraulic conveyor drive lever and shut down engine.

# MAINTENANCE

5. Some adjustment of the **drive** roller may be required if no improvement is noted by increasing the **idler** roller tension.

6. Repeat steps 1-5 until proper tracking is obtained.

## **C. If the belt is running to the left side:**

1. Adjust the **idler** roller tension spring bolt on the left side of the conveyor. Increase tension by approximately 2 full turns of the adjusting nut.

2. Make certain that all personnel are clear of machine and start engine. Engage hydraulic conveyor drive lever.

3. Observe conveyor belt tracking from a safe location.

4. If further adjustment is required, disengage hydraulic conveyor drive lever and shut down engine.

5. Some adjustment of the **drive** roller may be required if no improvement is noted by increasing the **idler** roller tension.

6. Repeat steps 1-5 until proper tracking is obtained.

## ROTOR BEARING

### **Installation of new bearings:**

Inspect shaft. Insure that the shaft is smooth, straight, clean and within commercial tolerances.

Inspect bearing. Do not allow bearing to be exposed to any dirt or moisture. Do not remove slushing compound as it acts as both a protectant and lubricant and is also compatible with standard greases.

# MAINTENANCE

## TUB CHAIN DRIVE

Tub drive chain is equipped with spring tensioned idlers. Due to normal wear the tub drive chain may tend to climb on driving teeth of tub. If this should occur, the chain should be sized to fit the tub, and the tub teeth adjusted for proper spacing in the chain.

**Step 1.** (sizing the chain). Remove tub drive chain from the drive sprocket. Loosen tub teeth and wrap the chain around tub. (Do not run the chain around tightener idlers or drive sprocket.) Using  $\frac{1}{2}$ " bolt inserted through the chain links, draw chain together so center to center measurement on link pins matches pins on connector link. If the distance is less or greater than the connector link, shims must be added. Equally space shims of the same thickness and length under chain until proper distance is obtained. Do not add shims under tub teeth. (See illustration.)

**Step 2.** Adjust tub teeth so all four sets of teeth contact chain link on the same side of the teeth. Tighten bolts holding teeth in place and return chain to working position.

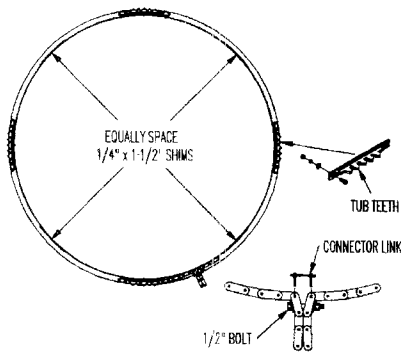

SIZING TUB CHAIN

## ADJUSTING TUB CHAIN TENSION

1. Make sure the Tub Chain is sized to the Tub (see TUB CHAIN DRIVE).
2. Loosen idler A so it does not touch the chain.
3. Tighten idler B to eliminate any sag in the chain. If it can not be tightened sufficiently, shims must be inserted between drive shaft bearing and frame. Add shims until idler B can be adjusted properly.
4. Tighten idler A to match the idler B. This will keep uniform tension on the tub chain when it is running either direction.
5. Check orbit motor chains, they may need tightening, especially if shims were used.

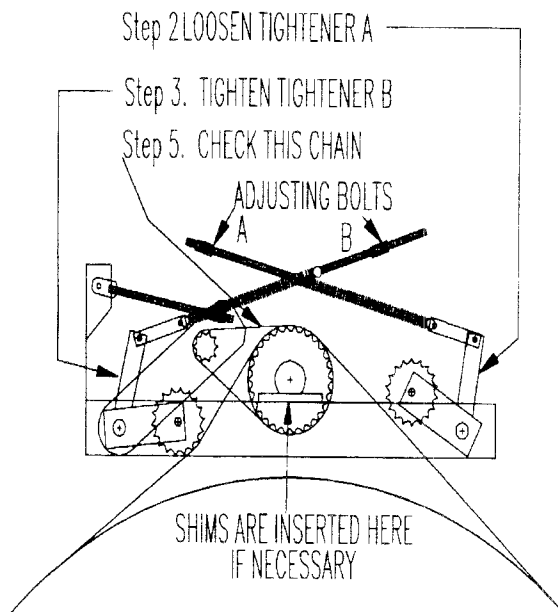

ADJUSTING TUB CHAIN TENSION

# TROUBLE SHOOTING

PROBLEM	CAUSE	REMEDY
1. No grinding capacity	<ol style="list-style-type: none"> <li>1. Screen plugged</li> <li>2. Badly worn screens and/or hammers</li> <li>3. Materials too light or fluffy</li> </ol>	<ol style="list-style-type: none"> <li>1. Clean holes in screen</li> <li>2. Replace or turn worn parts</li> <li>3. Mix with heavier material</li> <li>3a. Use larger screen</li> <li>3b. Clean out with dry bale.</li> </ol>
2. Tub slows down or turns slowly	<ol style="list-style-type: none"> <li>1. Governor not adjusted properly</li> <li>2. Electronic governor system problems.</li> <li>3. Low hydraulic pressure.</li> </ol>	<ol style="list-style-type: none"> <li>1. See <b>Electronic Governor adjustment</b></li> <li>2. See <b>Electronic Governor troubleshooting.</b></li> <li>3. Rebuild or replace hydraulic components as necessary.</li> </ol>
3. Excessive vibration	<ol style="list-style-type: none"> <li>1. Broken hammer</li> <li>2. Defective cylinder bearing</li> <li>3. Misaligned or worn driveline</li> <li>4. Foreign material wrapped in cylinder</li> <li>5. Incorrect hammer pattern</li> </ol>	<ol style="list-style-type: none"> <li>1. See <b>Hammer replacement</b></li> <li>2. Replace bearing</li> <li>3. Replace worn part or complete driveline</li> <li>4. Remove material</li> <li>5. See <b>Hammer replacement</b></li> </ol>
4. Engine loses excessive RPM's before tub stops	<ol style="list-style-type: none"> <li>1. Governor not adjusted properly</li> </ol>	<ol style="list-style-type: none"> <li>1. See <b>Governor Adjustments</b></li> </ol>
5. If tub runs with control box switch off. Disconnect wires at valve.		
A. If tub stops	<ol style="list-style-type: none"> <li>1. Control box is out of adjustment</li> <li>2. Control box is faulty</li> </ol>	<ol style="list-style-type: none"> <li>1. See Electronic governor adjustments.</li> <li>2. Replace control box</li> </ol>
B. If tub keeps turning	<ol style="list-style-type: none"> <li>1. Valve override screw is adjusted in too far.</li> <li>2. Valve is faulty</li> </ol>	<ol style="list-style-type: none"> <li>1. Readjust override screw. See Electronic governor adjustments.</li> <li>2. Replace valve</li> </ol>
6. If tub stalls	<ol style="list-style-type: none"> <li>1. Tub hydraulic system, pressure relief valve set too low.</li> <li>2. Tub overloaded due to wet, tough grinding material</li> <li>3. Too much material in tub</li> <li>4. Tub binding</li> <li>5. Hydraulic oil too hot causing electronic governor valve to bind.</li> </ol>	<ol style="list-style-type: none"> <li>1. Readjust to 2,000 PSI max.</li> <li>2. Reduce amount of material in tub</li> <li>3. Reduce amount of material in tub</li> <li>4. Remove material buildup between tub and platform framework.</li> <li>5. Reduce load on hyd. system or stop and allow oil to cool.</li> </ol>
7. If oil overheats	<ol style="list-style-type: none"> <li>1. Pressure relief valve in control valve set too low</li> <li>2. Tub overloaded</li> <li>3. Worn pump, control valve, hyd. motors, etc.</li> </ol>	<ol style="list-style-type: none"> <li>1. Readjust to 2,000 Psi max.</li> <li>2. Reduce amount of material in tub</li> <li>3. Rebuild or replace hyd. components as necessary</li> </ol>

# HAMMER SPACING

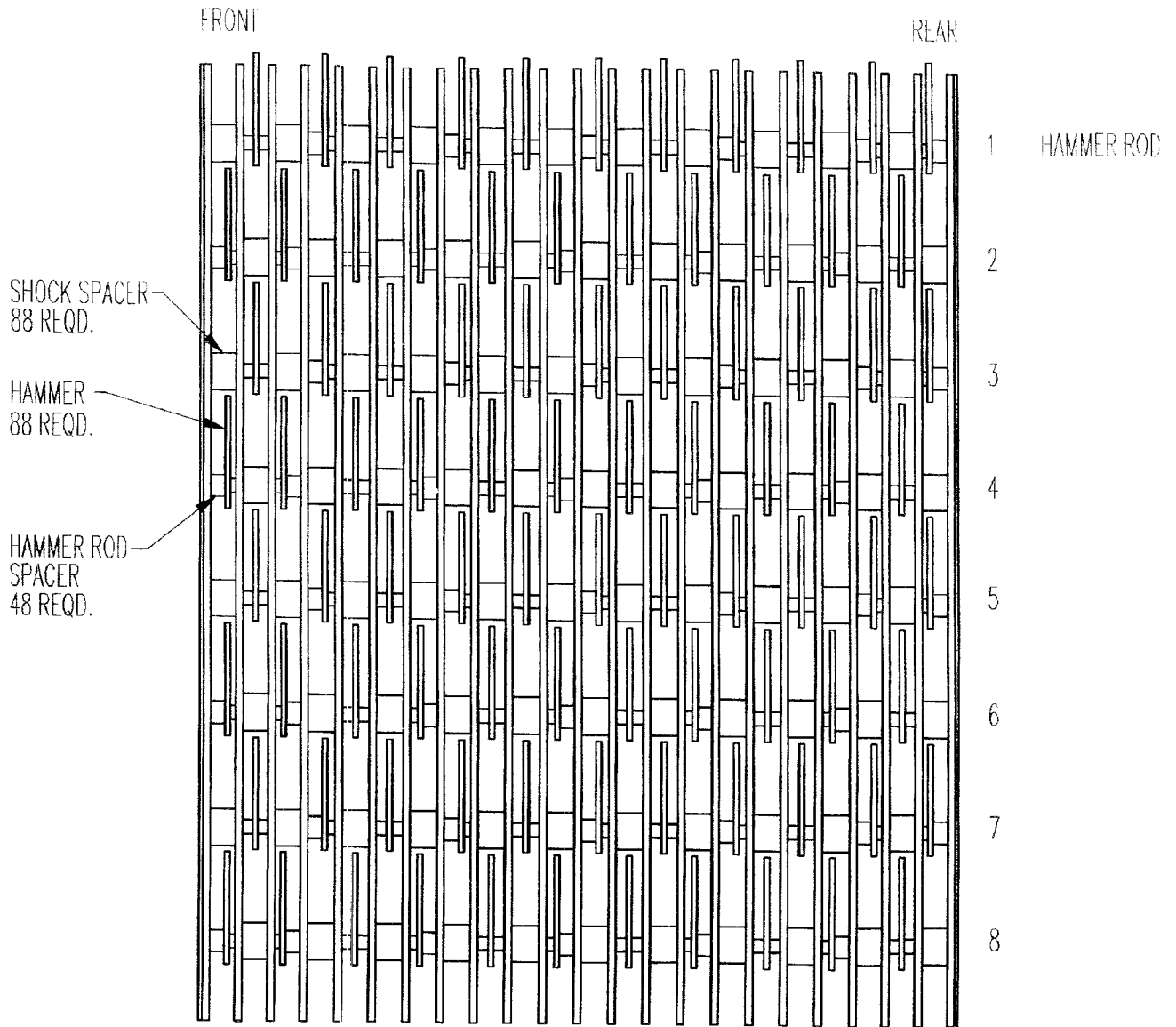



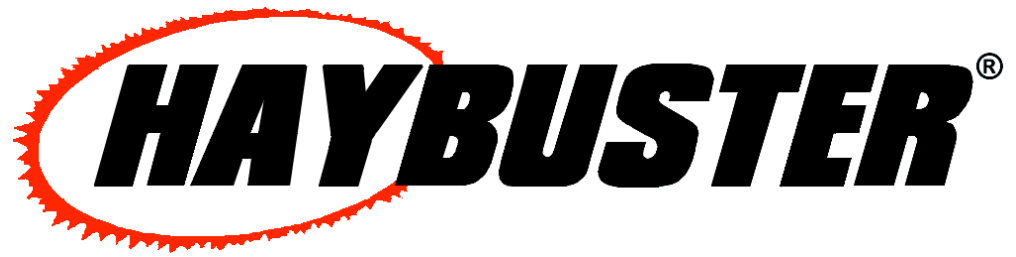

**H-1100E<sup>TM</sup>**

**Tub Grinder**

**Serial Number G10140 & Up**

**Part 2:**

**Parts Reference**

**PARTS REFERENCE TABLE OF CONTENTS**

**Part 2: Parts Reference ..... 41**

HYDRAULIC ASSEMBLY ..... 44

CONVEYOR VALVE - LIFT & FOLD ASSEMBLY ..... 46

REMOTE RADIO OPTION ..... 47

TUB DRIVE VALVE ASSEMBLY ..... 48

TUB DRIVE VALVE ASSEMBLY - REMOTE RADIO OPTION ..... 49

CONVEYOR RUN VALVE ASSEMBLY ..... 50

CONVEYOR LIFT VALVE ASSEMBLY ..... 51

OIL COOLER ASSEMBLY ..... 52

OIL TANK ASSEMBLY ..... 54

HYDRAULIC TANDEM PUMP\20-15\ASSEMBLY ..... 56

HYDRAULIC MOTOR\8\ASSEMBLY ..... 57

GRINDER FRAME ASSEMBLY FOR SN GI0140 - GI0154 ..... 58

GRINDER FRAME ASSEMBLY FOR SN HI0155 AND UP ..... 60

PLATFORM ASSEMBLY - SN GI0140 - HI0184 ..... 62

PLATFORM ASSEMBLY - SN II00185 AND UP ..... 64

TUB DRIVE ASSEMBLY ..... 66

TANDEM AXLE ASSEMBLY ..... 68

ROTOR ASSEMBLY - SN GI0140 - HI0184 ..... 70

ROTOR ASSEMBLY - SN II0185 AND UP ..... 72

CONTROL PANEL ASSEMBLY FOR SN GI0140 - HI0184 ..... 74

CONTROL PANEL ASSEMBLY FOR SN HI0165 AND UP ..... 75

CLUTCH LINKAGE FOR SN HI0165 AND UP ..... 76

GOVERNOR ASSEMBLY ..... 77

BELLY CONVEYOR ASSEMBLY ..... 78

LOWER DISCHARGE CONVEYOR - 26 FT. FOR SN GI0140 TO HI0184 ..... 80

LOWER DISCHARGE CONVEYOR - 26 FT. FOR SN HI0185 AND UP ..... 82

UPPER DISCHARGE CONVEYOR - 26 FT. .... 84

TUB ASSEMBLY ..... 86

ELECTRICAL ASSEMBLY ..... 88

SCHEMATIC - MURPHY CONTROL PANEL - CAT ENGINE 24 VOLT  
ENGINE, 12 VOLT CONTROLS ..... 90

SCHEMATIC - MURPHY CONTROL PANEL - CAT ENGINE 24 VOLT  
ENGINE AND CONTROLS ..... 91

SCHEMATIC - MURPHY CONTROL PANEL - CAT ENGINE 24 VOLT  
SYSTEM WITH STARTER RELAY ..... 92

MURPHY PANEL GAUGES ..... 93

STANDARD WIRING SCHEMATIC- MACHINE & STANDARD WIRING  
SCHEMATIC MACHINE + LIGHT OPTION ..... 94

## PARTS REFERENCE TABLE OF CONTENTS

TUB ROLLER ASSEMBLY .....	96
PRESSURE ROLLER ASSEMBLY .....	97
ORBIT MOTOR PARTS .....	98
HYDRAULIC ELECTRIC SOLENOID PARTS .....	99
GREASELINE LUBE ASSEMBLY .....	100
HYDRAULIC CYLINDER PARTS .....	101
HYDRAULIC VALVE 4000095 (O-RING).....	102
HYDRAULIC VALVE 4000093 PARTS .....	103
HYDRAULIC VALVE 4000096 .....	104
HYDRAULIC VALVE 4000102 PARTS .....	105
HUB 2500453 PARTS .....	106
H-1100E DECALS .....	108
OPTION: ENGINE 3306 CAT .....	112
OPTION: ENGINE 3406 CAT .....	114
OPTION: ENGINE CUMMINS N-14 .....	116
OPTION: GRAIN HOPPER .....	118
OPTION: EAR CORN KIT .....	119
OPTION: MILL COVER .....	120
OPTION: LOOSE HAY GUIDE .....	121
OPTION: CONVEYOR DISCHARGE GUIDE .....	122
OPTION: MILL GRATE .....	123
OPTION: 12 VOLT WORK LIGHTS .....	124
OPTION: 24 VOLT WORK LIGHTS .....	125
OPTION: MAGNETIC ROLLER KIT\18\COMPLETE .....	126
OPTION: AIR COMPRESSOR KIT .....	128
OPTION: RADIO REMOTE .....	130
<b>H-1100E TUB GRINDER DOCUMENTATION COMMENT FORM .</b>	<b>133</b>

# HYDRAULIC ASSEMBLY

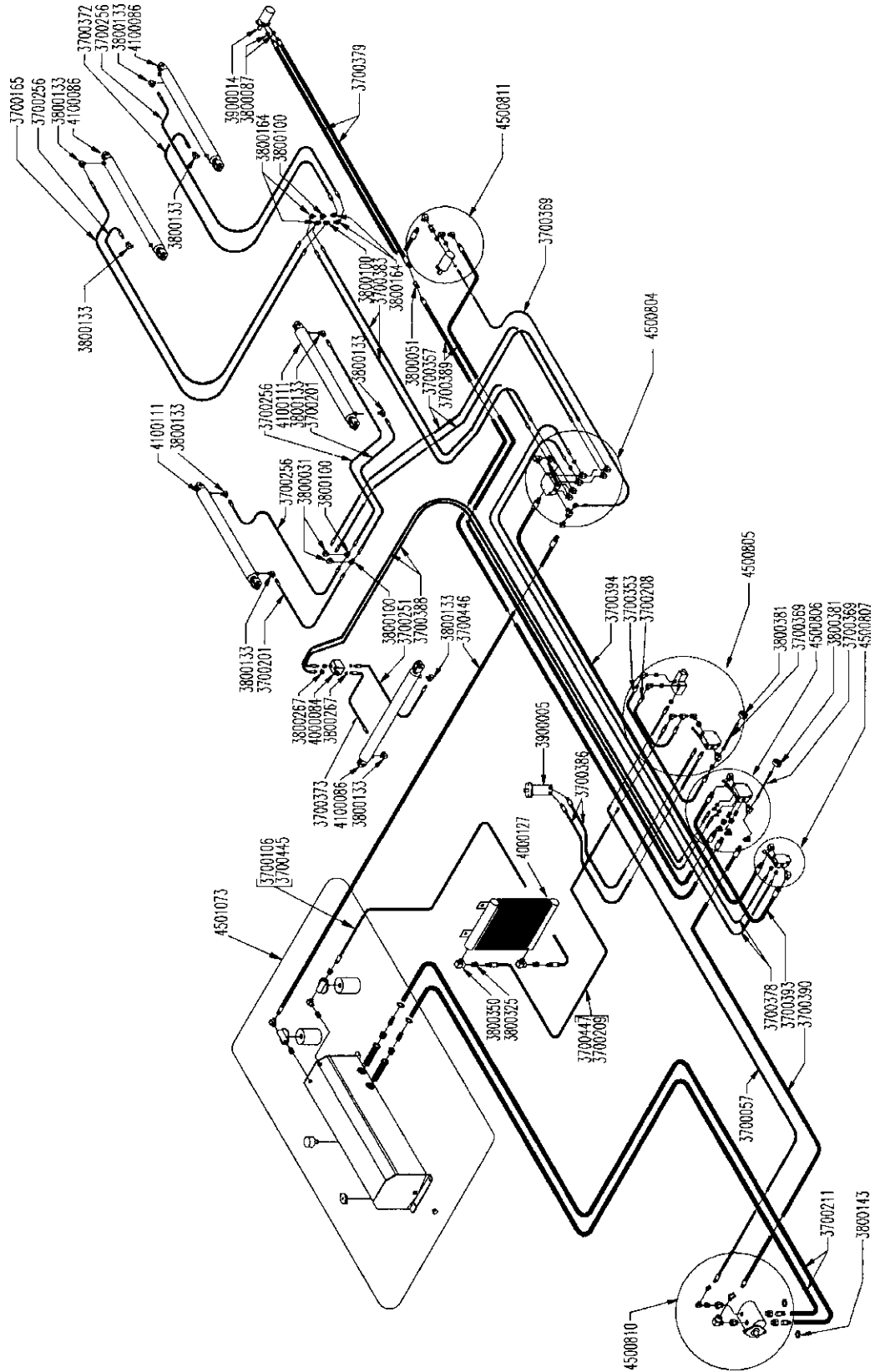

## HYDRAULIC ASSEMBLY

PART	QTY.	PART DESCRIPTION
3700057	1	HOSE\HYD\1\2X58\SW-SW
3700106	1	HOSE\HYD\1\2X122\SW-SW For Cat Engines
3700165	1	HOSE\HYD\3\8X80
3700201	2	HOSE\HYD\3\8X19\SW-SW
3700208	1	HOSE\HYD\1\2X18\SW-SW
3700209	1	HOSE\HYD\1\2X190\SW-SW For Cummins Engines
3700211	1	HOSE\SCTN\1X87
3700251	1	HOSE\HYD\3\8X70\SW-SW
3700256	4	HOSE\HYD\3\8X58\SW-SW
3700353	1	HOSE\HYD\1\2X29\SW-SW
3700357	2	HOSE\HYD\3\8X51\SW-SW
3700369	3	HOSE\HYD\1\4X19\SW-SW
3700372	1	HOSE\HYD\3\8X40\SW-SW
3700373	1	HOSE\HYD\3\8X42\SW-SW
3700378	2	HOSE\HYD\3\8X216\SW-SW0
3700379	2	HOSE\HYD\3\4X282\1\2SW-SW
3700383	2	HOSE\HYD\3\8X98\SW-SW
3700386	2	HOSE\HYD\1\2X156\SW-O-RING
3700388	2	HOSE\HYD\3\8X281\SW-SW
3700389	2	HOSE\HYD\3\4X212\1\2 SWIVEL
3700390	1	HOSE\HYD\3\4X78\SW-SW
3700393	1	HOSE\HYD\3\4X30\SO-SO
3700394	1	HOSE\HYD\3\4X210\SW-SO
3700445	1	HOSE\HYD\1\2X128\SW-SW For Cummins Engines
3700446	1	HOSE\HYD\3\4X226\SW-SW
3700447	1	HOSE\HYD\1\2X183\SW-SW For Cat Engines
3800031	2	FTG\3\8MPX3\8FP\90D\ST;EL
3800051	1	FTG\1\2FP\CPLG
3800087	2	FTG\7\8MORX1\2FP\ADPT
3800100	4	FTG\3\8FP\TEE
3800133	10	FTG\1\2MPX3\8FP\90D\ST;ELL
3800143	2	CLAMP\HOSE\1-1\2\T-BOLT
3800164	4	FTG\3\8MPX3\8FP\45D\ST;ELL
3800267	4	FTG\3\4MORX3\8FP\ADPT
3800325	2	FTG\1MPX1\2FP\BUSH
3800350	2	FTG\1-5\16MORX1FP\90D
3800381	2	GAUGE\3000PSI\REAR STEM
3900005	1	MTR\HYD\14.9\2000\SAE:A see page 96
3900014	1	MTR\HYD\9.6\2000\1-1\4SH see page 96
4000084	1	VALVE\HYD\30GPM\HOLD\DBL
4000089		RAD\HYD\19-3\4X23X2\1FP see page 52
4000127	1	RAD\HYD\19-3\4X23X2\1-5\16FOR see page 52
4100086	3	CYL\HYD\3X30X1-1\2 see page 99
4100111	2	CYL\HYD\3X36X1-1\2\PERP see page 99
4500804	1	VALVE\CNVYR\LFT&FLD\ASSY, see page 46
4500805	1	VALVE\TUB\DRIVE\ASSY\SUB see page 48
4500806	1	VALVE\CNVYR\RUN\ASSY\SUB see page 50
4500807	1	VALVE\CNVYR\LIFT\ASSY\5SUB see page 51
4500810	1	PUMP\HYD\TNDM\20-15\ASSY see page 54
4500811	1	MTR\HYD\8\ASSY\SUB see page 55
4501073	1	TANK\OIL\ASSY\SUB\97 see page 53

**CONVEYOR VALVE - LIFT & FOLD ASSEMBLY**

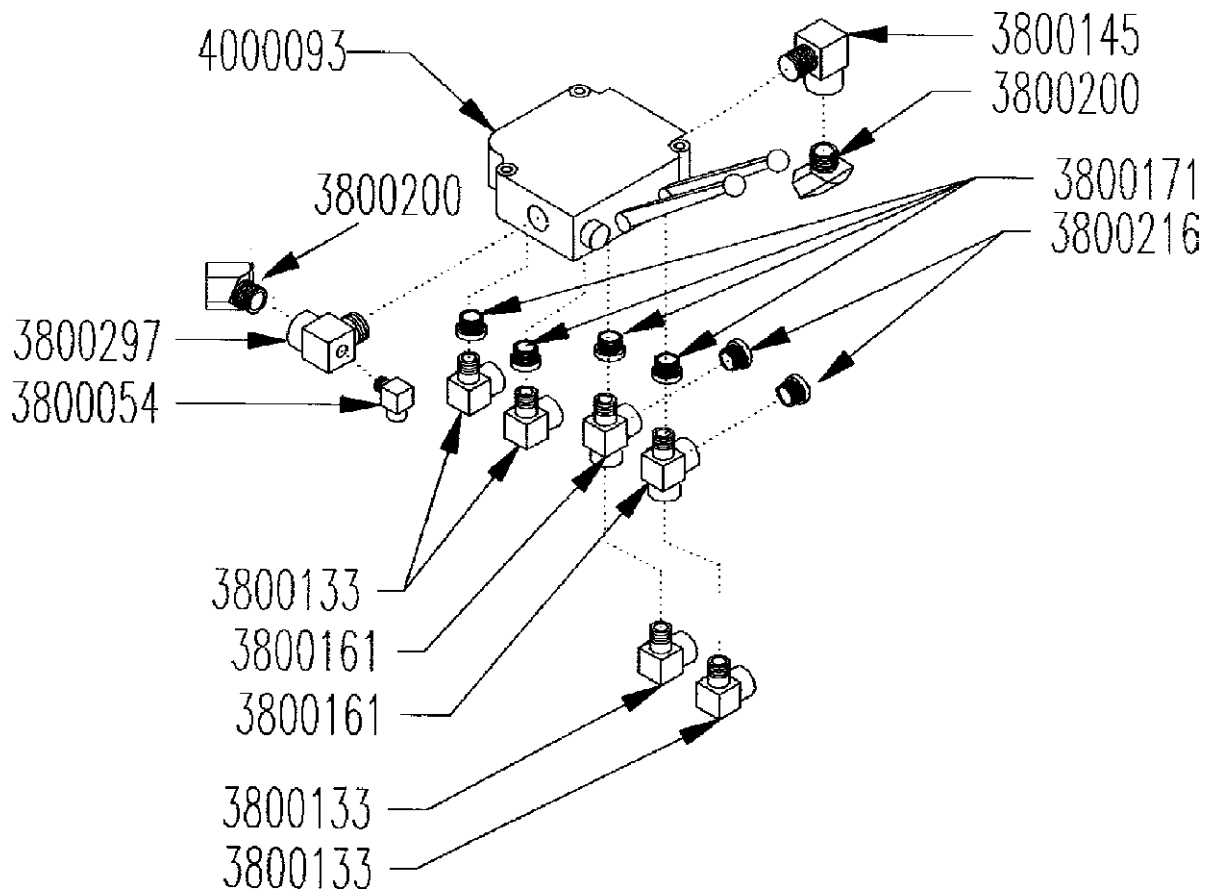

PART	QTY.	PART DESCRIPTION
4500804		VALVE\CONVEYOR\LIFT & FOLD\ASSEMBLY
3800054	1	FTG\1/4MPX1/4FP\90D\ST.ELL
3800133	4	FTG\1/2MPX3/8FP\90D\ST.ELL
3800145	1	FTG\1-1/16MORX3/4FP\90D
3800161	2	FTG\1/2FPX1/2MPX1/2FP
3800171	4	FTG\3/4MORX1/2FP\ADPT
3800200	2	FTG\3/4MPX3/4FP\45D\ST;EL
3800216	2	FTG\1/2MPX3/8FP\BUSH
3800397	1	FTG\1-1/16MORX3/4FP\90D
4000093	1	VALVE\HYD\2-SPL\3POS\4W

**CONVEYOR VALVE - LIFT & FOLD ASSEMBLY  
REMOTE RADIO OPTION**

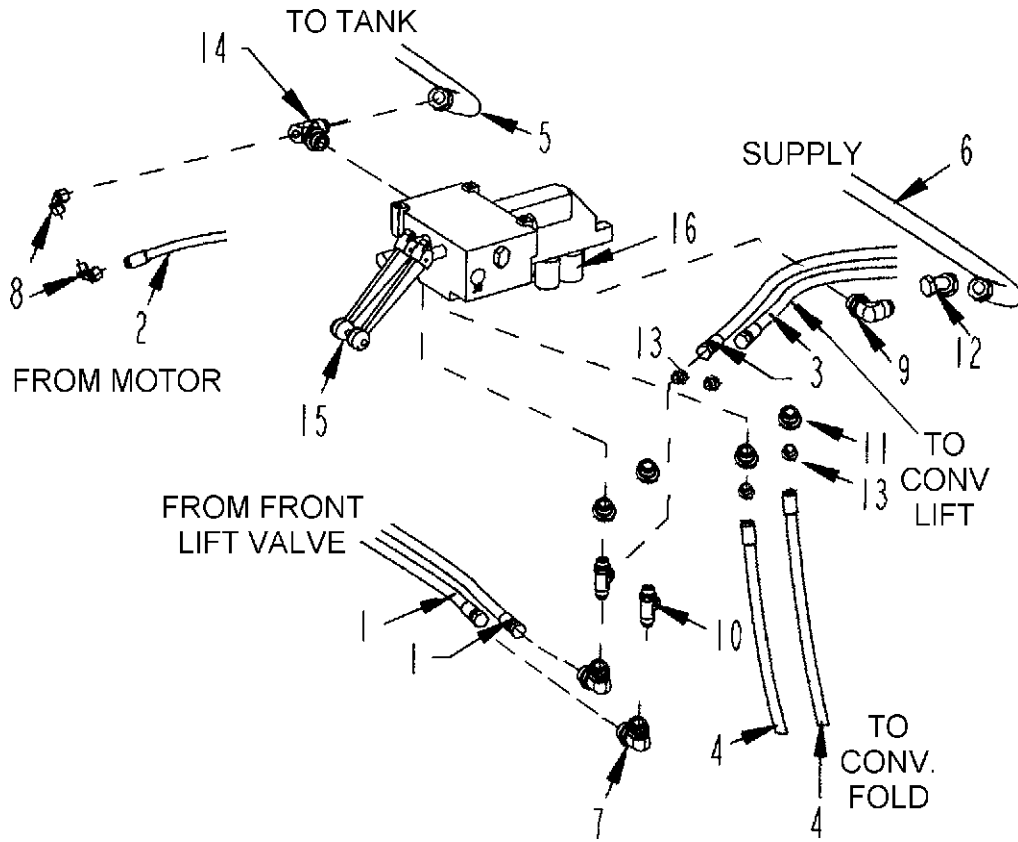

ITEM	PART	QTY.	PART DESCRIPTION
1	3700357	2	HOSE\HYD\3\8X51\SW-SW
2	3700369	1	HOSE\HYD\1\4X19\SW-SW
3	3700378	2	HOSE\HYD\3\8X216\SW-SW
4	3700383	2	HOSE\HYD\3\8X98\SW-SW
5	3700491	1	HOSE\HYD\3\4X236\SW-SW
6	3700492	1	HOSE\HYD\3\4X220\SW-SO
7	3800133	2	FTG\1\2MPX3\8FP\90D\ST;EL
8	3800054	2	FTG\1\4MPX1\4FP\90D\ST;EL
9	3800145	1	FTG\1-1\16MORX3\4FP\90D\ST;ELL
10	3800161	2	FTG\1\2FPX1\2MPX1\2FP\RUN;TEE
11	3800171	4	FTG\3\4MORX1\2FP\ADPT
12	3800200	1	FTG\3\4MPX3\4FP\45D\ST;EL
13	3800216	4	FTG\1\2MPX3\8FP\BUSH
14	3800397	1	FTG\1-1\16MORX3\4FP\90D>ST;ELL\TPPD;1\4FP
15	4000105	1	VALVE\HYD\20GPM\2SPL\24\ 2000PSI\EXPILOT
16	4000117		VALVE\HYD\SOLENOID\24\ FOR 4000105
7	3800031		FTG\3\8MPX3\8FP\90D\ST;EL
11, 13	3800267		FTG\3\4MORX3\8FP\ADPT
10	3800406		FTG\3\8MPX3\8FPX3\8FP\RUN\TEE

**TUB DRIVE VALVE ASSEMBLY**

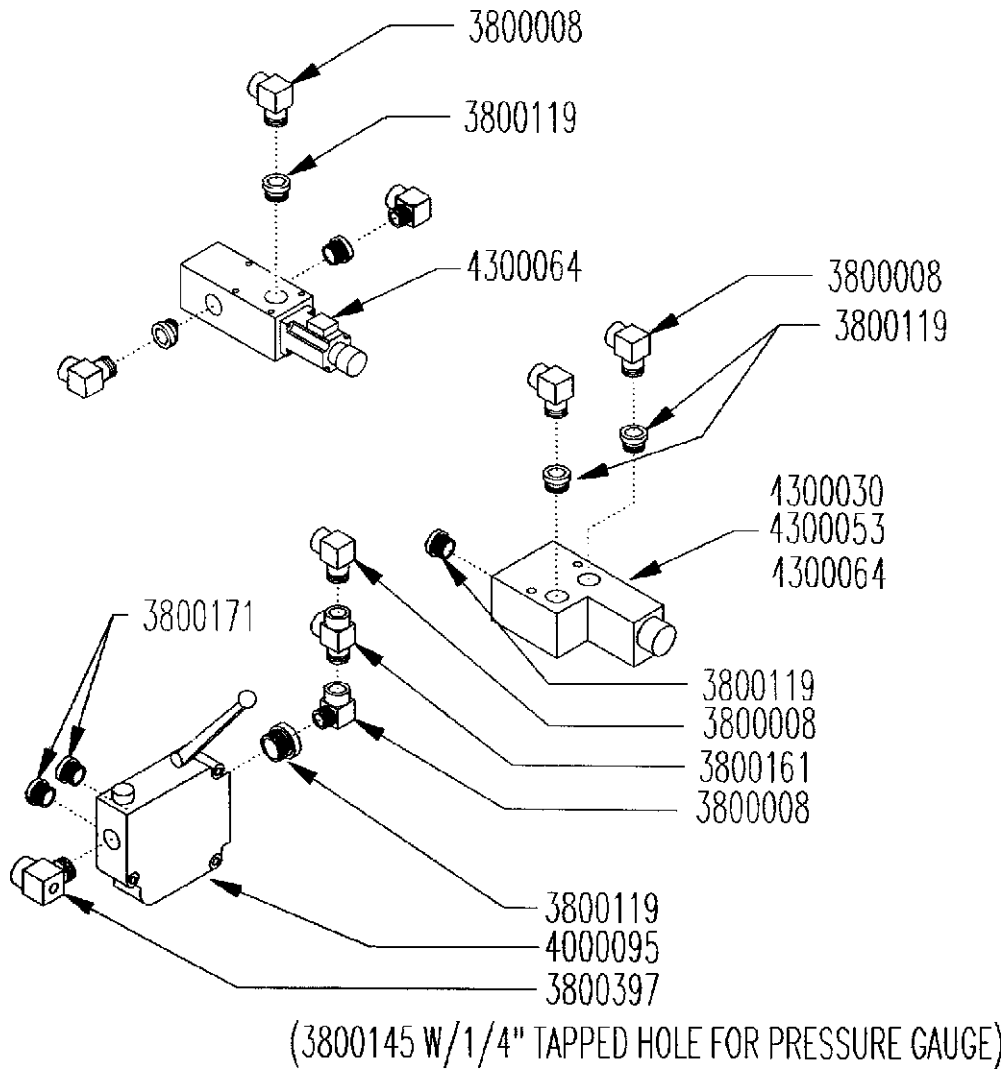

PART	QTY.	PART DESCRIPTION
4500805		VALVE\TUB\DRIVE\ASSY\SUB
3800008	4	FTG\1/2MPX1/2FP\90D\ST:ELL
3800119	4	FTG\1-1/16MORX1/2FP\ADPT
3800161	1	FTG\1/2MPX1/2FPX1/2FP\
3800171	2	FTG\3/4MORX1/2FP\ADPT
3800397	1	FTG\1-1/16MORX3/4FP\90D
4000095	1	VALVE\HYD\1-SPLW\DETENT
4300030		CV93 HYD. ELECTRIC VALVE, 12V see page 97
4300053		CV93 HYD. ELECTRIC VALVE, 24V see page 97
4300064	1	VALVE\SERVO\15GPM\24VDC see page 97
4300065		VALVE\SERVO\15GPM\12VDC see page 97



**TUB DRIVE VALVE ASSEMBLY - REMOTE RADIO OPTION**

PART	QTY.	PART DESCRIPTION
1	3700057	1 HOSE\HYD\1/2X58\SW-SW
2	3700208	1 HOSE\HYD\1/2X18\SW-SW
3	3700353	1 HOSE\HYD\1/2X29\SW-SW
4	3700369	1 HOSE\HYD\1/4X19\SW-SW
5	3700386	2 HOSE\HYD\1/2X156\SW-ORING
6	3700447	1 HOSE\HYD\1/2X183\SW-SW for Cat engines
6	3700209	1 HOSE\HYD\1/2X190\SW-SW for Cummins Engines
7	3800008	4 FTG\1/2MPX1/2FP\90D\ST;EL
8	3800054	1 FTG\1/4MPX1/4FP\90D\ST;EL
9	3800119	4 FTG\1-1/16MORX1/2FP\ADPT
10	3800161	1 FTG\1/2FPX1/2MPX1/2FP\RUN;TEE
11	3800171	2 FTG\3/4MORX1/2FP\ADPT
12	3800381	1 GAUGE\3000PSI\REAR STEM
13	3800397	1 FTG\1-1/16MORX3/4FP\90D\ST;ELL\TPPD;1/4FP
14	4000097	1 VALVE\HYD\20GPM\1SPL\24V
15	4000131	1 VALVE\HYD\SOLENOID\24V FOR 4000097
16	4300064	1 VALVE\SERVO\15GPM\24VDC
	4300054	1 SOLENOID\HYD VALVE\24V
17	3800010	1 FTG\3/4MPX1/2FP\ADPT

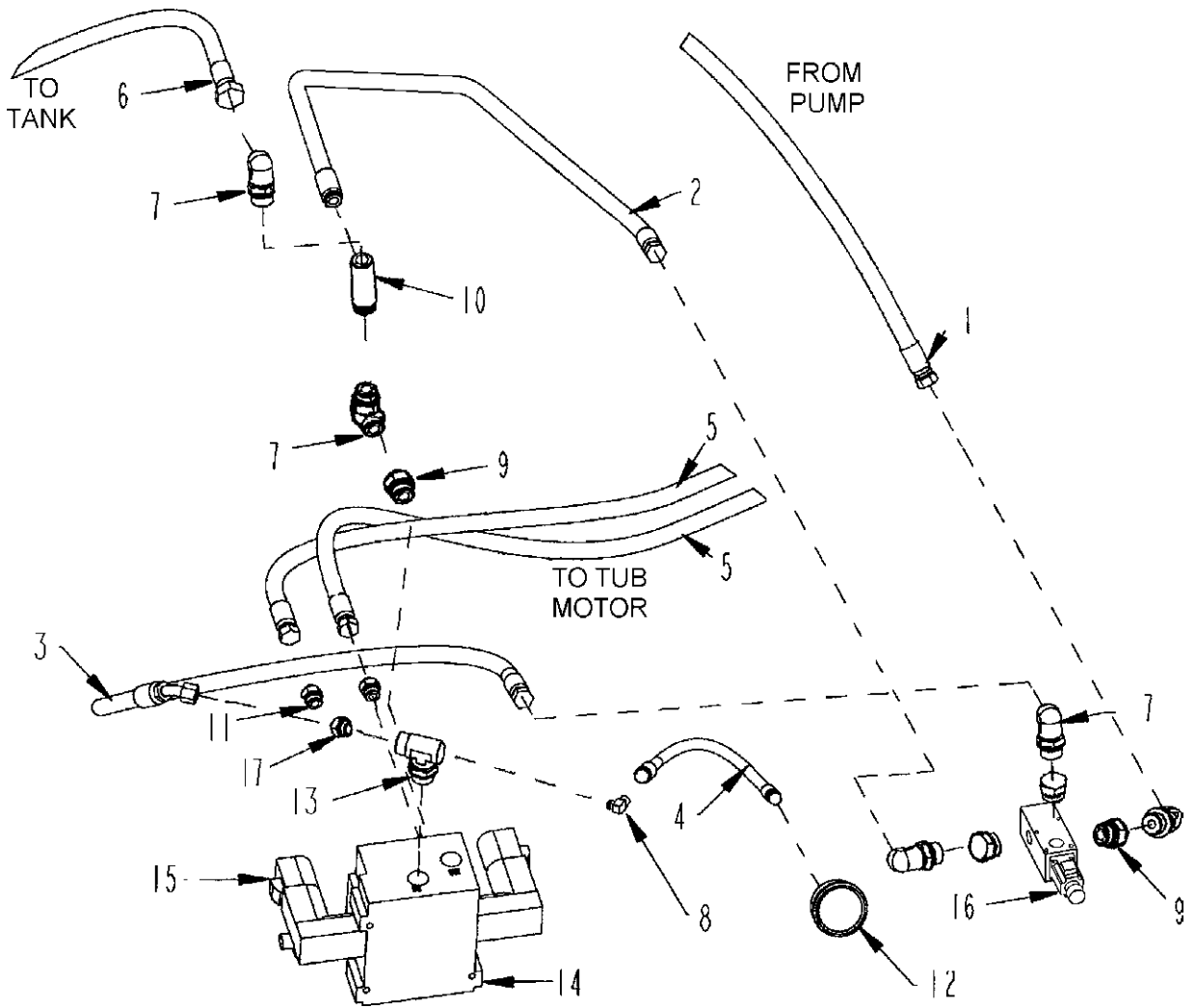

H-1100E TUB GRINDER

PARTS REFERENCE

## CONVEYOR RUN VALVE ASSEMBLY

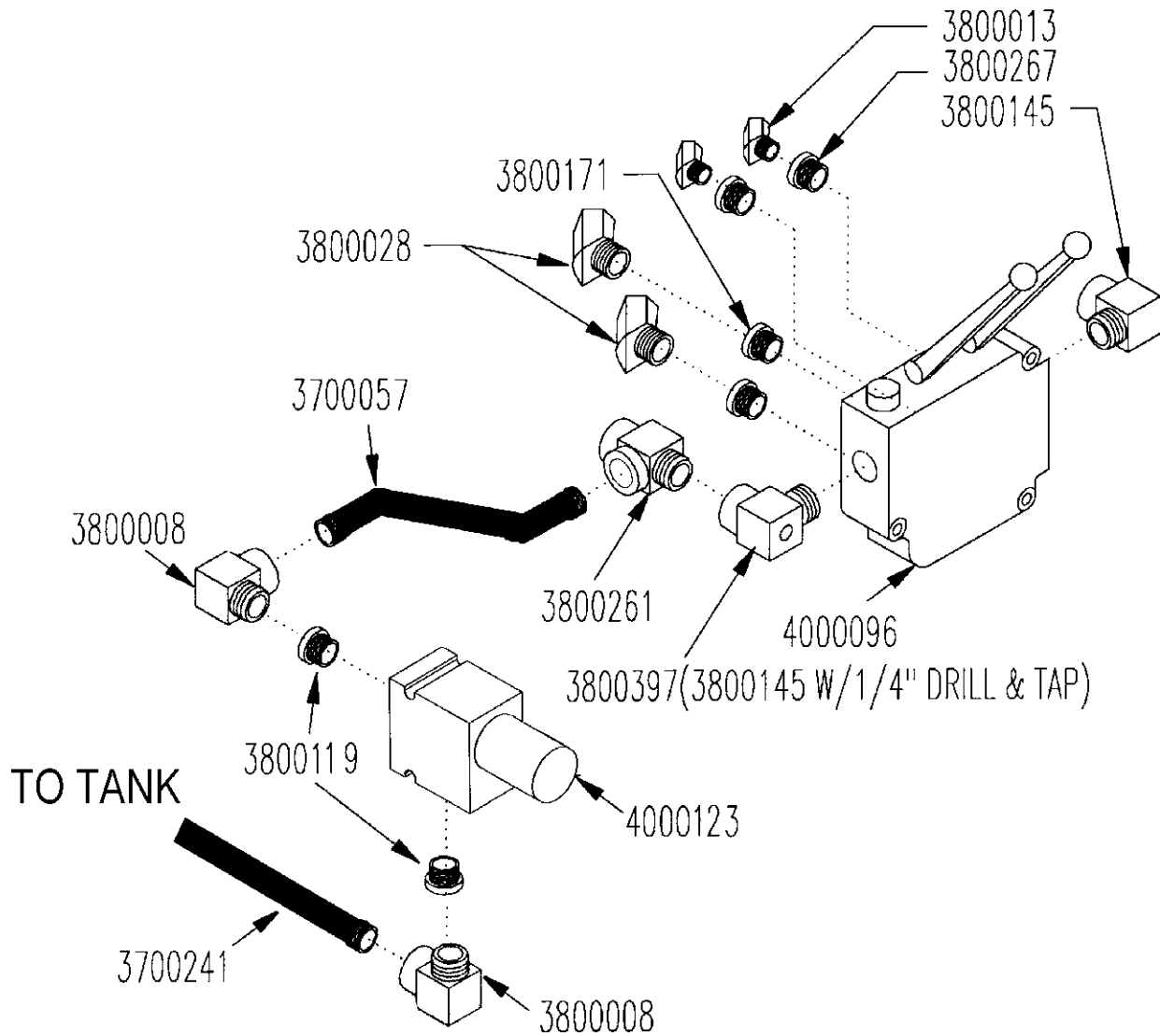

PART	QTY.	PART DESCRIPTION
4500806		VALVE\CNVYR\RUNASSYSUB
3700241		HOSE\HYD\1/2X91
3800013	2	FTG\3/8MPX3/8FP\45D\ST;ELL
3800028	2	FTG\1/2MPX1/2FP\45D\ST;ELL
3800145	1	FTG\1-1/16MORX3/4FP\90DEG
3800171	2	FTG\3/4MORX1/2FP\ADPT
3800267	2	FTG\3/4MORX3/8FP\ADPT
3800397	2	FTG\1-1/16MORX3/4FP\90DEG\W/1/4" TAPPED HOLE
4000096	1	VALVE\HYD\W\DETENT
4000123		VALVE\HYD\RELIEF\2500PSI\1-1/16FOR

## CONVEYOR LIFT VALVE ASSEMBLY

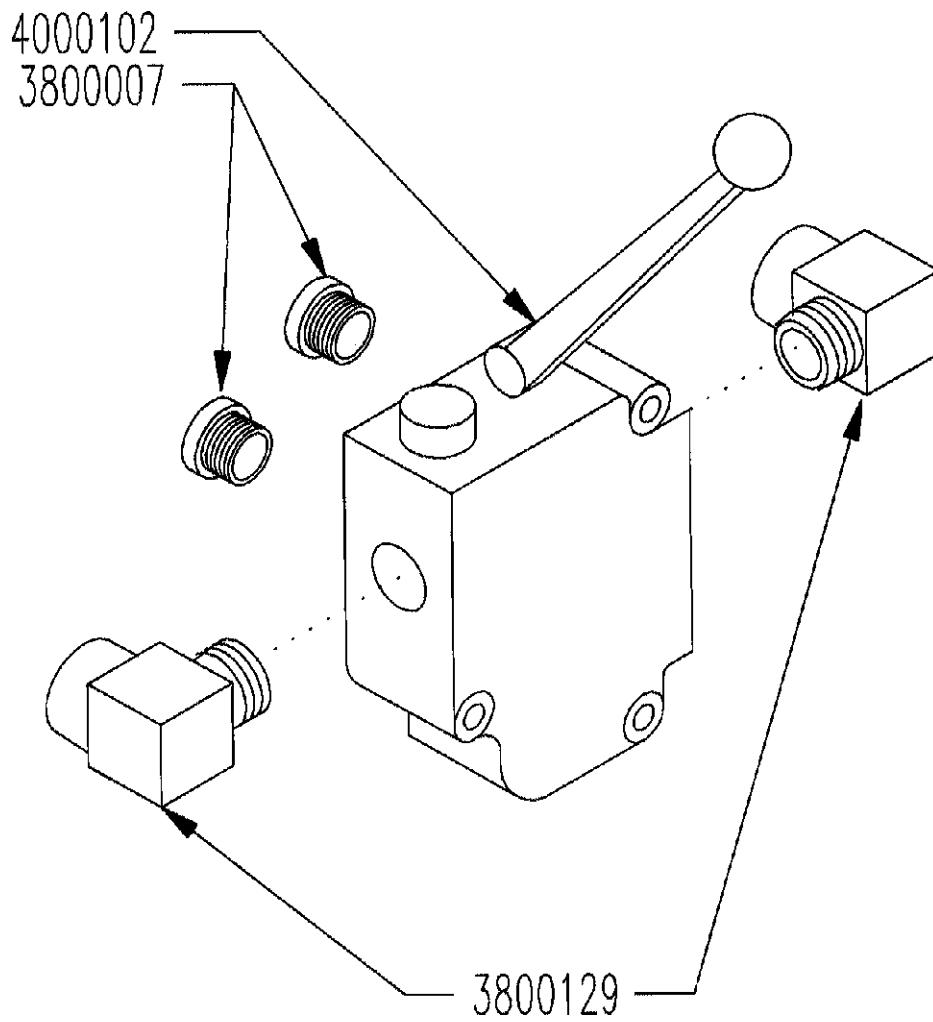

PART	QTY.	PART DESCRIPTION
4500807		VALVE\CNVYR\LIFT\ASSY\SUB
3800007	2	FTG\1/2MPX3/8FP\BUSH\LW
3800129	2	FTG\3/4MPX3/4FP\90D\ST;ELL
4000102	1	VALVE\HYD\1-SP\100040

OIL COOLER ASSEMBLY

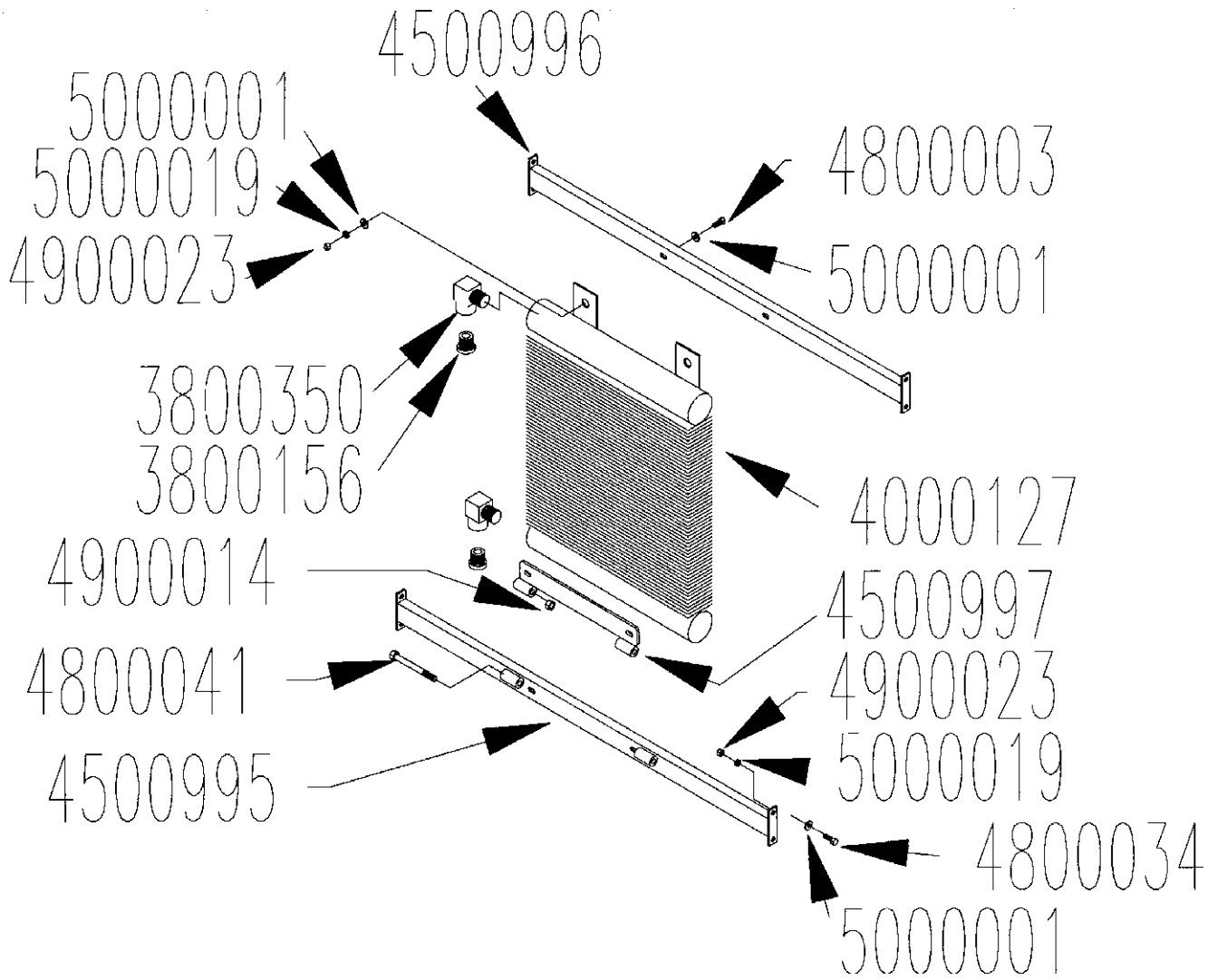

## OIL COOLER ASSEMBLY

<b>PART</b>	<b>QTY.</b>	<b>PART DESCRIPTION</b>
3800156	2	FTG\1MPX1\2FP\BUSH
3800350	2	FTG\1-5\16MORX1FP\90DEG\ST;EL
4000127	1	RAD\HYD\19-3\4X23X2\1-5\16FOR
4500995	1	BRKT\PVT\LOWER\COOLER\OIL
4500996	1	BRKT\UPPER\COOLER\OIL
4500997	1	BRKT\PVT\COOLER\OIL
4800003	4	BOLT\HEX\3\8X1
4800034	8	BOLT\HEX\3\8X1-1\2
4800041	2	BOLT\HEX\1\2X5
4900014	2	NUT\TPLCK\1\2\NC
4900023	12	NUT\TPLCK\3\8\NC
5000001	16	WASH\FLAT\3\8
5000019	12	WASH\LOCK\3\8

OIL TANK ASSEMBLY

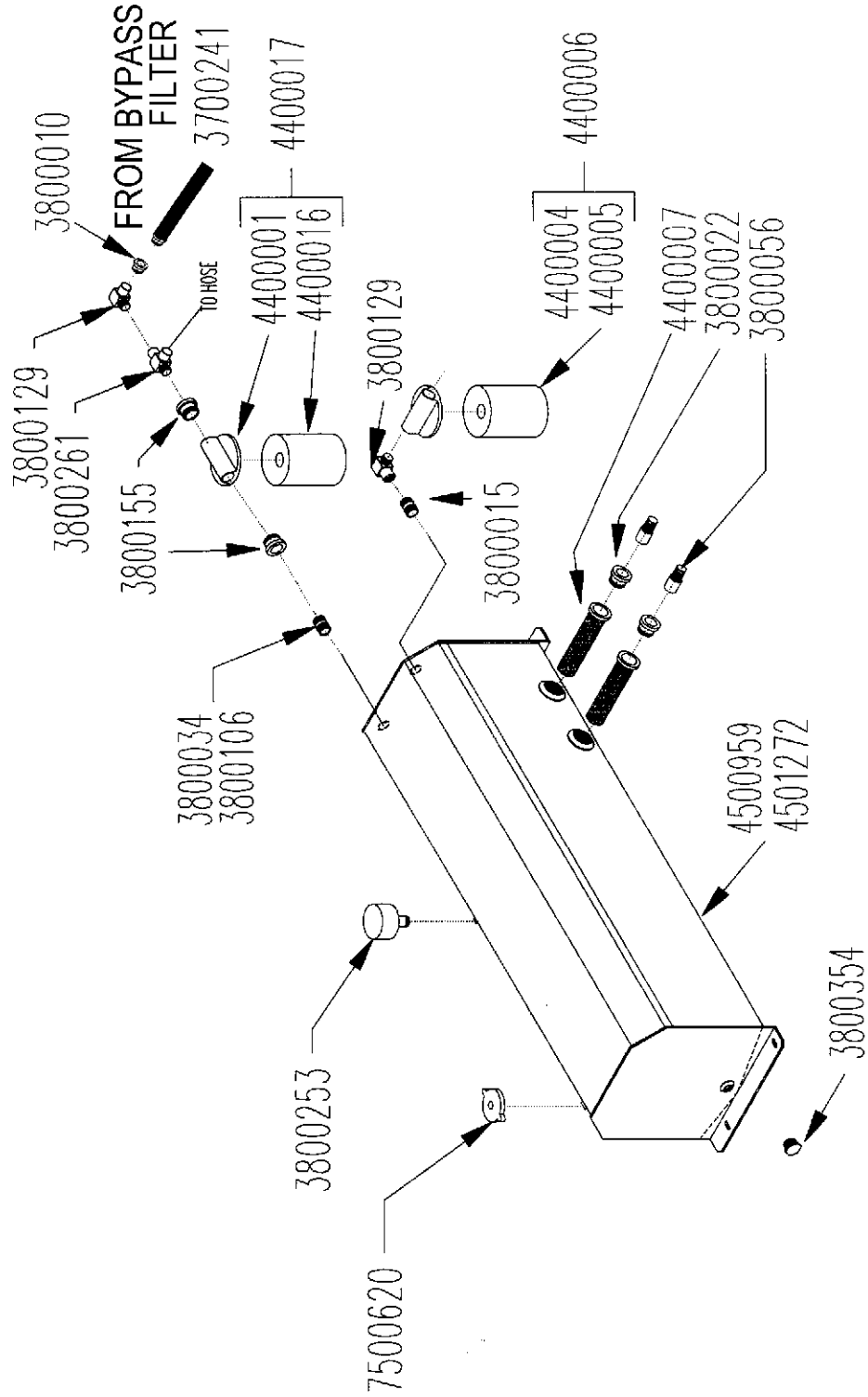

**OIL TANK ASSEMBLY**

<b>PART</b>	<b>QTY.</b>	<b>PART DESCRIPTION</b>
4501073		TANK\OIL\ASSY\SUB\H11E\97
3700241	1	HOSE\HYD\1/2X91
3800010	1	FTG\3/4MPX1/2FP\BUSH
3800015	1	FTG\3/4MPX2\NPL\1W
3800022	2	FTG\1-1/4MPX1FP\BUSH\1W
3800034	1	FTG\3/4MPX7-1/2\NPL\1W
3800056	2	FTG\1MPX1BARB\ADPT\1W
3800106	1	FTG\3/4MPX1-1/2\NPL\1W
3800129	2	FTG\3/4MPX3/4FP\90D\ST;EL
3800155	2	FTG\1-1/4MPX3/4FP\ADPT
3800253	1	FTG\3/4MP\VENT\>ABS-40
3800261	1	FTG\3/4FPX3/4MPX3/4FP\RUN;TEE
3800354	1	FTG\3/4MP\PLUG\ALN
4400001		FLTR\BASE\1-1/4FP\5.1D\>
4400004		FLTR\BASE\3/4FP\3.7D\>
4400005		FLTR\ELMT\10MICRON\3.7D>
4400006	2	FLTR\COMP\10MICRON\3.7D\>
4400006	1	FLTR\COMP\10MICRON\3.7D\>
4400007	2	FLTR\SCRN\2MPX1-1/4FP\25>
4400016		FLTR\ELMT\10MICRON\5.1D>
4400017	1	FLTR\COMP\10MICRON\5.1D\>
4500959	1	TANK\OIL\H1100E\SINGLE
4501272	1	TANK\OIL\H1100E\SINGLE for SN II0185 and up
7500620	1	CAP\OIL\4777\300 SERIES

**HYDRAULIC TANDEM PUMP\20-15\ASSEMBLY**

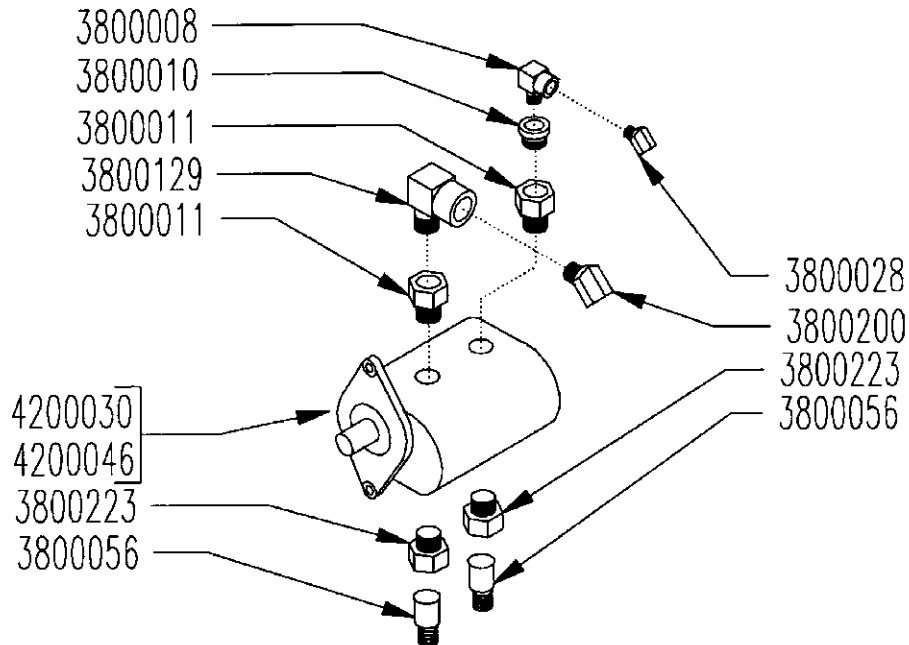

NOTE – FITTINGS SHOWN ARE FOR PUMP 4200030. PUMP 4200046 FITTINGS ARE EXCHANGED, 3800129 AND 3800200 ARE MOVED TO THE REAR PORT, AND 3800008, 3800010, AND 3800028 ARE MOVED TO THE FRONT PORT. PUMP 4200030 IS USED WITH CAT ENGINES. PUMP 4200046 IS USED WITH CUMMINS ENGINES.

PART	QTY.	PART DESCRIPTION
4500810	1	PUMP\HYD\TNDM\20-15\ASSY
3800008	1	FTG\1/2MPX1/2FP\90S\ST;ELL
3800010	1	FTG\3/4MPX1/2FP\BUSH
3800011	2	FTG\1-5/16MORX3/4FP\ADPT
3800028	1	FTG\1/2MPX1/2FP\45D\ST;ELL
3800056	2	FTG\1MPX1BARB\ADPT\LW
3800129	1	FTG\3/4MPX3/4FP\90D\ST;ELL
3800200	1	FTG\3/4MPX3/4FP\45D\ST;ELL
3800223	2	FTG\1-5/8MORX1FP\ADPT
4200030	1	20/15 DBL PUMP-WEBSTER For Cat 3306 & 3406 Engines
4200046		20/15 DBL PUMP-WEBSTER For Cummins N14 Engines
4200044		SEAL KITWEBSTERKSERIES



**HYDRAULIC MOTOR\8\ASSEMBLY**

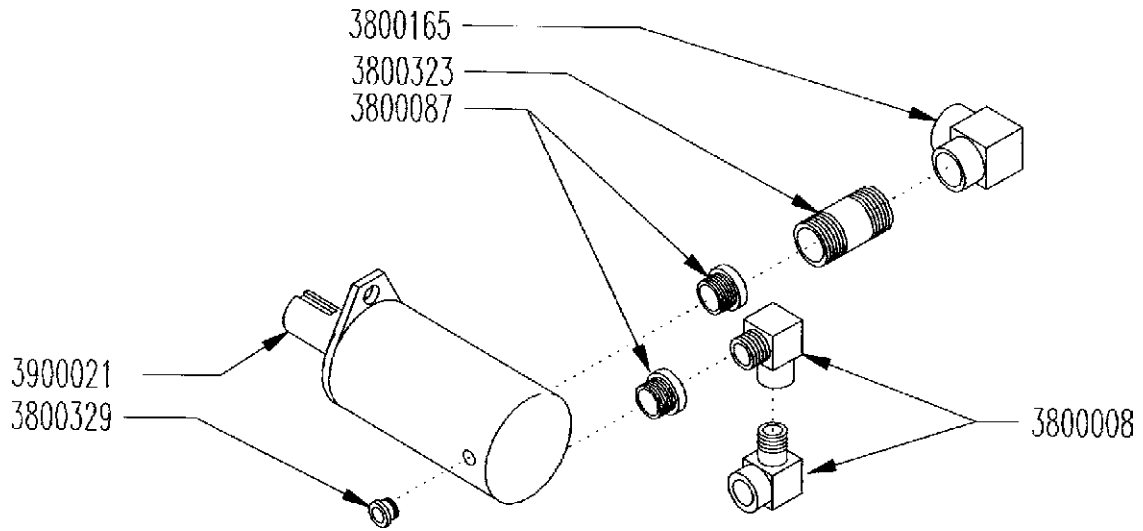

PART	QTY.	PART DESCRIPTION
4500811	1	MTR\HYD\8\ASSYSUB
3800008	2	FTG\1/2MPX1/2FP\90D\ST;ELL
3800087	2	FTG\7/8MORX1/2FP\ADPT
3800165	1	FTG\1/2FP\90D\ELL
3800323	1	FTG\1/2MPX2\NPL\LW
3800329	1	FTG\7/16MORX1/4FP\ADPT
3900021	1	MTR\HYD\8\2000SERIES see page 96

**GRINDER FRAME ASSEMBLY FOR SN GI0140 - GI0154**

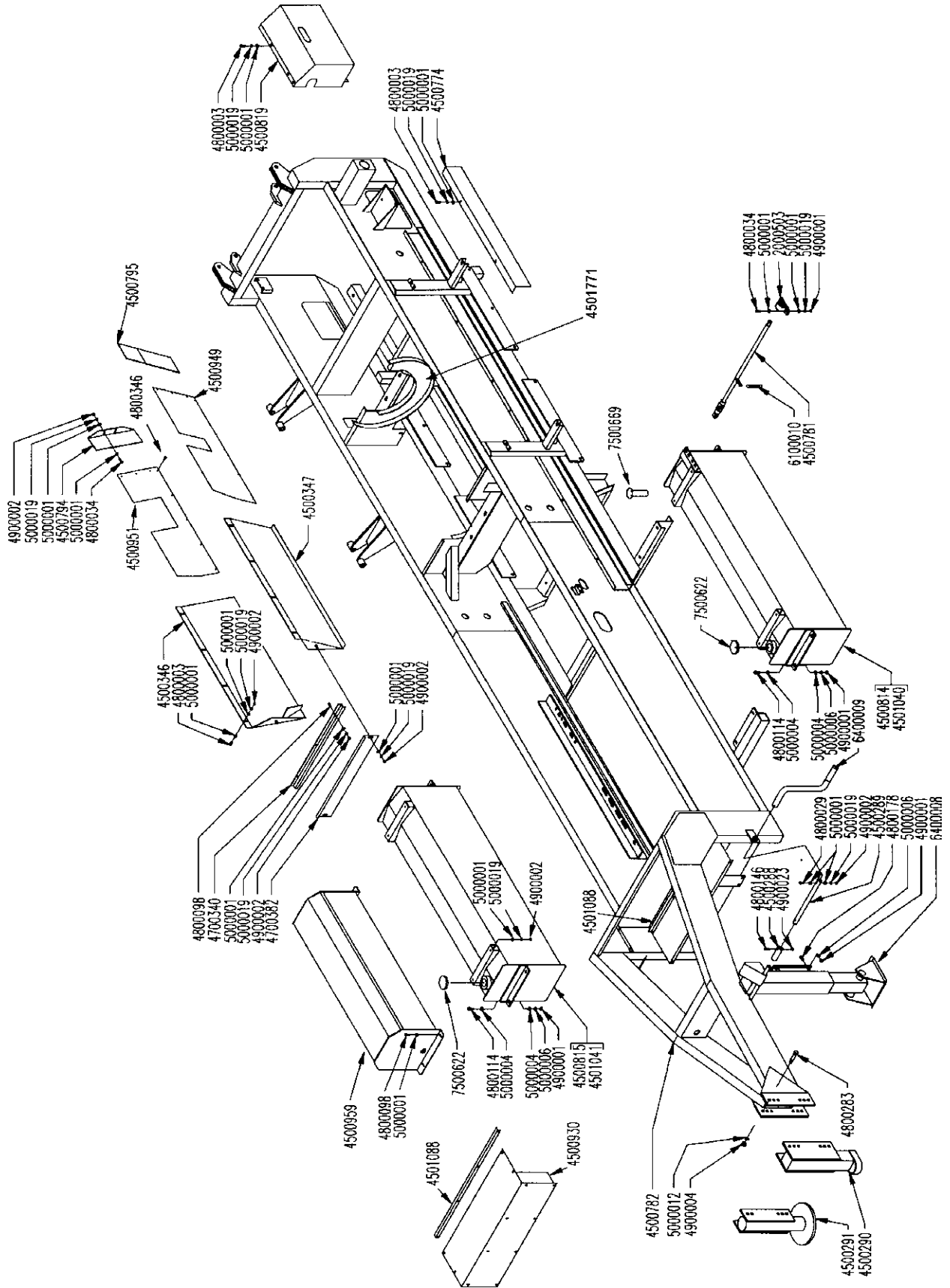

**GRINDER FRAME ASSEMBLY FOR SN GI0140 - GI0154**

<b>PART</b>	<b>QTY.</b>	<b>PART DESCRIPTION</b>
2000503	1	BRG\PB\1
4500288	1	JACK HANDLE EXT. COUPLER
4500289	1	JACK HANDLE EXTENSION
4500290	1	HITCH\BALL
4500291	1	5TH WHEEL HITCH
4500346	1	RIGHT HAND SIDE PANEL
4500347	1	LEFT HAND SIDE PANEL
4500774	3	CONDUCT\HOSE\HYD
4500781	1	EXT\LEVER\CLUTCH\H11E
3600302		U-JOINT\1"BORE\NO KW
3600308		HUB\CLUTCH\H11E
4500782	1	FRM\GRDR\MAIN\96;H11E
4500794	1	GUIDE\RH\CNVYR\MATL\REAR
4500795	1	GUIDE\LH\CNVYR\MATL\REAR
4500814	1	TANK\FUEL\LH\84GAL\H11E
4500815	1	TANK\FUEL\RH\84GAL\H11E
4500819	1	COVER\VL\HYD\REAR\H11E
4500820		FRAME\GRDR\H11E\ASSY\SUB
4500930	1	CVR\BOX\BTTRY\H11E96
4500949	1	GUIDE\MATL\CNVYR\BELLY\LH
4500951	1	GUIDE\MATL\CNVYR\BELLY\RH
4500959	1	TANK\OIL\H1100E\SINGLE
4501040	1	TANK\FUEL\LH\105GAL
4501041	1	TANK\FUEL\RH\105GAL
4501088	2	STRAP\ANGLE\BATTERY\H1100E
4700340	1	RETAINER\CNVYR\DR
4700382	1	CLOSURE FRONT
4800003	19	BOLT\HEX\3/8X1
4800029	1	BOLT\HEX\3/8X2-12
4800034	6	BOLT\HEX\3/8X1-1/2
4800098	7	BOLT\HEX\3/8X1-1/4\INC
4800114	8	BOLT\HEX\1/2X2
4800123	8	PIN\COT\1/8X1-1/2
4800146	1	BOLT\3/8X2
4800178	4	BOLT\HEX\1/2X1-3/4
4800283	4	BOLT\HEX\3/4X2-1/4
4800346	10	SCR\SDT\#10X3/4
4900001	14	NUT\HEX\1/2
4900002	22	NUT\HEX\3/8
4900004	4	NUT\HEX\3/4
4900005	4	NUT\HEX\5/8
4900023	1	NUT\TPLCK\3/8
4900029	1	NUT\WELD\3/8\NF
5000001	46	WASH\FLAT\3/8
5000003	4	WASH\LOCK\5/8
5000004	16	WASH\FLAT\1/2
5000006	12	WASH\LOCK\1/2
5000012	4	WASH\LOCK\3/4
5000019	35	WASH\LOCK\3/8
5800608	1	JACK\25000\TWO;SPEED
5800609	1	JACK HANDLE 25000 LG
6100010	1	SPRING TENSION
7500622		CAP\FUEL\ORDER 7500811
7500669		GUAGE\SENDING\UNIT
7500811	2	CAP\FUEL\5343-15\600SERS\WLOWPRESS;RELIEF
1100128		CHAIN\5/16\HIGHTEST
5800002		HOOK\SLIP\5/16
7500298	2	FLG\TANK\FUEL

# GRINDER FRAME ASSEMBLY FOR SN HI0155 AND UP

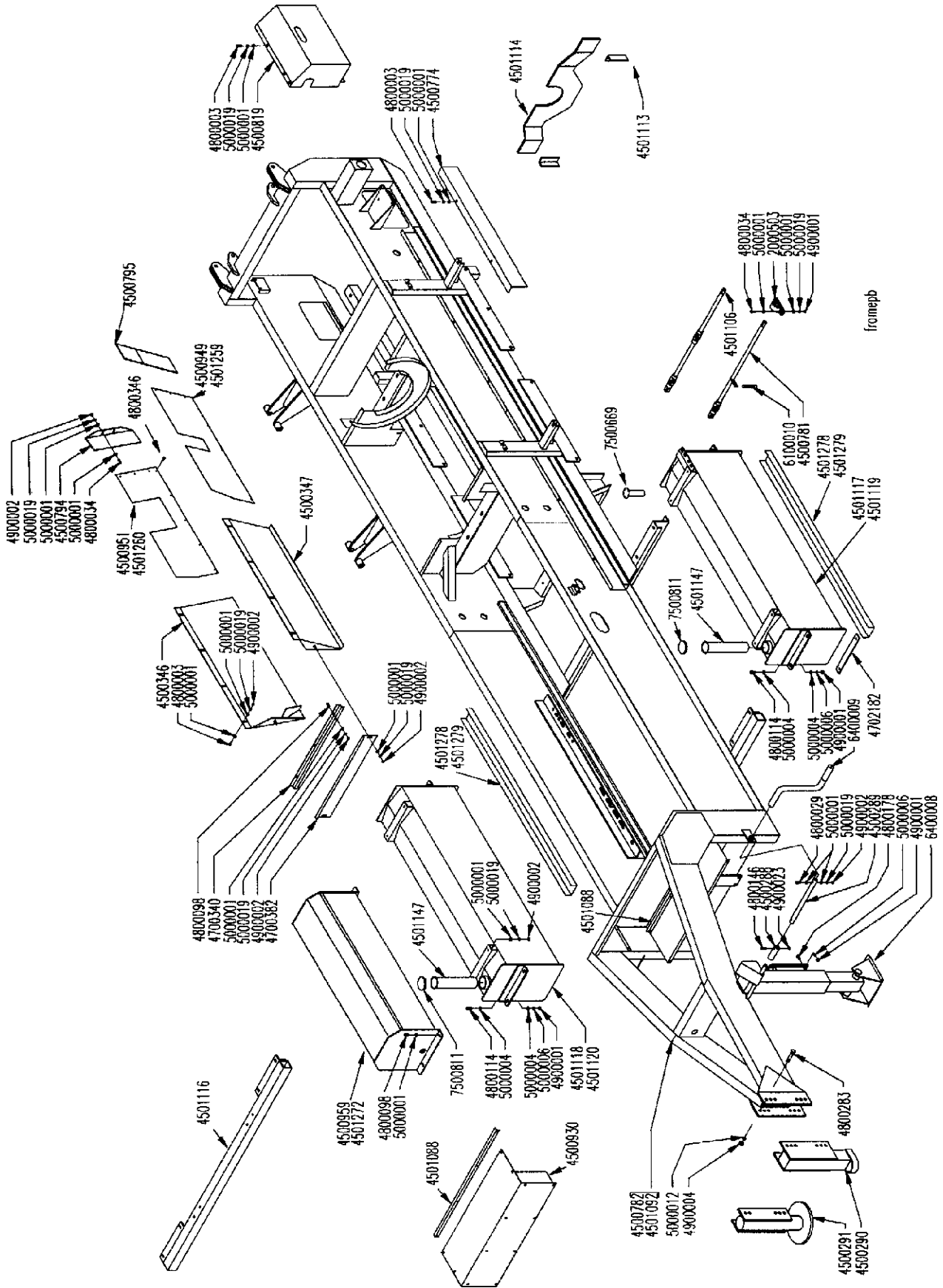

**GRINDER FRAME ASSEMBLY FOR SN H10155 AND UP**

<b>PART</b>	<b>QTY.</b>	<b>PART DESCRIPTION</b>
2000503	1	BRG\PB\1 See page 74 for H10165 and up
4500288	1	JACK HANDLE EXT. COUPLER
4500289	1	JACK HANDLE EXTENSION
4500290	1	HITCH\BALL
4500291	1	5TH WHEEL HITCH
4500346	1	RIGHT HAND SIDE PANEL
4500347	1	LEFT HAND SIDE PANEL
4500774	3	COV\DUCT\HOSE\HYD
4500781	1	EXT\LEVER\CLUTCH\H11E for SN up to G10154
4500782	1	FRM\GRDR\MAIN\96;H11E
4500794	1	GUIDE\RH\CNVYR\MATL\REAR
4500795	1	GUIDE\LH\CNVYR\MATL\REAR
4500819	1	COVER\VLV for \HYD\REAR\H11E
4500820	1	FRAME\GRDR\H11E\ASSY\SUB
4500930	1	CVR\BOX\BTRY\H11E96
4500949	1	GUIDE\MATL\CNVYR\BELLY\LH
4500951	1	GUIDE\MATL\CNVYR\BELLY\RH
4500959	1	TANK\OIL\H1100E\SINGLE for SN H10155 to H10184
4501088	2	STRAP\ANGLE\BATTERY\H1100E
4501106	1	EXT\LEVER\CLUTCH\H11E for SN H10155 to H10164
3600302		U-JOINT\1"BORE\NO KW
		See page 74 for H10165 and up
4501113	2	BRKT\SPPT\CLUTCH\TWINDISC
4501114	1	BRKT\SPPT\HSG\CLUTCH\TWINDISC
4501116	1	BRKT\TANK\FUEL for SN H10165 and up
4501117	1	TANK\FUEL\LH\84GAL\H11E for SN H10165 and up
4501118	1	TANK\FUEL\RH\84GAL\H11E SN H10165 and up
4501119	1	TANK\FUEL\LH\105GAL for SN H10165 and up
4501120	1	TANK\FUEL\RH\105GAL for SN H10165 and up
4501147	2	FLNG\TUBE\FILL\TANK\FUEL
4501171		PL\BOX\CYL\REAR
4501259	1	GUIDE\MATL\CNVYR\BELLY\LH for SN H10185 and up
4501260	1	GUIDE\MATL\CNVYR\BELLY\RH for SN H10185 and up
4501272	1	TANK\OIL\H1100E\SINGLE for SN H10185 and up
4501278	2	CVR\HOSE\SUCT\FUEL\84GAL
4501279	2	CVR\HOSE\SUCT\FUEL\107GAL
4700340	1	RETAINER\CNVYR\DR
4700382	1	CLOSURE FRONT
4800003	19	BOLT\HEX\3/8X1
4800029	1	BOLT\HEX\3/8X2-12
4800034	6	BOLT\HEX\3/8X1-1/2
4800098	7	BOLT\HEX\3/8X1-1/4\NC
4800114	8	BOLT\HEX\1/2X2
4800123	8	PIN\COT\1/8X1-1/2
4800146	1	BOLT\3/8X2
4800178	4	BOLT\HEX\1/2X1-3/4
4800283	4	BOLT\HEX\3/4X2-1/4
4800346	10	SCR\SDT\#10X3/4
4900001	14	NUT\HEX\1/2
4900002	22	NUT\HEX\3/8
4900004	4	NUT\HEX\3/4
4900005	4	NUT\HEX\5/8
4900023	1	NUT\TPLCK\3/8
4900029	1	NUT\WELD\3/8\NF
5000001	46	WASH\FLAT\3/8
4501361		DBL\SEAL\CNVYR\BLLY\FR
4501363		BELT\SEAL\CNVYR\BLLY\FR
5000003	4	WASH\LOCK\5/8
5000004	16	WASH\FLAT\1/2
5000006	12	WASH\LOCK\1/2
5000012	4	WASH\LOCK\3/4
5000019	35	WASH\LOCK\3/8
5800608	1	JACK\25000\TWO;SPEED
5800609	1	JACK HANDLE 25000 LG
6100010	1	SPRING TENSION
7500811	2	CAP\FUEL\5343-15\600 SER\W\LOW PRESS RELIEF
7500699		GUAGE\SENDING\UNIT
4702182	4	CSHN\TANK\FUEL\HD1098
4501771		PL\BOX\CYL\REAR
1100128		CHAIN\5/16\HIGHTEST
5800002		HOOK\SLIP\5/16

PLATFORM ASSEMBLY - SN GI0140 - HI0184

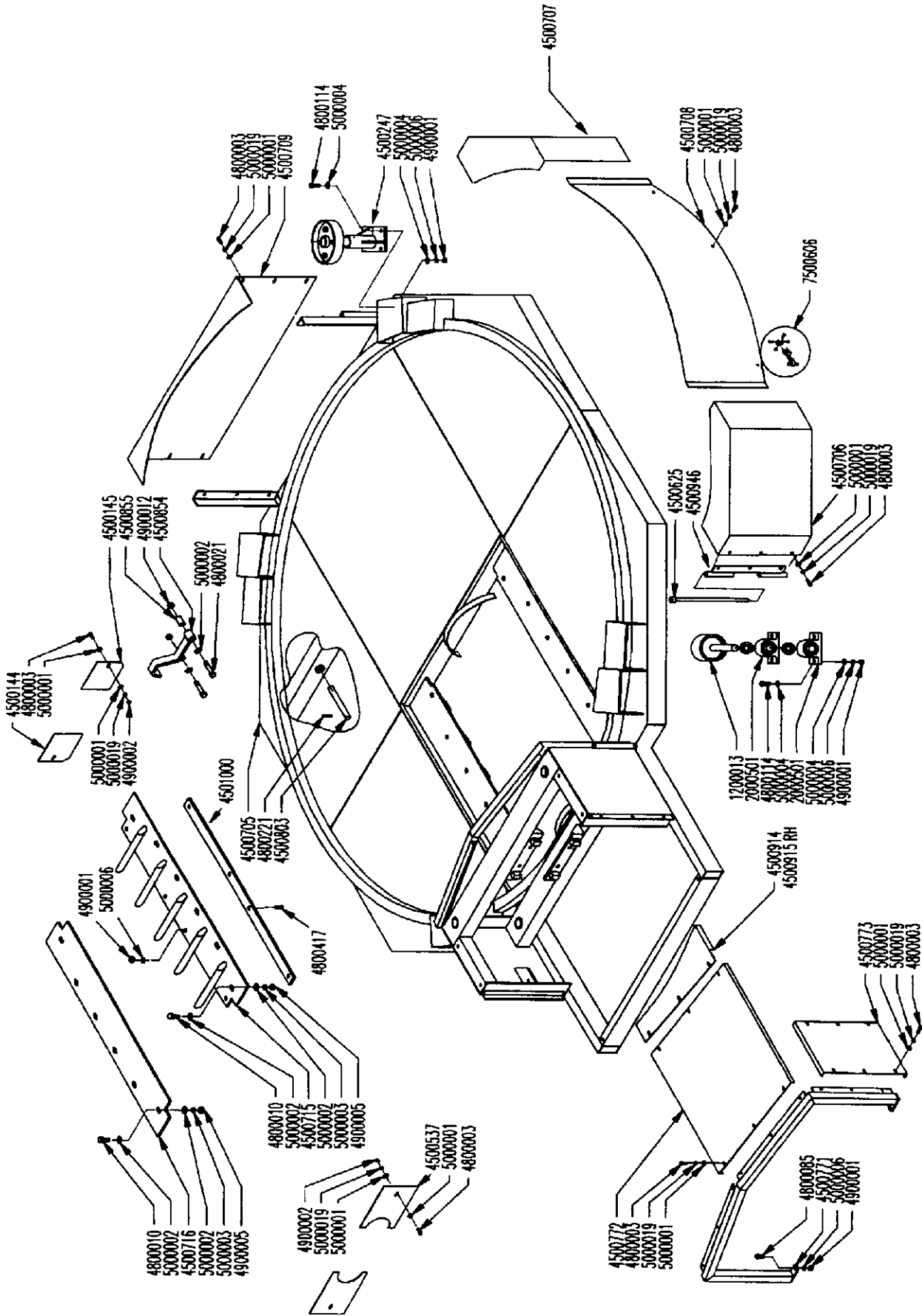

**PLATFORM ASSEMBLY - SN GI0140 - HI0184**

<b>PART</b>	<b>QTY.</b>	<b>PART DESCRIPTION</b>
4500704		PLTFRM\ASSY\SUB\H1100E
1200013	4	RLLR\TUB\1-1/2\W/O;FLANGE
2000501	8	BRG\PILLOW-BLOCK\1-1/2\2-BOLT
4500144	1	DOOR\ROTOR\REAR\RH
4500145	1	DOOR\ROTOR\REAR\LH
4500247	4	PRESSURE ROLLER COMPLETE see page 95
4500537	4	DOOR\ROTOR\FRONT
4500625	4	PIN\HINGE\GUARD
4500705	1	PLATFORM\TUB\TILT\80DEG
4500706	2	GUARD\ROLLER\LH
4500707	2	GUARD\ROLLER\RH
4500708	2	GUARD\CHAIN\TUB\SIDE
4500709	1	GUARD\CHAIN\TUB\REAR
4500715	1	HOLDDOWN\SCREEN\5-TOOTH
4500716	1	HOLDDOWN\SCREEN
4500771	1	BRKT\SHEILD\FRONT\TUBDRIVE
4500772	2	SHLD\DRIVE\TUB\TOP\HOUSE
4500773	2	SHLD\DRIVE\TUB\SIDE\SHOUSE
4500803	2	PIN\PLATFORM\HINGE\9X1
4500854	4	BRKT\HOLDDOWN\SCREEN
4500855	4	BUSH\BRACKET\HOLDDOWN\SCREEN
4500914	1	CVR\DRIVE\TUB\REAR\LH
4500915	1	CVR\DRIVE\TUB\REAR\RH
4500946	4	HINGE\GUARD\ROLLER
4501000	1	SHIM\HOLDDOWN\SCRN\1/2X2X47-1/2
4800003	52	BOLT\HEX\3/8X1
4800010	12	BOLT\HEX\5/8X2
4800021	4	BOLT\HEX\5/8X3
4800082	16	BOLT\HE1/2X1-1/2
4800085	2	BOLT\HEX\1/2X1
4800114	16	BOLT\HEX\1/2X2
4800221	2	PIN\RLLD\1/4X2
4800417	4	SCR\CSK\ALN\1/2X2\NC
4900001	38	NUT\HEX\1/2\NC
4900002	10	NUT\HEX\3/8\NC
4900005	12	NUT\HEX\5/8\NC
4900012	8	NUT\TPLCK\5/8\NC
5000001	56	WASH\FLAT\3/8
5000002	32	WASH\FLAT\5/8
5000003	12	WASH\LOCK\5/8
5000004	64	WASH\FLAT\1/2
5000006	38	WASH\LOCK\1/2
5000019	52	WASH\LOCK\3/8
7500606	8	LATCH\35-MAUSTIN

# PLATFORM ASSEMBLY - SN 1100185 AND UP

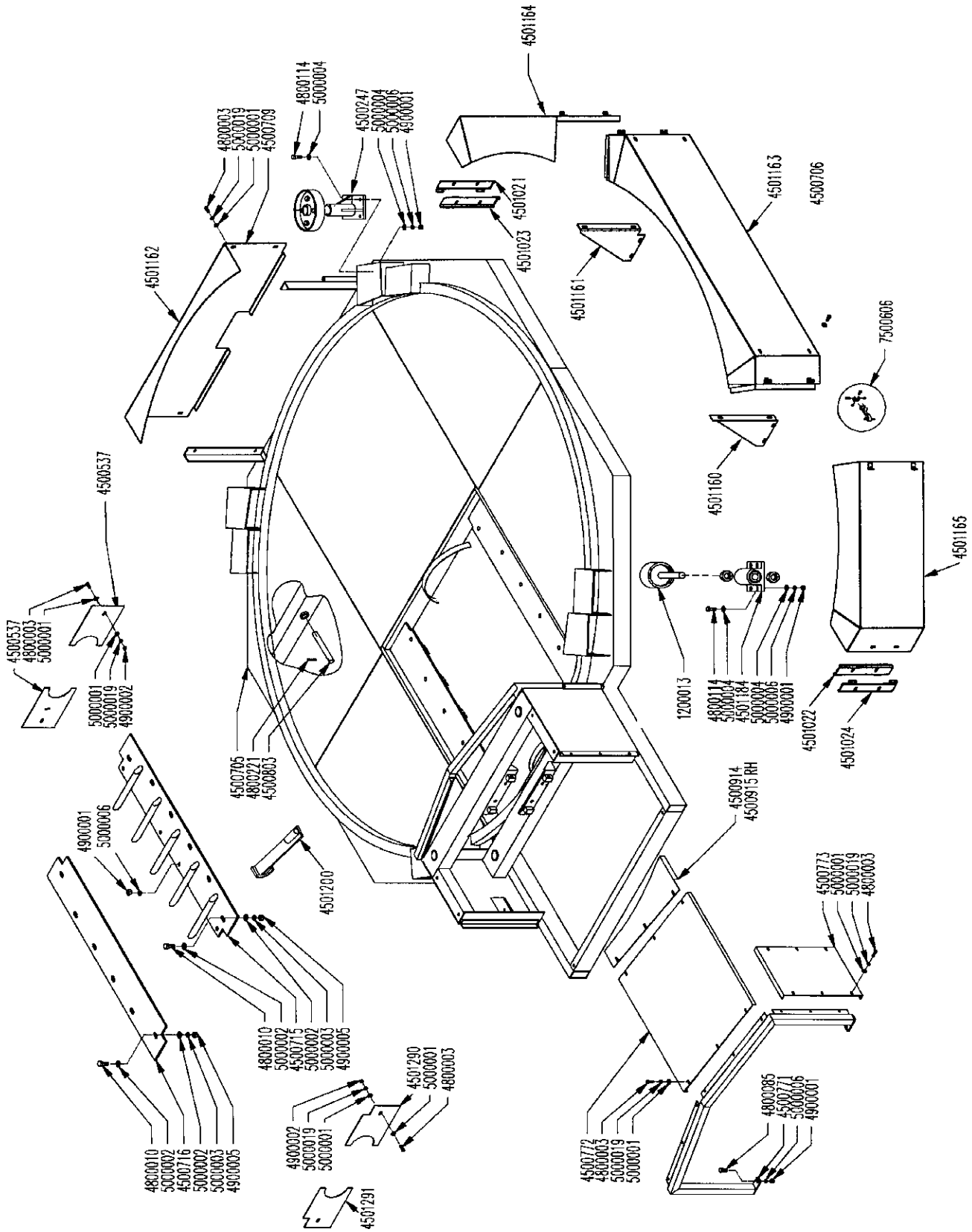



**PLATFORM ASSEMBLY - SN 1100185 AND UP**

<b>PART</b>	<b>QTY.</b>	<b>PART DESCRIPTION</b>
1200013	4	RLLR\TUB\1-1/2\W/O;FLANGE see page 94
4500247	4	PRESSURE ROLLER COMPLETE see page 95
4500705	1	PLATFORM\TUB\TILT\80DEG
4500715	1	HOLDDOWN\SCREEN\5-TOOTH
4500716	1	HOLDDOWN\SCREEN
4500771	1	BRKT\SHEILD\FRONT\TUBDRIVE
4500772	2	SHLD\DRIVE\TUB\TOP\HOUSE
4500773	2	SHLD\DRIVE\TUB\SIDE\HOUSE
4500803	2	PIN\PLATFORM\HINGE\9X1
4500914	1	CVR\DRIVE\TUB\REAR\LH
4500915	1	CVR\DRIVE\TUB\REAR\RH
4501021	2	BRKT\HINGE\MALE\LH
4501022	2	BRKT\HINGE\MALE\RH
4501023	2	BRKT\HINGE\FEMALE\LH
4501024	2	BRKT\HINGE\FEMALE\RH
4501160	2	BRKT\SHLD\LH\CHAIN\DRIVE\TUB\H11E
4501161	2	BRKT\SHLD\RH\CHAIN\DRIVE\TUB\H11E
4501162	1	SHLD\CHAIN\DRIVE\TUB\REAR
4501163	2	SHLD\CHAIN\DRIVE\TUB\SIDE
4501164	2	SHLD\CHAIN\DRIVE\LH
4501165	2	SHLD\CHAIN\DRIVE\RH
4501184	4	BRG\PB\RLLR\TUB\ASYW\BEARING INSERTS
4501200	4	HOOK\SCRN\GRDR\BOLTED
4501290	1	CVR\BRG\RTRW\OFFSET\LH
4501291	1	CVR\BRG\RTRW\OFFSET\RH
4800003	52	BOLT\HEX\3/8X1
4800010	12	BOLT\HEX\5/8X2
4800021	4	BOLT\HEX\5/8X3
4800082	16	BOLT\HE1/2X1-1/2
4800085	2	BOLT\HEX\1/2X1
4800114	16	BOLT\HEX\1/2X2
4800221	2	PIN\RLLD\1/4X2
4800417	4	SCR\CSK\ALN\1/2X2\NC
4900001	38	NUT\HEX\1/2\NC
4900002	10	NUT\HEX\3/8\NC
4900005	12	NUT\HEX\5/8\NC
4900012	8	NUT\TPLCK\5/8\NC
5000001	56	WASH\FLAT\3/8
5000002	32	WASH\FLAT\5/8
5000003	12	WASH\LOCK\5/8
5000004	64	WASH\FLAT\1/2
5000006	38	WASH\LOCK\1/2
5000019	52	WASH\LOCK\3/8
7500606	8	LATCH\35-M/AUSTIN

# TUB DRIVE ASSEMBLY

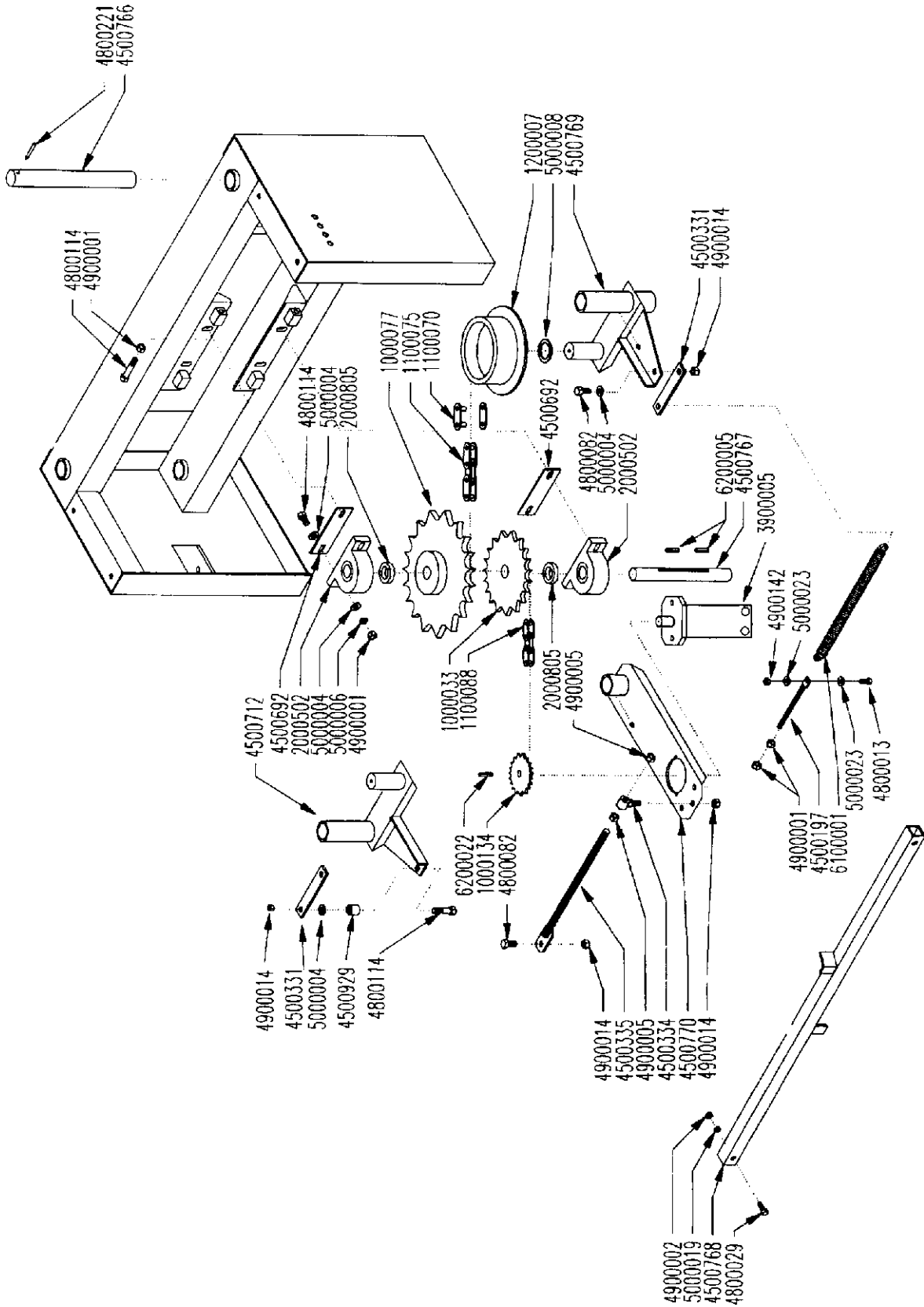

## TUB DRIVE ASSEMBLY

PART	QTY.	PART DESCRIPTION
4500710		TUBDRIVE ASSEMBLY
1000033	1	SPKT\60\30\1-1/4\1/4KW
1000077	1	SPKT\80\30\1-1/4\1/4KW
1000134	1	SPKT\60\B\12\1-1/4\5/16KW
1100062	1	CHAIN\60\CL
1100063		CHAIN\60\OL
1100070	1	CHAIN\2080\CL
1100071		CHAIN\2080\OL
1100075	1	CHAIN\2080\177
1100088	1	CHAIN\60\43
1200007	2	RLL#6
2000502	2	BRG\PB\1-1/4
2000805	2	CLLR\SHFT\1-1/4\W\SET
3900005	1	MTR\HYD\14.9\2000\SAE;A see page 96
4500197	2	BOLT\TENSION\SPRING
4500331	2	LINK\SPRING\1/4X6-1/4
4500334	1	BRKT\BOLT\TIGHTNER
4500335	1	BRKT\TIGHTENER\ORBIT;MOTOR
4500692	4	SHIM\BRG\TUB DR\10GAX2X7
4500712	1	BRKT\ARM\SWING\RH
4501332		BRKT\ARM\SWING\RH (4501332 & 4501331 - UPDATE FOR 4500712 & 1200007)
4501331		RLLR\DR\TUB
4500766	2	PIN\PIVOT\ARM\SWING\DRIVE
4500767	1	SHFT\DRIV\DECK\TUB
4500768	1	BRKT\SPRING\IDLER\SWING
4500769	1	BRKT\ARM\SWING\LH
4501332		BRKT\ARM\SWING\RH (4501332 & 4501331 - UPDATE FOR 4500712 & 1200007)
4501331		RLLR\DR\TUB
4500770	1	BRKT\MOTOR\ORBIT\TUB DRIVE
4500929	1	SPCR\LINK\SPG\SWING ARM
4800013	2	BOLT\HEX\5/16X1
4800029	2	BOLT\HEX\3/8X2-1/2
4800082	3	BOLT\HEX\1/2X1-1/2
4800114	7	BOLT\HEX\1/2X2
4800221	2	PIN\RLLD\1/4X2
4900001	8	NUT\HEX\1/2\NC
4900002	2	NUT\HEX\3/8\NC
4900005	2	NUT\HEX\5/8\NC
4900014	3	NUT\TPLCK\1/2\NC\.500
4900142	2	NUT\TPLCK\5/16
5000004	10	WASH\FLAT\1/2
5000006	4	WASH\LOCK\1/2
5000008	4	WASH\1-1/2 MACH;BUSH(nr)
5000019	2	WASH\LOCK\3/8
5000023	4	WASH\FLAT\5/16
6100001	2	SPRING.156OT 63/64OD 13 LIH
6200005	2	KEY\SQ\1/4X1-1/2
6200022	1	KEY\SQ\5/16X1-1/2\HARDENED

**TANDEM AXLE ASSEMBLY**

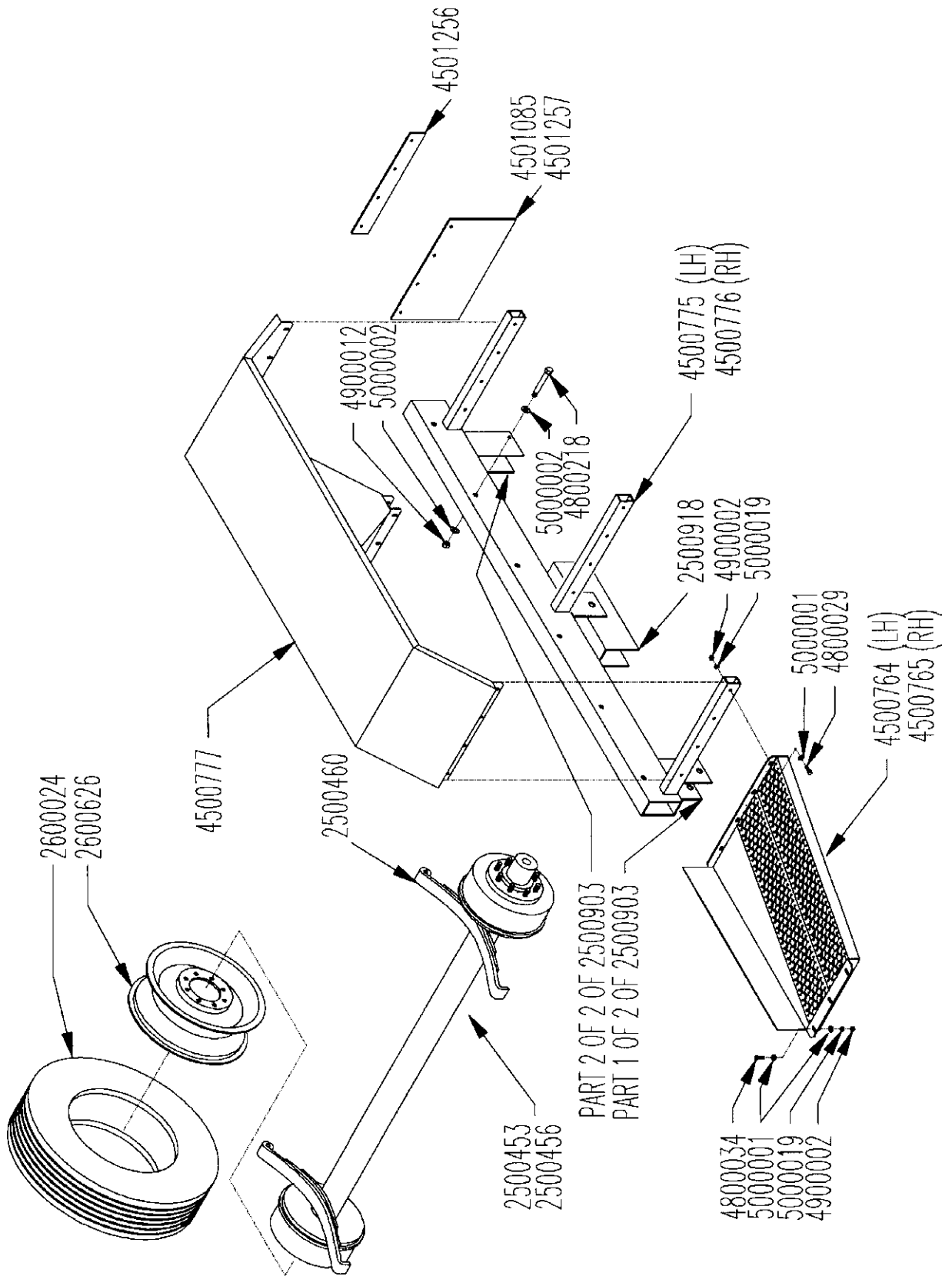

**TANDEM AXLE ASSEMBLY**

<b>PART</b>	<b>QTY.</b>	<b>PART DESCRIPTION</b>
4500830		AXLE\ELEC\10K\ASSY\H1100E
2500453	2	AXLE\ELEC\10K
2500460		AXLE\SPR\LEAF\10K\72-43-1
2500461		AXLE\SPR\LEAF\12K\72-44-1
2500903		MNT\SUSP\HAP103\KIT
2500918		MNT\SUSP\HAP103\DUAL HANGER KIT
2600024	8	9.50X16.5 B.E. BIAS 10 PLY
2600626	8	16.5 X 6.75 DUAL WHEEL
2600808		TIRE\ASSY\950X16.5X10PLY (2600024 + 2600606)
4500764	1	STEP\FRML\H\FNDR\TNDM
4500765	1	STEP\FRMR\H\FNDR\TNDM
4500775	1	FRMAXLE\TNDM\LH\BOLTED\10K
4500776	1	FRMAXLE\TNDM\RH\BOLTED\10K
4500777	2	FNDR\AXLE\TNDM\10K
4501085	2	FLAP\MUD
4800029	24	BOLT\HEX\3/8X2-1/2
4800034	6	BOLT\HEX\3/8X1-1/2
4800218	12	BOLT\HEX\5/8X5-1/2
4900002	30	NUT\HEX\3/8\NC
4900012	12	NUT\TPLCK\5/8\NC
5000001	44	WASH\FLAT\3/8
5000002	24	WASH\FLAT\5/8
5000019	30	WASH\LOCK\3/8
4501086		OPTN\AXLE\AIR\TNDM\ASSY
2500456	2	AXLE\AIR\10K\COMP\74X46\SPRINGS UNDERSLUNG
2500921		BK\ABS\PACKAGE\24\ASGL
2500460		AXLE\SPR\LEAF\10K\72-43-1
2500461		AXLE\SPR\LEAF\12K\72-44-1
2500903		MNT\SUSP\HAP103\KIT
2500918		MNT\SUSP\HAP103\DUAL HANGER KIT
2600024	8	9.50X16.5 B.E. BIAS 10 PLY
2600626	8	16.5 X 6.75 DUAL WHEEL
2600808		TIRE\ASSY\950X16.5X10PLY (2600024 + 2600606)
4500764	1	STEP\FRML\H\FNDR\TNDM
4500765	1	STEP\FRMR\H\FNDR\TNDM
4500775	1	FRMAXLE\TNDM\LH\BOLTED\10K
4500776	1	FRMAXLE\TNDM\RH\BOLTED\10K
4500777	2	FNDR\AXLE\TNDM\10K
4501256	2	BRKT\FLAP\MUD\20K
4501257	2	FLAP\MUD\23-1/2X12X1/4\20K
4800029	24	BOLT\HEX\3/8X2-1/222
4800034	6	BOLT\HEX\3/8X1-1/2
4800218	12	BOLT\HEX\5/8X5-1/2
4900002	30	NUT\HEX\3/8\NC
4900012	12	NUT\TPLCK\5/8\NC
5000001	44	WASH\FLAT\3/8
5000002	24	WASH\FLAT\5/8
5000019	30	WASH\LOCK\3/8

ROTOR ASSEMBLY - SN GI0140 - HI0184

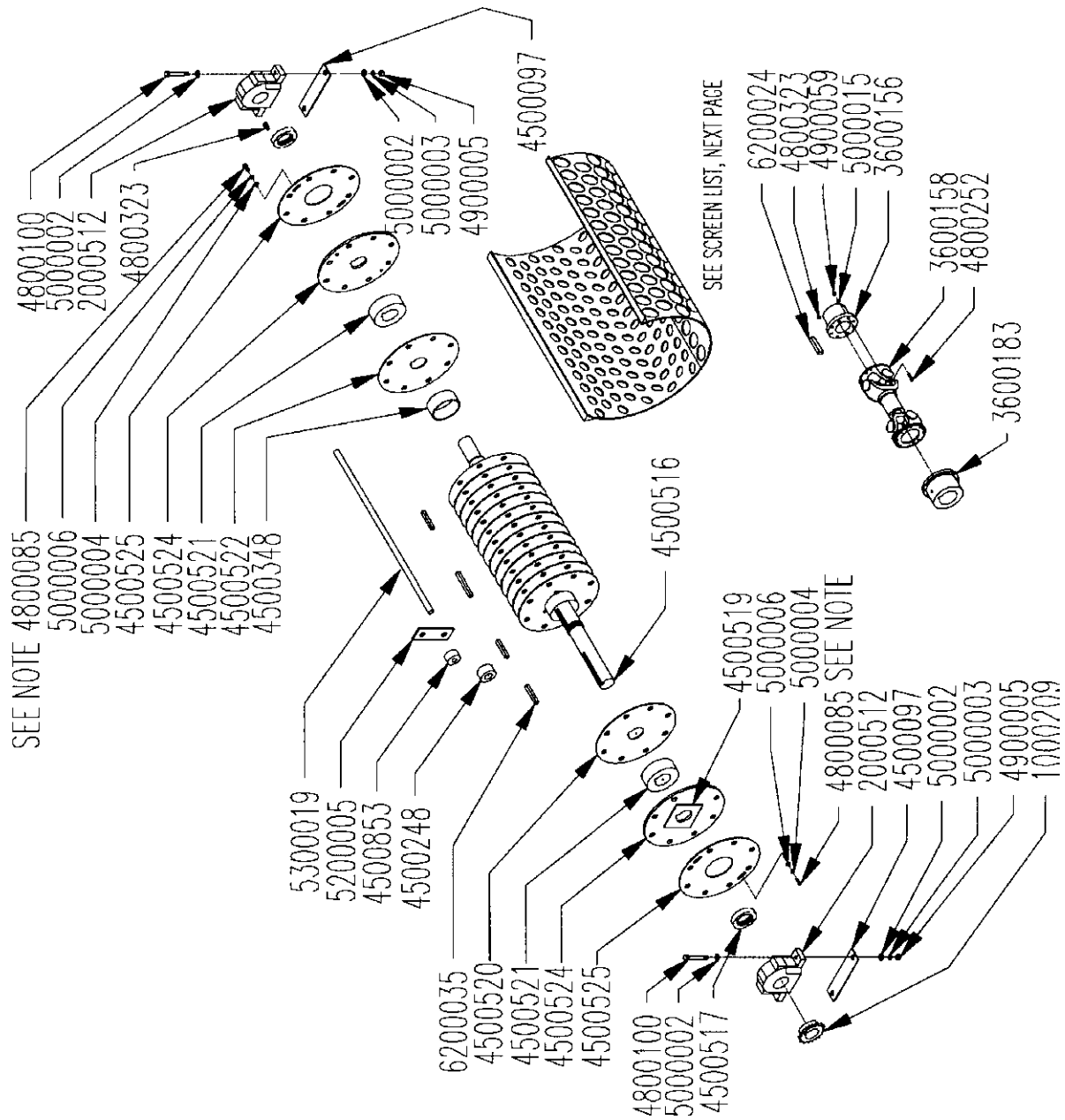

**ROTOR ASSEMBLY - SN GI0140 - HI0184**

<b>PART</b>	<b>QTY.</b>	<b>PART DESCRIPTION</b>
4500696		ROTOR\SUB ASSEMBLY
4500847		ROTOR\NEW50X15\16ROD\W\PLATES
1000209	1	SPKT\60\20\2SS\NO;KW
2000512	2	BRG\PB\3
3600156	1	FLANGE 3" ID 1710
3600158	1	1710 DRIVE LINE 18" COMP.
3600183		FLG\3-1/2IDX4L\1710\DRLIN
4500097	4	SHIM\BRG\3\16X3X11-3/4
4500248	48	1" HAMMER SPACER
4500348	16	1.878 CYLINDER SPACER
4500516	1	4-1/2" CYLINDER SHAFT
4500517	2	CYLINDER NUT 4-1/2" SHAFT
4500519	2	4-1/2" THRUST WASHER
4500520	5	1/2" PLATE FACED BOTH SIDES
4500521	6	SOLID CYLINDER SPACER
4500522	16	1/2" PLATE GROOVED 4.5"ID
4500524	2	1/2" CYLINDER END PLATE
4500525	2	1/4" MOVABLE PLATE
4500853	88	SPCR\SHOCK\HAMMER\RTR
4800085	4	BOLT\HEX\1/2X1
4800100	4	BOLT\HEX\5/8X4
4800252	16	BOLT\7\16X1-3/8\GR8
4800323	2	SCR\SET\ALN\1/2X1\NC
4800326	16	SCR\SET\ALN\1/2X1/2\NC
4900005	4	NUT\HEX\5/8\NC
4900059	16	NUT\HEX\7/16\NF
5000002	8	WASH\FLAT\5/8
5000003	4	WASH\LOCK\5/8
5000004	4	WASH\FLAT\1/2
5000006	4	WASH\LOCK\1/2
5000015	16	WASH\LOCK\7/16
5200005	88	HMMR\1/2"AB\2-HOLE
5300019	8	ROD\HMMR\15\16X50
6200024	1	KEY\SQ\3/4X4
6200035	4	KEY\RECT\1/2X5/8X6-1/4

**NOTE: #4800085 MUST HAVE HEAD MACHINED OFF TO 1/2 THE ORIGINAL THICKNESS.**

**SCREEN LIST - all screens 1/4" thick**

<b>PART</b>	<b>DESCRIPTION</b>
5400091	SCRN\2HL\1/4\SLTD\H1100
5400095	SCRN\1/8HL\1/4\H1100
5400051	SCRN\3HL\1/4\H1100
5400074	SCRN\3/16HL\1/4\H1100
5400090	SCRN\3HL\1/4\SLTD\H1100
5400052	SCRN\1/4HL\1/4\H1100
5400062	SCRN\4HL\1/4\H1100
5400053	SCRN\3/8HL\1/4\H1100
5400092	SCRN\4HL\1/4\SLTD\H1100
5400054	SCRN\1/2HL\1/4\H1100
5400102	SCRN\5HL\1/4
5400055	SCRN\5/8HL\1/4\H1100
5400110	SCRN\6HL\1/4\H1100E
5400056	SCRN\3/4HL\1/4\H1100
5400111	SCRN\7HL\1/4\H1100E
5400049	SCRN\1HL\1/4\H1100
5400103	"8" SCREEN\1/4 HR PLATE"
5400066	SCRN\1 1/2HL\1/4\H1100
5400080	SCRN\DUMMY\1/4\H1100
5400050	SCRN\2HL\1/4\H1100
5400107	SCRN\GRDR\H1100\SOLID

ROTOR ASSEMBLY - SN II0185 AND UP

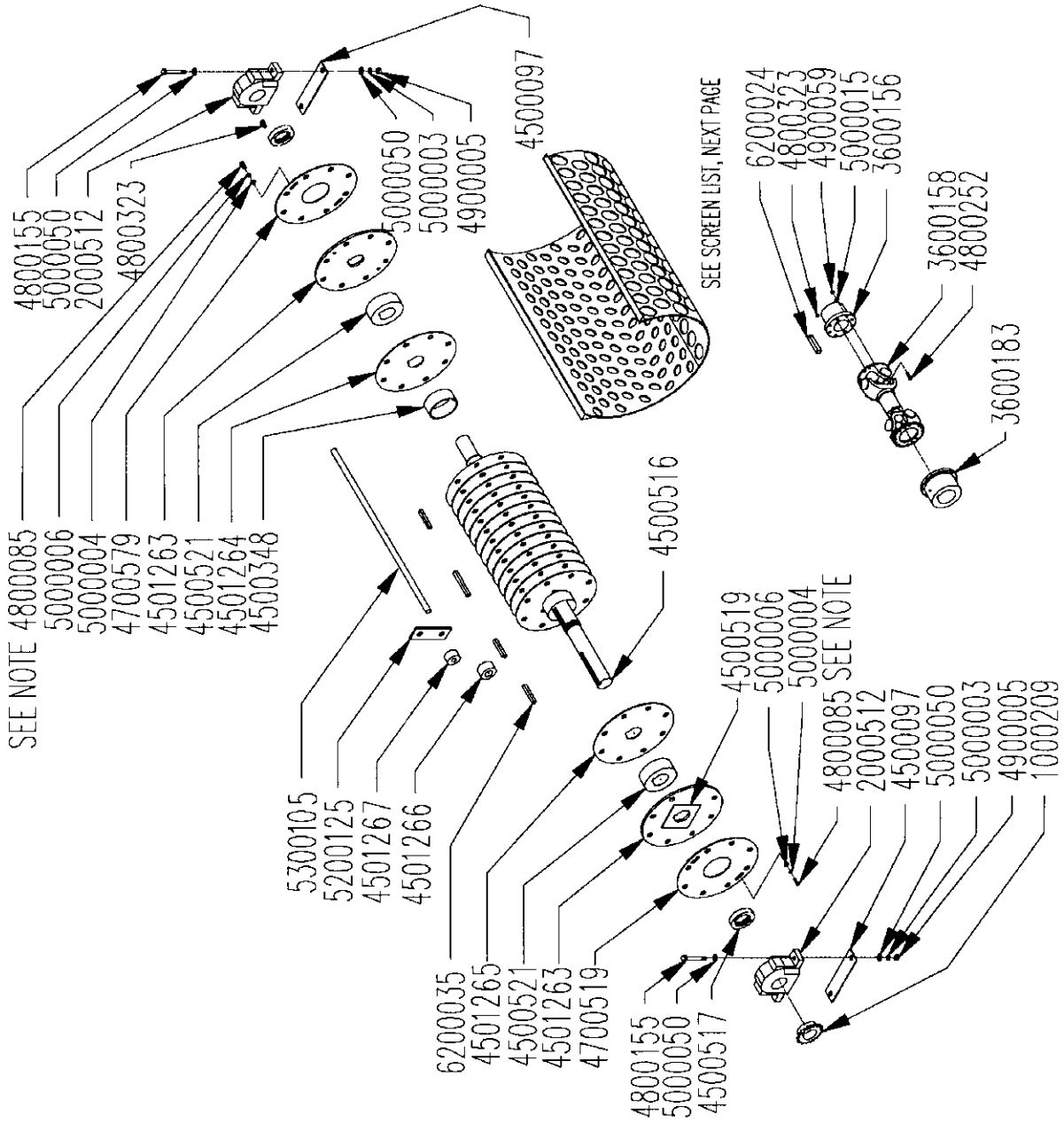



**ROTOR ASSEMBLY - SN 110185 AND UP**

<b>PART</b>	<b>QTY.</b>	<b>PART DESCRIPTION</b>
4501283		ROTOR\SUB ASSEMBLY
4501284		ROTOR\NEW\50X1.25\ROD\W\PLATES
4501295		RTR\RBLT\50X1.25\RD\H1100E
4501296		RTR\CORE\50X1.25\RD\H1100E
1000209	1	SPKT\60\20\2SS\NO;KW
2000512	2	BRG\PB3
3600156	1	FLANGE 3" ID 1710
3600158	1	1710 DRIVE LINE 18" COMP.
3600183		FLG\3-1/2\DX4L\1710\DRLIN
4500097	4	SHIM\BRG\3/16X3X11-3/4
4500348	16	1.878 CYLINDER SPACER
4500516	1	4-1/2" CYLINDER SHAFT
4500517	2	CYLINDER NUT 4-1/2" SHAFT
4500519	2	4-1/2" THRUST WASHER
4500521	6	SOLID CYLINDER SPACER
4501263	2	PL\RTR\END\TPPD\4.5\DX1/2
4501264	16	PL\RTR\GRV\4.5X1/2X15.75
4501265	5	PL\RTR\4.5X1/2X15.75
4501266	88	SPCR\SHOCK\2.5X1.27X1.5L
4501267	48	SPCR\HMMR\2.5X1.27X.625L
4700519	2	PL\RTR\MVBL\8.030\DX1/4
4800085	4	BOLT\HEX\1/2X1
4800155	4	BOLT\HEX\5/8X7
4800252	16	BOLT\7/16X1-3/8\GR8
4800323	2	SCR\SET\ALN\1/2X1\NC
4800326	16	SCR\SET\ALN\1/2X1/2\NC
4900005	4	NUT\HEX\5/8\NC
4900059	16	NUT\HEX\7/16\NF
5000003	4	WASH\LOCK\5/8
5000004	4	WASH\FLAT\1/2
5000006	4	WASH\LOCK\1/2
5000015	16	WASH\LOCK\7/16
5000050	8	WASH\FLAT\11/16\2"ODX1/4T
5200125	88	HMMR\SWING\1/2X3/2-HOLE\1-1/4
5300105	8	ROD\HMMR\1-1/4X50\IND
6200024	1	KEY\SQ\3/4X4
6200035	4	KEY\RECT\1/2X5/8X6-1/4

**NOTE: #4800085 MUST HAVE HEAD MACHINED OFF TO 1/2 THE ORIGINAL THICKNESS.**

**SCREEN LIST - all screens 1/4" thick**

<b>PART</b>	<b>DESCRIPTION</b>
5400091	SCRN\2HL\1/4\SLTD\H1100
5400095	SCRN\1/8HL\1/4H1100
5400051	SCRN\3HL\1/4H1100
5400074	SCRN\3/16HL\1/4H1100
5400090	SCRN\3HL\1/4\SLTD\H1100
5400052	SCRN\1/4HL\1/4H1100
5400062	SCRN\4HL\1/4H1100
5400053	SCRN\3/8HL\1/4H1100
5400092	SCRN\4HL\1/4\SLTD\H1100
5400054	SCRN\1/2HL\1/4H1100
5400102	SCRN\5HL\1/4
5400055	SCRN\5/8HL\1/4H1100
5400110	SCRN\6HL\1/4H1100E
5400056	SCRN\3/4HL\1/4H1100
5400111	SCRN\7HL\1/4H1100E
5400049	SCRN\1HL\1/4H1100
5400103	"8" SCREEN\1/4 HR PLATE"
5400066	SCRN\1 1/2HL\1/4H1100
5400080	SCRN\DUMMY\1/4H1100
5400050	SCRN\2HL\1/4H1100
5400107	SCRN\GRDR\H1100\SOLID

**CONTROL PANEL ASSEMBLY FOR SN GI0140 - HI0184**

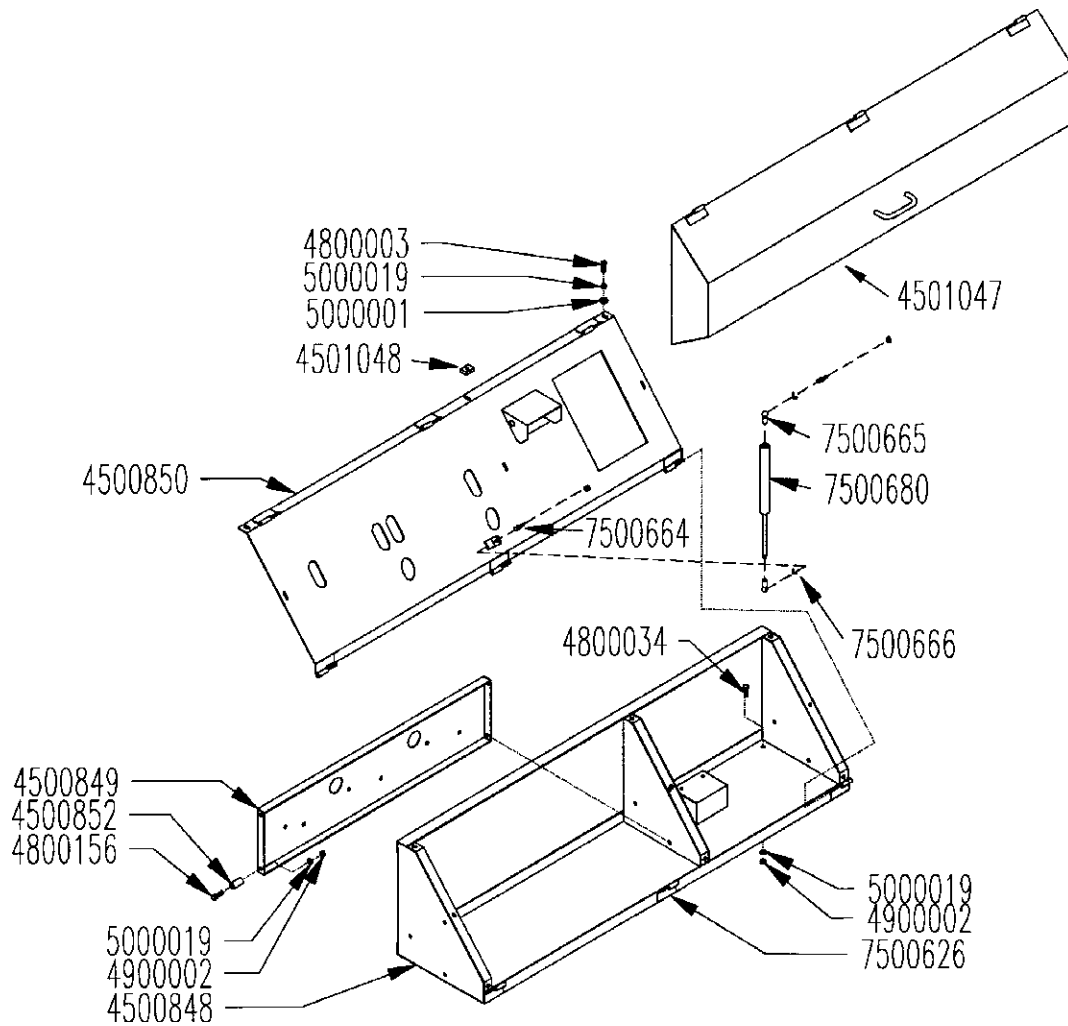

PART	QTY.	PART DESCRIPTION
4500851		PANEL\CONTROL\SUB ASSEMBLY
4500848	1	ENCL\CNTRL\PANEL
4500849	1	BRKT\VLV\PANEL\CNTRL
4500850	1	CVR\PANEL\CNTRL\ENGINE
4500852	4	BUSH\MTH\BRKT\CNTRL
4501047	1	CVR\PANEL\CONTROL\H1100E
4501048	1	PL\STOP\CVR\PANEL\CONTROL
4800003	6	BOLT\HEX\3/8X1
4800034	4	BOLT\HEX\3/8X1-1/2
4800156	4	BOLT\HEX\3/8X3
4900002	8	NUT\HEX\3/8\NC
5000001	6	NUT\FLAT\3/8
5000019	14	WASH\LOCK\3/8
7500626	3 PR	HINGE\SURFACE\3\LH
7500664	2	SHOCK\BALL\FITTING
7500665	2	SHOCK\END\FITTING
7500666	2	SHOCK\SAFETY\CLIP
7500680	1	SPRING\GAS\60LB

**CONTROL PANEL ASSEMBLY FOR SN HI0165 AND UP**

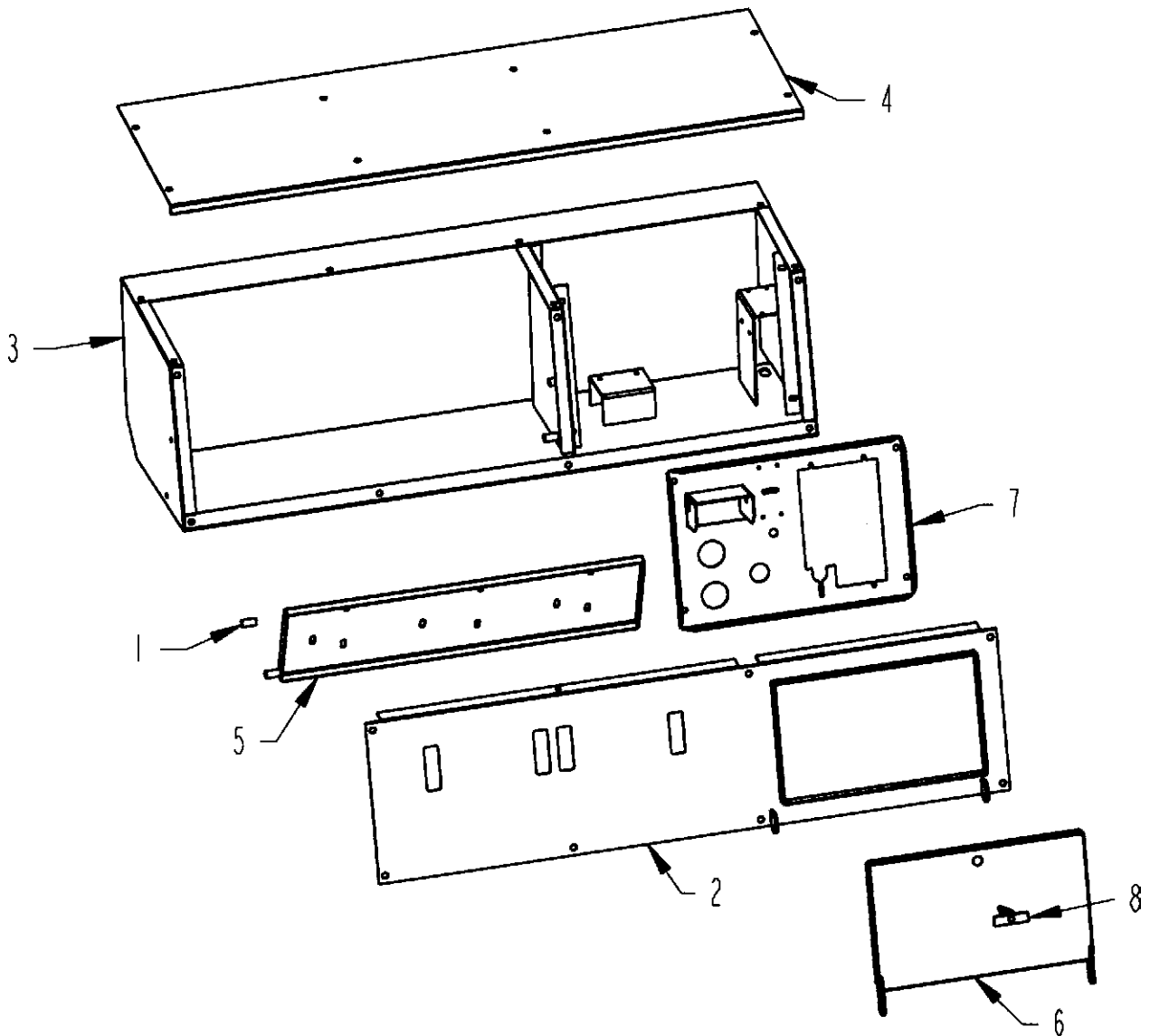

ITEM	PART	QTY.	PART DESCRIPTION
1	4500852	4	BUSH\MTG\BRKT\VCNTRL
2	4501107	1	COV\FRONT\PNL\CNTRL
3	4501108	1	FRM\PNL\CNTRL
4	4501109	1	CVR\PNL\CNTRL
5	4501110	1	BRKT\VLV\PNL\CNTRI
6	4501111	1	DOOR\CNTRL\ENG
7	4501112	1	BRKT\CNTRL\ENG
8	7500667	1	LATCH\COMP\DOOR\ACCESS\WIKEYS

**CLUTCH LINKAGE FOR SN HI0165 AND UP**

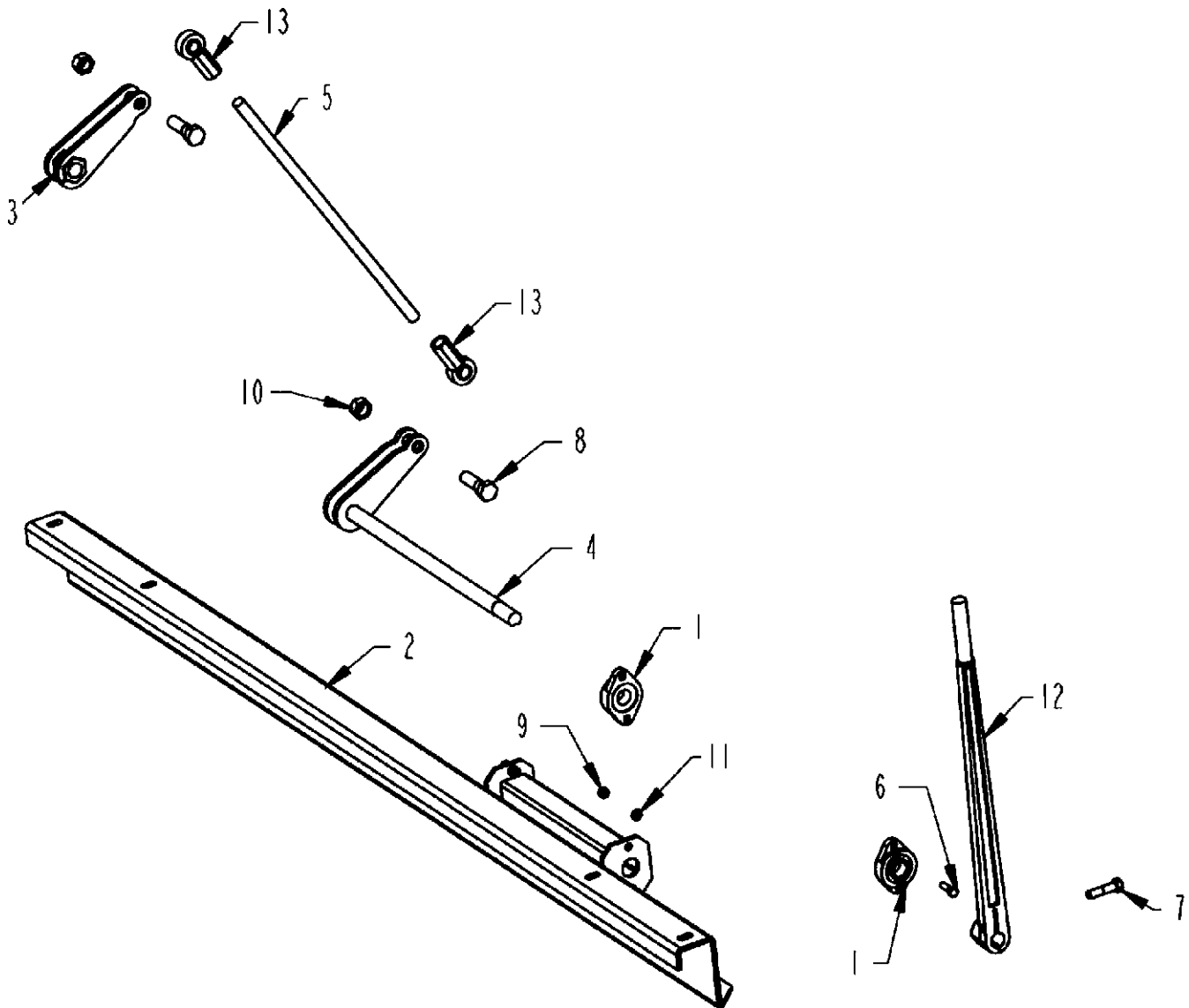

ITEM	PART	QTY.	PART DESCRIPTION
1	2000310	2	BRG\FLG\CAST\1/2-BOLT
2			MAIN FRAME
3	4501125		ARM\CNTRL\CLUTCH\UPPER
4	4501123		SHFT\ARM\LEVER\CLUTCH
5	4501124		ROD\ADJ\LEVER\CLUTCH
6	4800098	2	BOLT\HEX\3/8X1-1-1/4\NC
7	4800114	1	BOLT\HEX\1/2X2
8	4800115	2	BOLT\HEX\3/4X2-1/2\NC
9	4900002	2	NUT\HEX\3/8\NC
10	4900106	2	NUT\NYLCK\3/4\NC
11	5000019	4	WASH\LOCK\3/8
12	7500691	1	LVR\CLUTCH\3/4\TD
13	7500710	2	ROD\END

## GOVERNOR ASSEMBLY

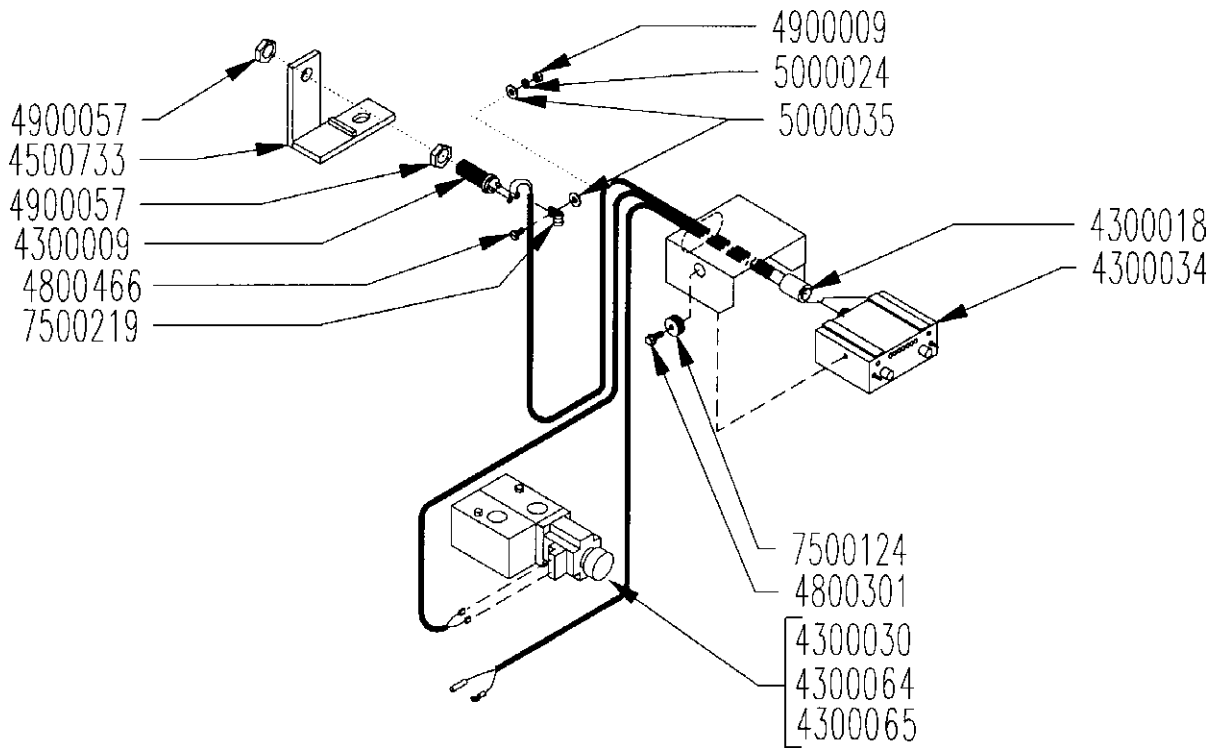

PART	QTY.	PART DESCRIPTION
4500903		GOVERNOR SUB ASSEMBLY
4300009	1	SENSOR\MAG\W\HARDWARE
4300018	1	WIRING HARNESS
4300030	1	HYD. ELECTRIC SOLENOID VALVE COMPLETE (CV93) 12V 20GPM, see page 97 ORDER 4300065
4300064	1	HYD. ELECTRIC SOLENOID VALVE COMPLETE (CV93) 24V 20GPM, see page 97 ORDER 4300064
4300034	1	NEW STYLE CONTROL BOX
4300054		Solenoid\Hyd Valve\24V, for 4300053 and 4300064
4300064		VALVE\SERVO\15GPM\24VDC see page 97
4300065		VALVE\SERVO\15GPM\12VDC see page 97
4500733	1	BRKT\SNSR\SHAFT\RTR for SN up to HI0164
4800154	1	SCR\RD\SLOT\1/4X1/2\NC
4800301	2	SCR\FLG\SERR\1/4X1/2\NC
4900009	1	NUT\HEX\1/4\NC
4900057	2	NUT\JAM\3/4\NF
5000024	1	WASH\LOCK\1/4
5000035	2	WASH\FLAT\1/4
7500124	2	GROMMET\RUBBER\2757
7500219	1	1/4" WIRE CLAMP

BELLY CONVEYOR ASSEMBLY

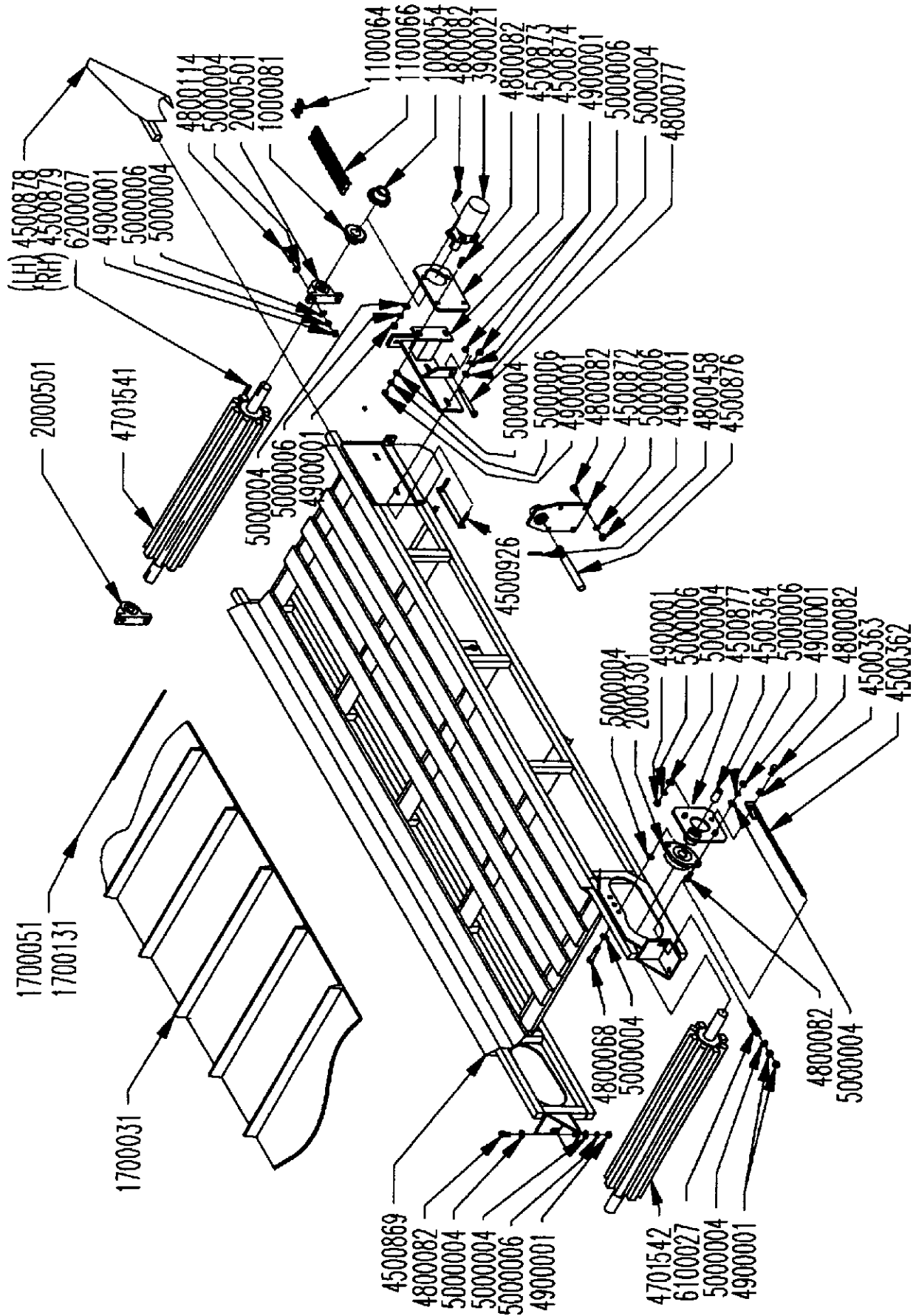

**BELLY CONVEYOR ASSEMBLY**

<b>PART</b>	<b>QTY.</b>	<b>PART DESCRIPTION</b>
4500702		BELLY CONVEYOR SUB ASSEMBLY
1000054	1	SPKT\60\18\1-1/4\5\16KW
1000081	1	SPKT\60\18\1-1/2\3\8KW
1100064	1	CHAIN\60DBL\CL
1100066	1	CHAIN-60\DBL\17
1700031	1	BELT\BELLY;PAN\30X18'
1700158		BELT\BELLY;PAN\30X18\3/4C R2 LACE
1700051	1	LCNG\CBL\3\16X30\NYL
1700131		LCNG\CBL\R-2\30\PURCH
2000301	2	BRG\FLB\CAST\1-1/4\2-BOLT
2000501	2	BRG\PB\1-1/2\2-BOLT
3900021	1	MTR\HYD\8\2000SERIES see page 96
4500362	2	TGHTNR\BELT\CNVYR\BELLY
4700525		ROD\ADJ\CONVY\BLLY
4500363	2	TUBE\RD\1X1/2X5/16
4500364	2	TUBE\RD\1X1/2X1-13/16"
4500869	1	FRAME\CNVYR\BLLY
4500871	1	RLLR\IDLER\CNVYR\BLLY\6X30
4500872	2	BRKT\MNT\CNVYR\BLLY\REAR
4500873	1	BRKT\MTR\ORBIT\CNVYR\BLLY
4500874	1	MNT\BRG\DRV\CNVYR\BLLY\LH
4500875	1	MNT\BRG\DRV\CNVYR\BLLY\RH
4500876	1	PIN\MNT\CNVYR\BLLY\REAR
4500877	2	BRKT\BRG\IDLER\CNVYR\BLLY
4500878	1	GUIDE\MATL\CNVYR\BLLY
4500879	1	GUIDE\MATL\CNVYR\BLLY
4500926	2	BRKT\TGHTNR\RLLR\CNVYR\BELLY
4701541	1	RLLR\DRIVE\39-3/4X6\CNVYR\ 1-1/2"SHAFT
4701542	1	RLLR\DRIVE\39X6\CNVYR\BEL\1-1/4 SHAFT
4800068	2	BOLT\HEX\1/2X3
4800082	16	BOLT\HEX\1/2X1-1/2
4800114	4	BOLT\HEX\1/2X2
4800458	1	PIN\RLLD\3/8x1-3/4
4900001	31	NUT\HEX\1/32\NC
4900072	2	NUT\HEX\#10\NC
5000004	31	WASH\FLAT\1/2
5000006	23	WASH\LOCK\1/2
6100027	2	SPRING\COMPRESSION
6200007	1	KEY\SQ\3/8X1-1/2
<b>NOT SHOWN</b>		
1700053		LCNG\FSTNR\187W\STPL\30
1700130		LCNG\R-2\30\PURCH
1700132	34	LCNG\RIVET\R-2\PURCH
1700129		LCNG\TOOL\R-2\SNGL\INCLUDED IN 1700137
1700137		LCNG\TOOL\R-2\41213\APP

**LOWER DISCHARGE CONVEYOR - 26FT.  
FOR SN GI0140 TO H10184**

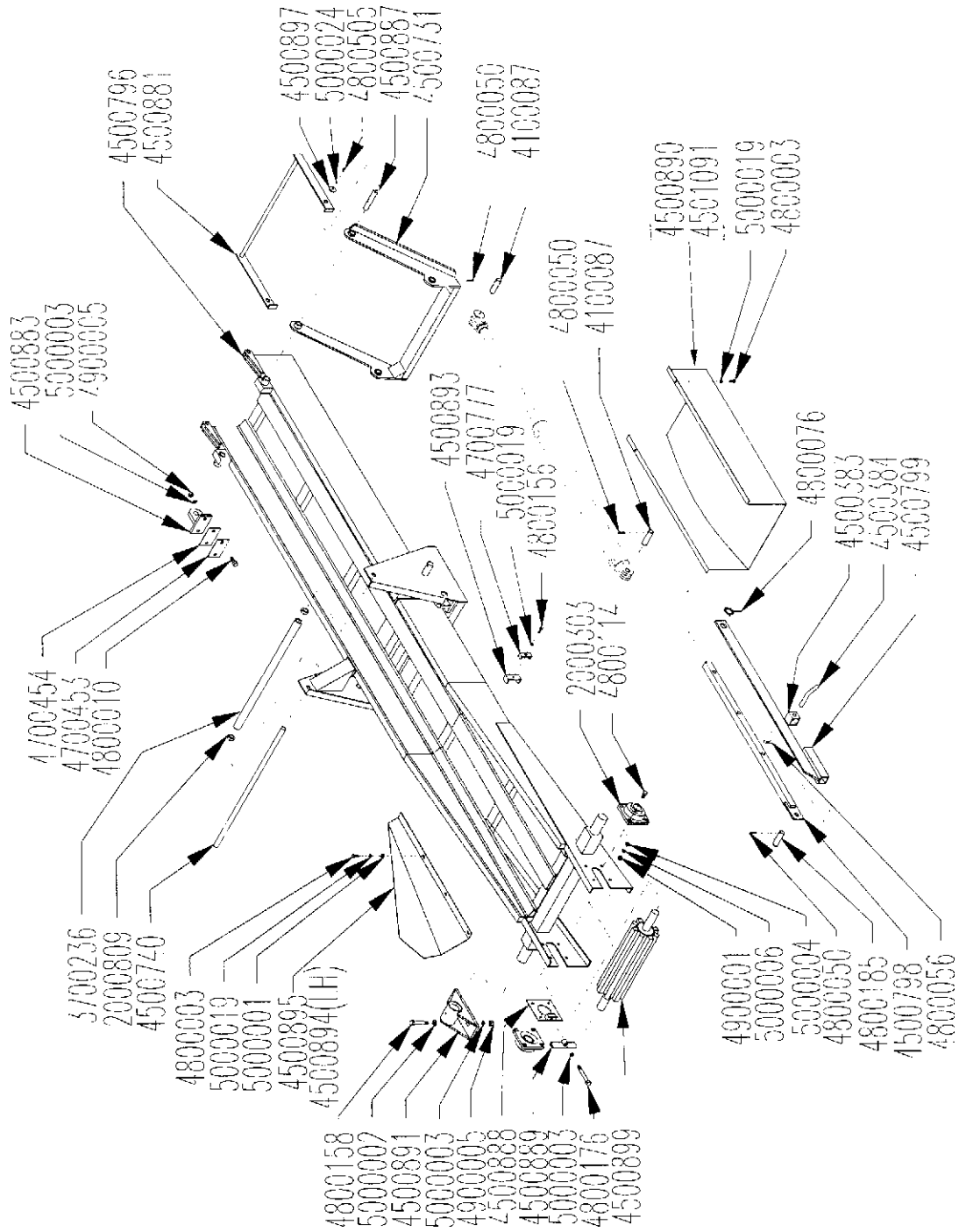



**LOWER DISCHARGE CONVEYOR - 26 FT.  
FOR SN GI0140 TO HIO184**

<b>PART</b>	<b>QTY.</b>	<b>PART DESCRIPTION</b>
2000303	2	BRG\FLG\1-1/2\4-BOLT
2000809	2	CLLR\SHAFT\1\SET
3700236	1	HOSE\HYD\1X31
4100087	10	1X3-1/2 CYL PIN STD.
4500383	2	LATCH\CNVYR\SAFETY
4500384	2	PIN\CNVYR\SAFETY;BAR
4500731	1	ARM\CNTRL\CNVYR\FOLD
4500740	1	SHAFT\SUPPORT\LOW;DISCHARGE
4500796	1	FRM\CNVYR\DISCH\LOWER
4500798	2	BRKT\CNVYR\SAFETY;BAR
4500799	2	GUIDE\CNVYR\SAFETY;BAR
4500881	1	TGHTNER\BELT\CNVYR
4500883	2	ANCHOR\CYL\HYD
4500887	2	PIN\CNVYR\ARM\CNTRL
4500888	1	BRKT\ADJ\TRCKG\CNVYR\DISCH
4500889	1	HOOK\ROD\TGHTR\BELT\CNVYR
4500890	1	GUIDE\CNVYR\BELT\BTM
4500891	2	MNT\CNVYR\FRM\MN
4700077	3	CLAMP\HOSE\CNVYR\DISCH
4500893	4	CLAMP\HOSE\CNVYR\DISCH
4500894	1	GUIDE\MATL\CNVYR\DISCH\LH
4500895	1	GUIDE\MATL\CNVYR\DISCH\RH
4500897	2	RETAINER\GUIDE\BELT\SLUG
4500899	1	RLLR\IDLER\CNVYR\DISCH
4700453	2	14 GA HYD CYL SHIM
4700454	2	10 GA HYD CYL SHIM
4800003	10	BOLT\HEX=3\8X1
4800010	4	BOLT\HEX\5\8X2
4800050	24	PIN\COT\3\16X1-1/2
4800056	2	PIN\HAIR\3\16X3 (#6)
4800076	2	PIN\KLIK\5\16
4800100	1	BOLT\HEX\5\8X4
4800114	8	BOLT\HEX\1\2X2
4800156	4	BOLT\HEX\3\8X3
4800158	4	BOLT\HEX\5\8X4-1/2
4800185	2	PIN\CLEVIS\1X3
4800505	2	BOLT\HEX\1\4X1-1/2\NC
4900001	8	NUT\HEX\1\2\NC
4900005	8	NUT\HEX\5\8\NC
5000001	6	WASH\FLAT\3\8
5000002	4	WASH\FLAT\5\8
5000003	9	WASH\LOCK\5\8
5000004	8	WASH\FLAT\1\2
5000006	8	WASH\LOCK\1\2
5000019	14	WASH\LOCK\3\8
5000024	2	WASH\LOCK\1\4

**LOWER DISCHARGE CONVEYOR - 26 FT.  
FOR SN HI0185 AND UP**

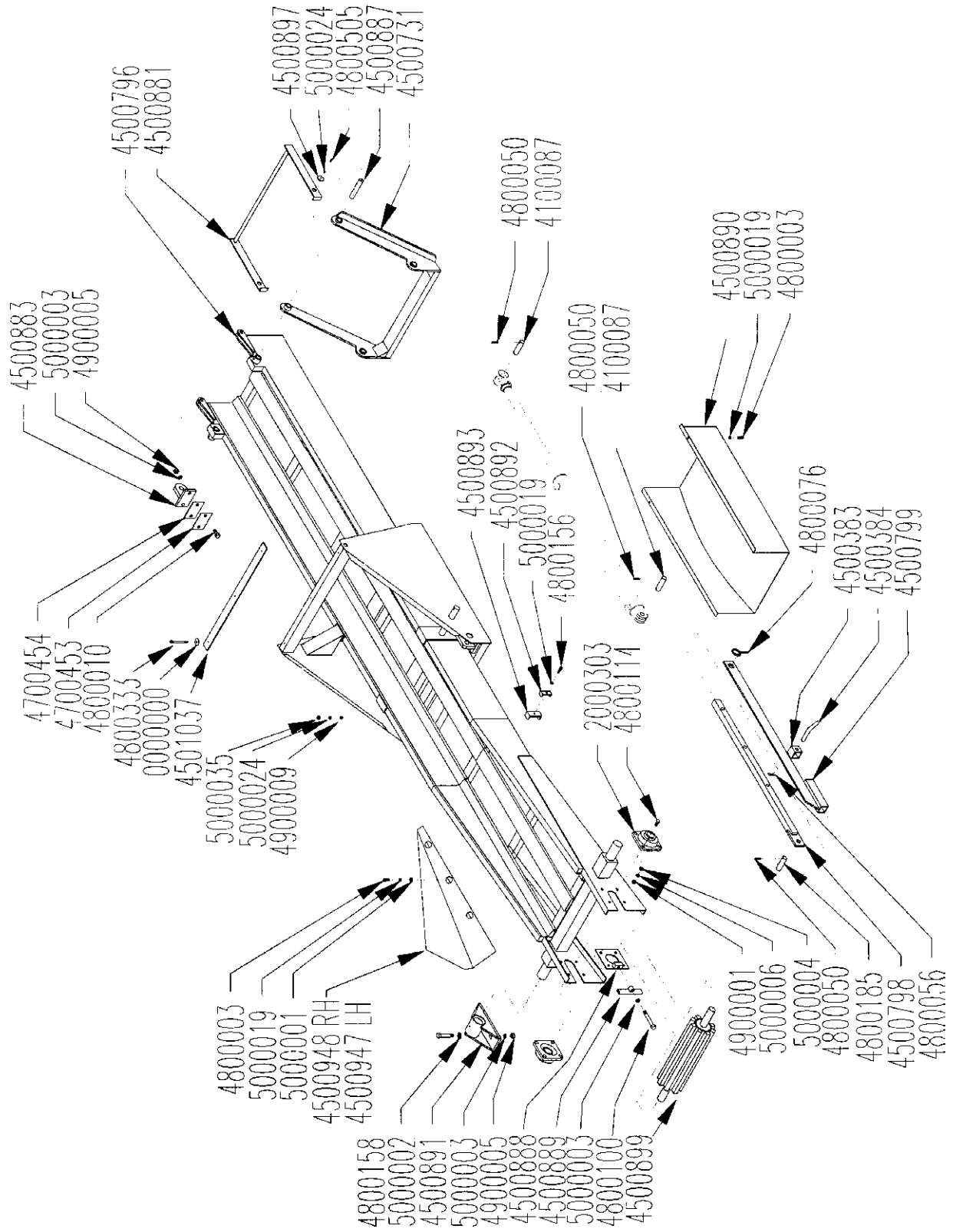

**LOWER DISCHARGE CONVEYOR - 26 FT.  
FOR SN HI0185 AND UP**

<b>PART</b>	<b>QTY.</b>	<b>PART DESCRIPTION</b>
4500917		LOWER DISCHARGE CONVEYOR SUB
2000303	2	BRG\FLG\1-1/2\4-BOLT
4100087	10	1X3-1/2 CYL PIN STD.
4500383	2	LATCH\CNVYR\SAFETY
4500384	2	PIN\CNVYR\SAFETY;BAR
4500731	1	ARM\CNTRL\CNVYR\FOLD
4500796	1	FRM\CNVYR\DISCH\LOWER
4500798	2	BRKT\CNVYR\SAFETY;BAR
4500799	2	GUIDE\CNVYR\SAFETY;BAR
4500881	1	TGHTNER\BELT\CNVYR
4500883	2	ANCHOR\CYL\HYD
4500887	2	PIN\CNVYR\ARM\CNTRL
4500888	1	BRKT\ADJ\TRCKG\CNVYR\DISCH
4500889	1	HOOK\ROD\TGHTR\BELT\CNVYR
4500890		GUIDE\CNVYR\BELT\BTM
4500891	2	MNT\CNVYR\FRMMN
4500892	3	CLAMP\HOSE\CNVYR\DISCH
4500893	4	CLAMP\HOSE\CNVYR\DISCH
4500947	1	GUIDE\MATL\CNVYR\DISCH\LH
4500948	1	GUIDE\MATL\CNVYR\DISCH\RH
4500897	2	RETAINER\GUIDE\BELT\SLUG
4500899	1	RLLR\IDLER\CNVYR\DISCH
4501036	1	TUBE\CROSS\REST\CNVYR\DIS
4501037	1	CUSHR\BBR\CNVYR\DIS\LOW
4501091	1	GUIDE\ BELT\CNVYR \LOWER
4700453	2	14 GA HYD CYL SHIM
4700454	2	10 GA HYD CYL SHIM
4800003	10	BOLT\HEX=3\8X1
4800010	4	BOLT\HEX\5\8X2
4800050	24	PIN\COT\3\16X1-1/2
4800056	2	PIN\HAIR\3\16X3 (#6)
4800076	2	PIN\LIK\5\16
4800114	8	BOLT\HEX\1\2X2
4800156	4	BOLT\HEX\3\8X3
4800158	4	BOLT\HEX\5\8X4-1/2
4800176	1	BOLT\HEX\5\8X4\FULL THREAD
4800185	2	PIN\CLEVIS\1X3
4800333	3	BOLT\HEX\1\4X4
4800505	2	BOLT\HEX\1\4X1-1\2\NC
4900001	8	NUT\HEX\1\2\NC
4900005	8	NUT\HEX\5\8\NC
4900009	3	NUT\HEX\1\4
5000001	6	WASH\FLAT\3\8
5000002	4	WASH\FLAT\5\8
5000003	9	WASH\LOCK\5\8
5000004	8	WASH\FLAT\1\2
5000006	8	WASH\LOCK\1\2
5000019	14	WASH\LOCK\3\8
5000024	5	WASH\LOCK\1\4
5000035	3	WASH\FLAT\1\4

UPPER DISCHARGE CONVEYOR - 26 FT.

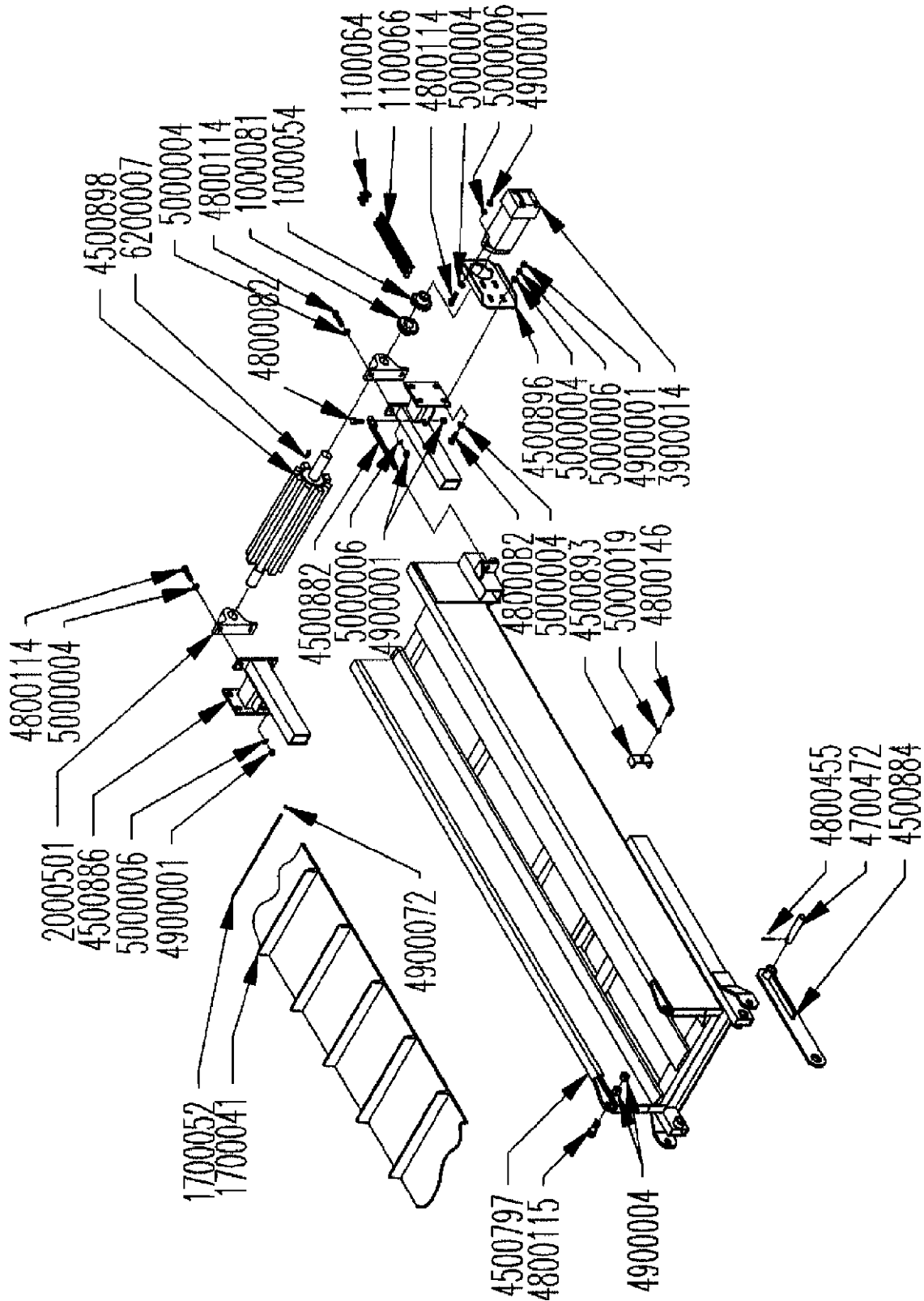

**UPPER DISCHARGE CONVEYOR - 26 FT.**

<b>PART</b>	<b>QTY.</b>	<b>PART DESCRIPTION</b>
4500918		UPPER DISCHARGE CONVEYOR
1000054	1	SPKT\60\18\1-1/4\5/16KW
1000081	1	SPKT\60\18\1-1/2\3/8KW
1100064	1	CHAIN\60DBL\CL
1100066	1	CHAIN\60DBL\17
1700041	1	BELT\CNVYR\18X52' (624")
1700052	1	LCNG\CBL\1/8X1\ANYL
2000501	2	BRG\PB\1-1/2\2-BOLT
3900014	1	MTR\HYD\9.6\2000\1-1/4SH see page 96
4500797	1	FRM\CNVYR\DISCH\UPPER\26'
4500882	2	ROD\ADJR\LLR\CNVYR\DISCH
4500884	2	LINK\LIFT\ARM\CNTRL
4500886	2	MNT\BRG\CNVYR\DISCH
4500893	3	CLAMP\HOSE\CNVYR\DISCH
4500896	1	MNT\MTR\ORBIT\CNVYR\DISCH
4500898	1	RLLR\DRIVE\CNVYR\DISCH
4700472	2	1X5.25\PIN CONT ARM MT
4800082	6	BOLT\HEX\1/2X1-1/2
4800114	6	BOLT\HEX\1/2X2
4800115	2	BOLT\HEX\3/4X2-1/2
4800146	3	BOLT\HEX\3/8X2
4800455	2	PIN\RLLD\1/4X1-1/2
4900001	10	NUT\HEX\1/2\NC
4900004	4	NUT\HEX\3/4\NC
4900072	2	NUT\HEX\#10\NC
5000004	14	WASH\FLAT\1/2
5000006	10	WASH\LOCK\1/2
5000019	3	WASH\LOCK\3/8
6200007	1	KEY\SQ\3/8X1-1/2
		<b>NOT SHOWN</b>
1700055		LCNG\ALGTR\#125\W\STPLS\18

# TUB ASSEMBLY

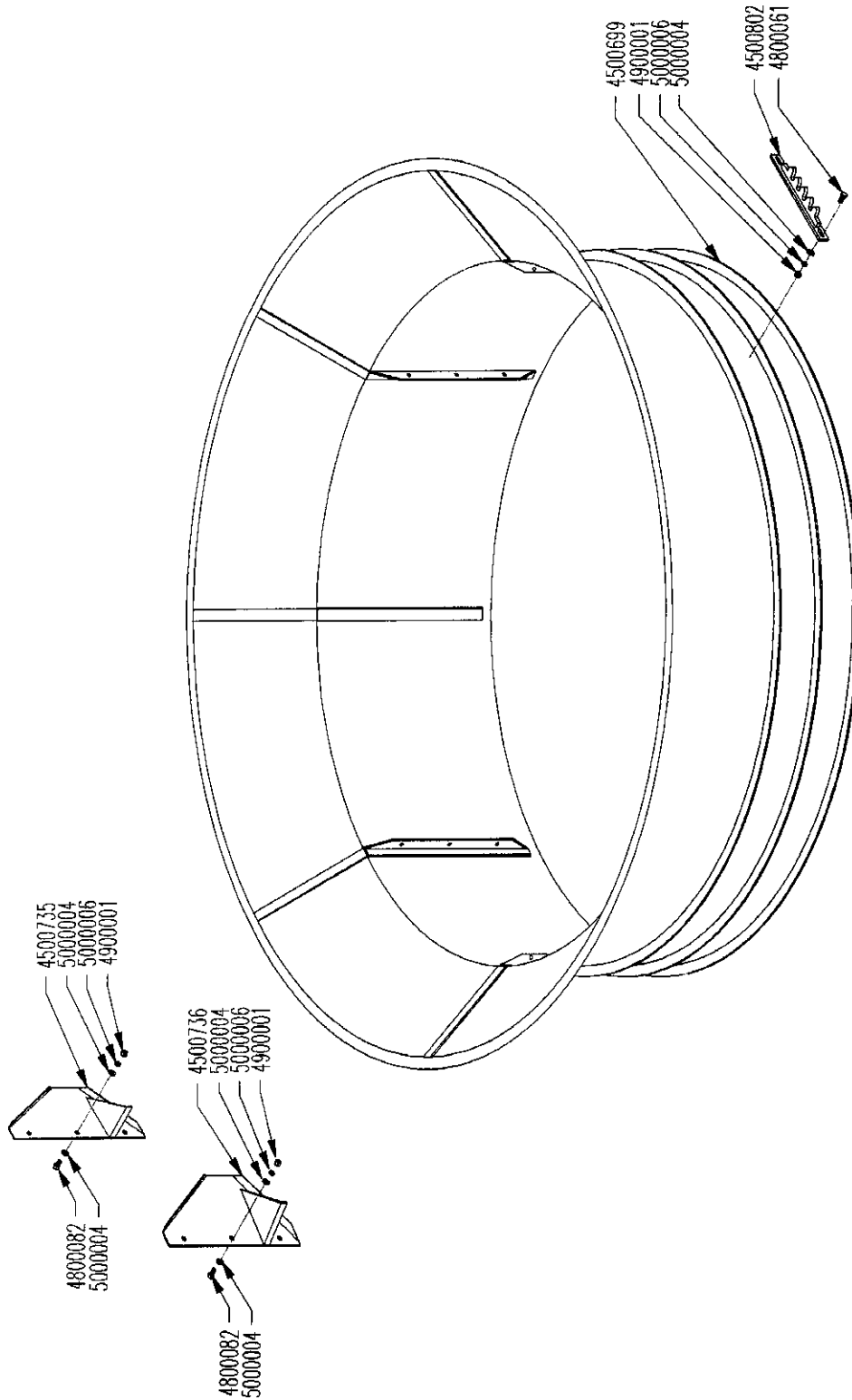

## TUB ASSEMBLY

<b>PART</b>	<b>QTY.</b>	<b>PART DESCRIPTION</b>
4500698		TUB SUB ASSEMBLY
4500699	1	TUBE\TUB\107.5X36
4500735	1	AGTTR\TUB\10"
4500736	1	AGTTR\TUB\14"
4500802	4	SPKT\TUB\KNOB
4800061	8	BOLT\CRG\1/2X1-1/2\NC
4800082	6	BOLT\HEX\1/2X1-1/2
4900001	14	NUT\HEX\1/2\NC
5000004	20	WASH\FLAT\1/2
5000006	14	WASH\LOCK\1/2
<b>Not Shown</b>		
4501355		SHIM\TUB\CHAIN\1/4X36

# ELECTRICAL ASSEMBLY

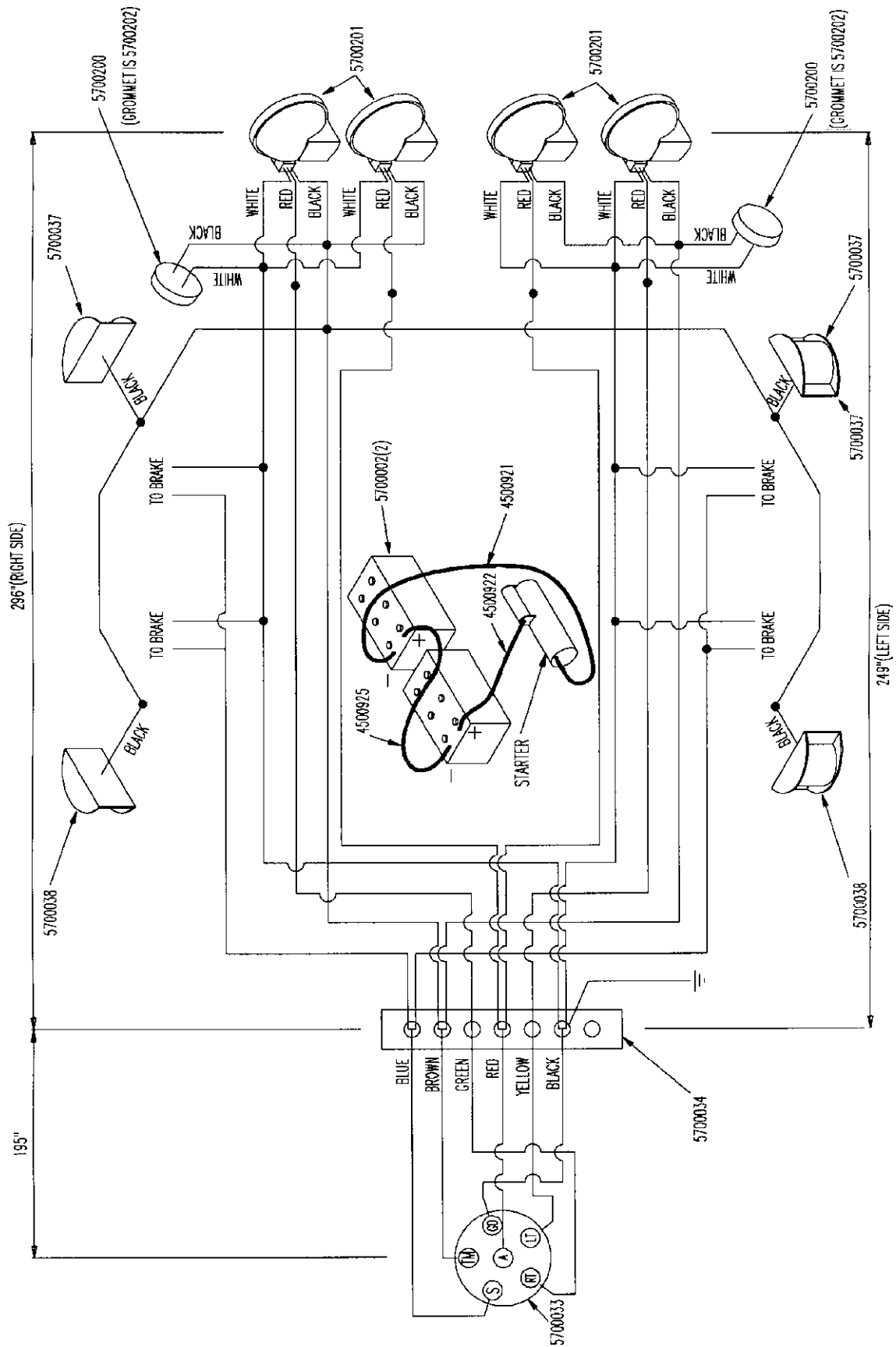



## ELECTRICAL ASSEMBLY

PART	QTY.	PART DESCRIPTION
4500916		ELEC\ASSY\SUB
4500921	1	CBL\BATT\2\0X122"\BLK
4500922	1	CBL\BATT\2\0X123"\RED
4500925	1	CBL\BARR\2\0X21"\BLK
5700002	2	BATT\12VDC\8D1150
5700008	73.33 FT	CBCORD\14 GA\6COND\FT
5700033	1	TERM \6POLE\TRLR\CONN
5700034	1	ENCL\JCT\7POLE\TRLR\HARN
5700037	2	LAMP\CL\12VDC\RED
5700038	2	LAMP\CL\12VDC\AMBER
5700047	18.17 FT	WIRE\STRAND\14 GA\BRN
5700200	2	LAMP\CL\12VDC\2-1/2 RD
5700201	4	LAMP\TAIL\4-1/2\COMP\RED
5700202	2	LAMP\GRMMT\2-1/2\KIT
4300018	1	WIRING HARNESS

# SCHEMATIC - MURPHY CONTROL PANEL - CAT ENGINE 24 VOLT ENGINE, 12 VOLT CONTROLS

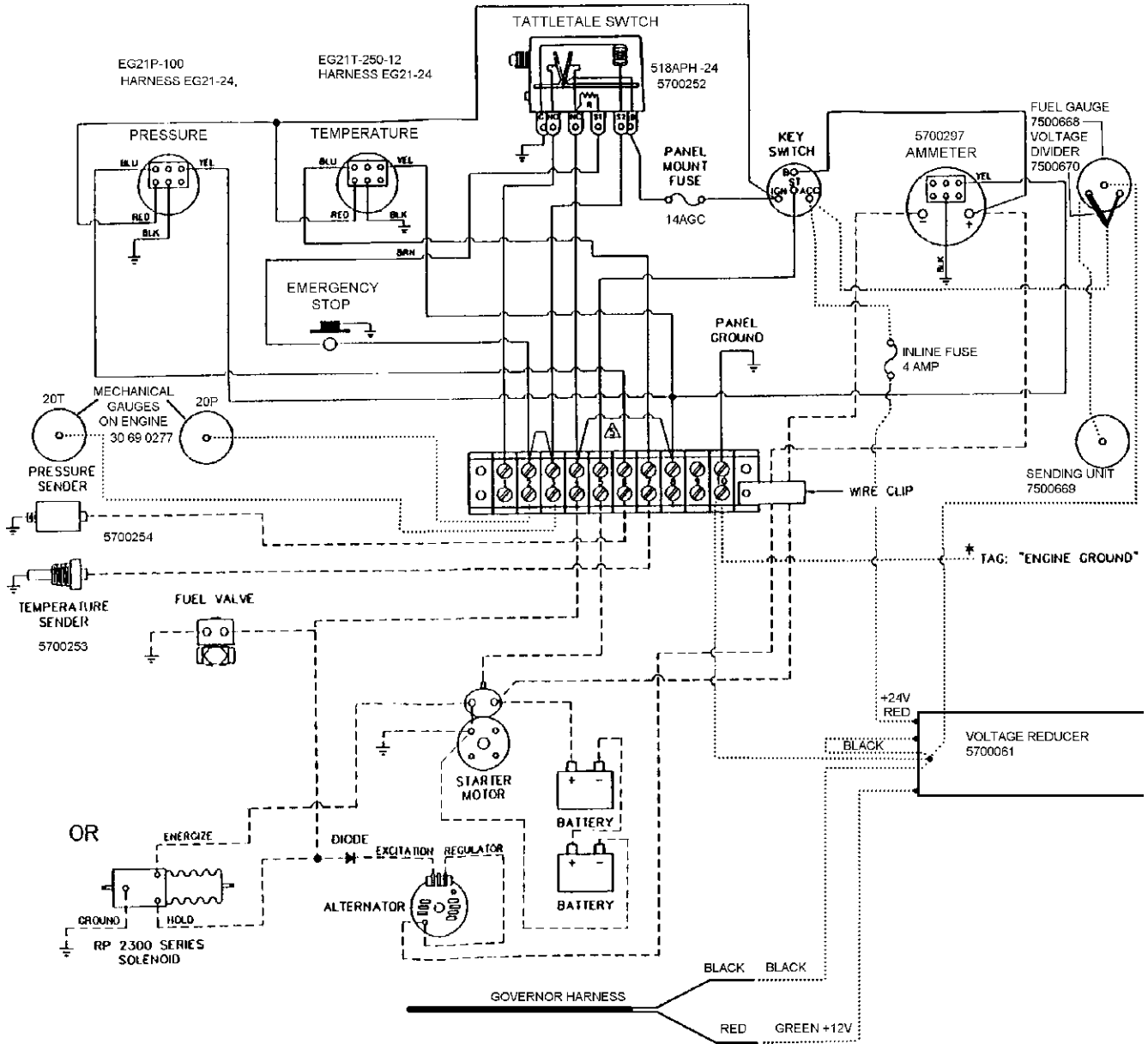

# SCHEMATIC - MURPHY CONTROL PANEL - CAT ENGINE 24 VOLT ENGINE AND CONTROLS

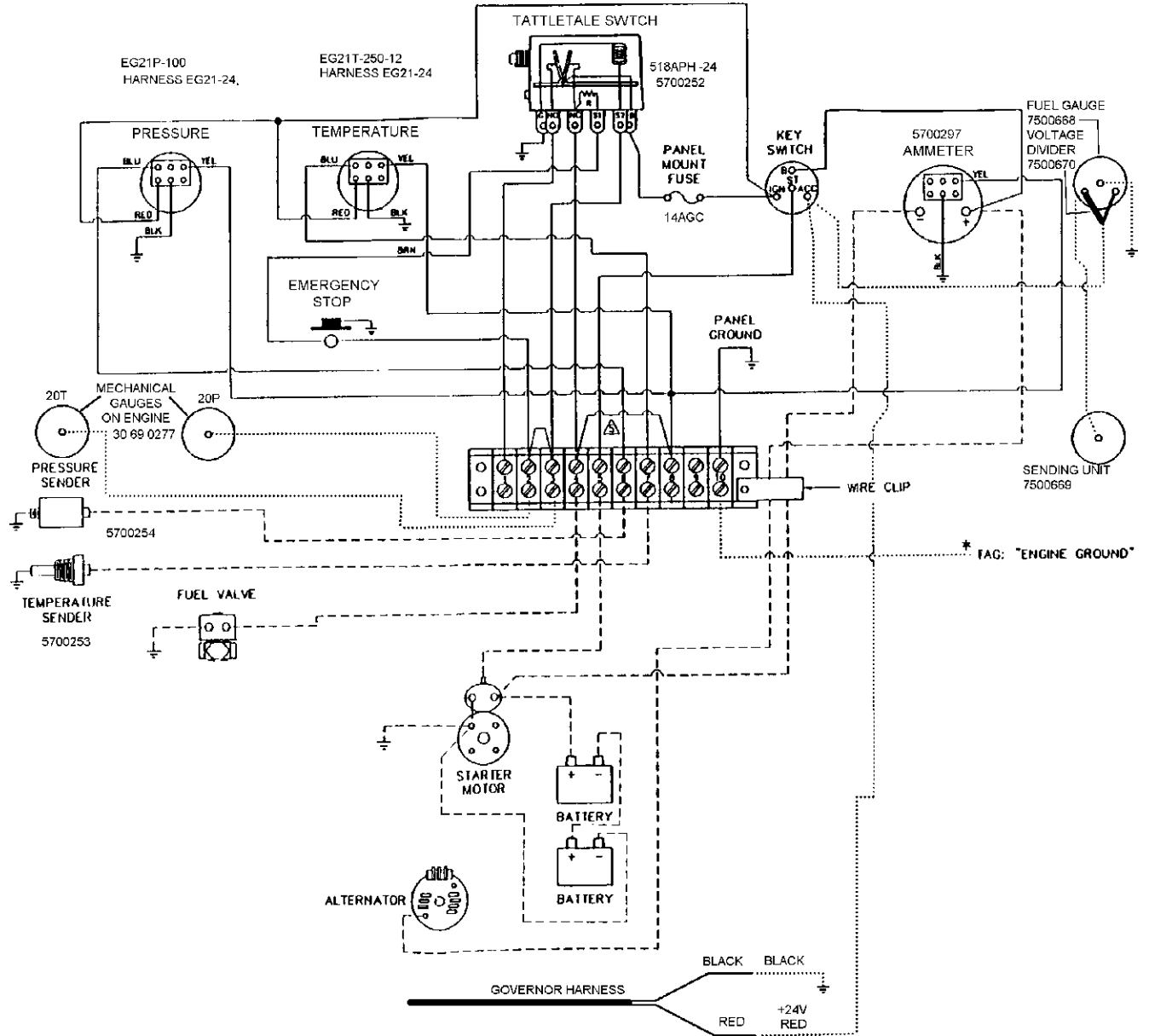

**SCHEMATIC - MURPHY CONTROL PANEL - CAT ENGINE  
24 VOLT SYSTEM WITH STARTER RELAY**

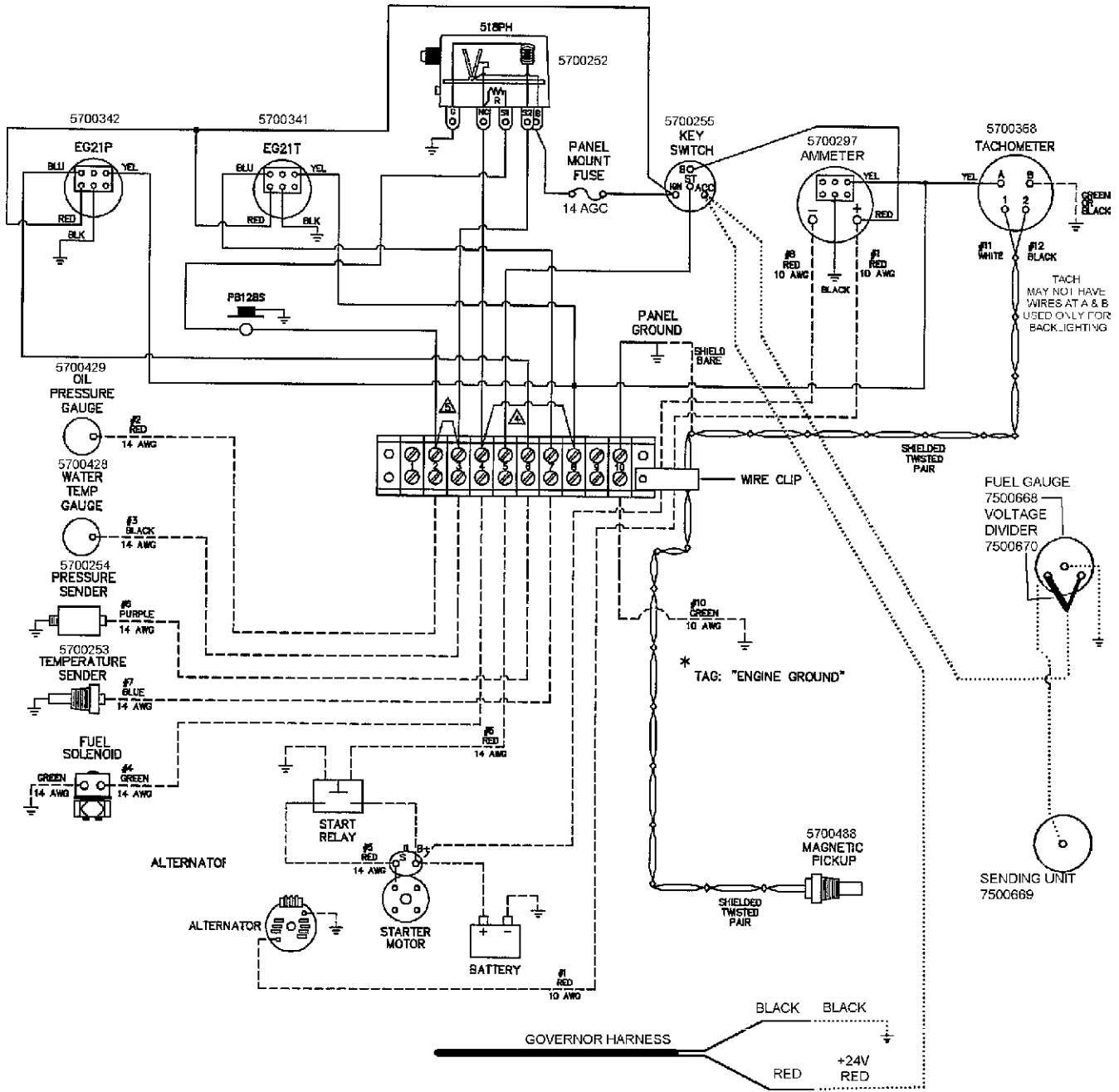

## MURPHY PANEL GAUGES

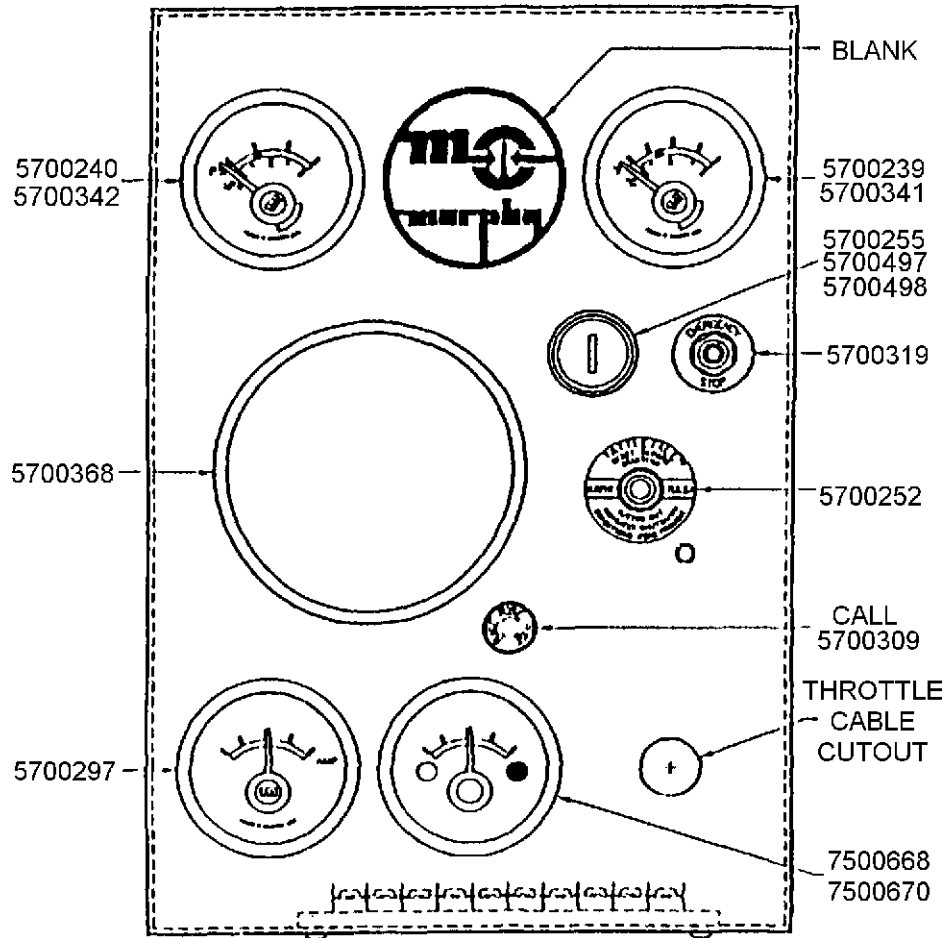

PART	QTY.	PART DESCRIPTION
5700061		VOLTAGE REDUCER (CAT ENGINE)
5700239	1	ELEC\GAUGE\TEMP\MURPHY
5700240	1	ELEC\GAUGE\OIL\MURPHY
5700252	1	ELEC\SWITCH\MAGNETIC\TAT
5700253		SENDING UNIT WATER TEMP
5700254		SENDING UNIT OIL PRESSURE
5700255		SWITCH\IGN\MRPH\SCREW TERM
5700297		GAUGE\AMP\CAT
5700309		FUSE\AGC-14
5700319		SWITCH\KILL\MURPHY\CAT
5700368		GAUGE\TACH\CAT\9X1117
5700497		SWITCH\IGN\CAT\SPADE;TERM
5700498		SWITCH\IGN\CAT\SCREW;TERM
7500668		GAUGE\FUEL\ELEC
7500669		GAUGE\FUEL\SENDING\UNIT
7500670		GAUGE\VOLTAGE\ADPT
7500304		THROTTLE CABLE CAT 48"
7500637		THROTTLE CABLE 10FT
7500674		THROTTLE CABLE CAT 80"
7500694		CBL\THRTL\5\25HP;ISUZU
7500702		CBL\THROTTLE\CUMN-14

**STANDARD WIRING SCHEMATIC- MACHINE &  
STANDARD WIRING SCHEMATIC MACHINE + LIGHT OPTION**

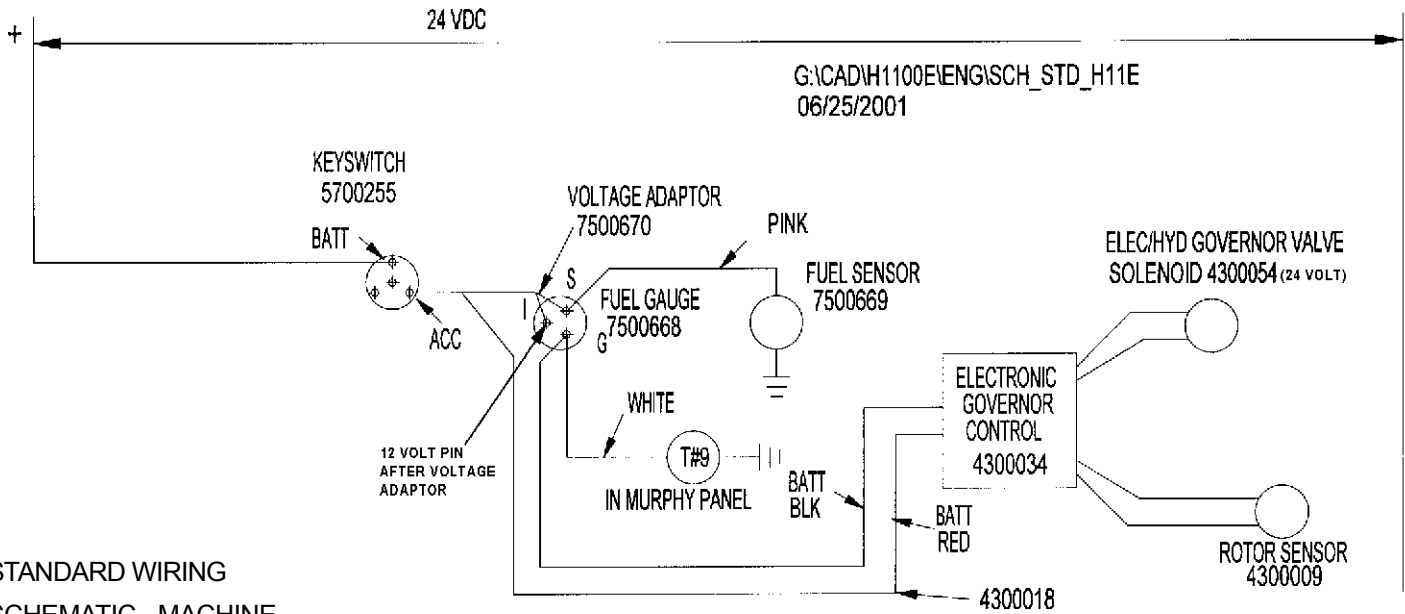

STANDARD WIRING  
SCHEMATIC - MACHINE

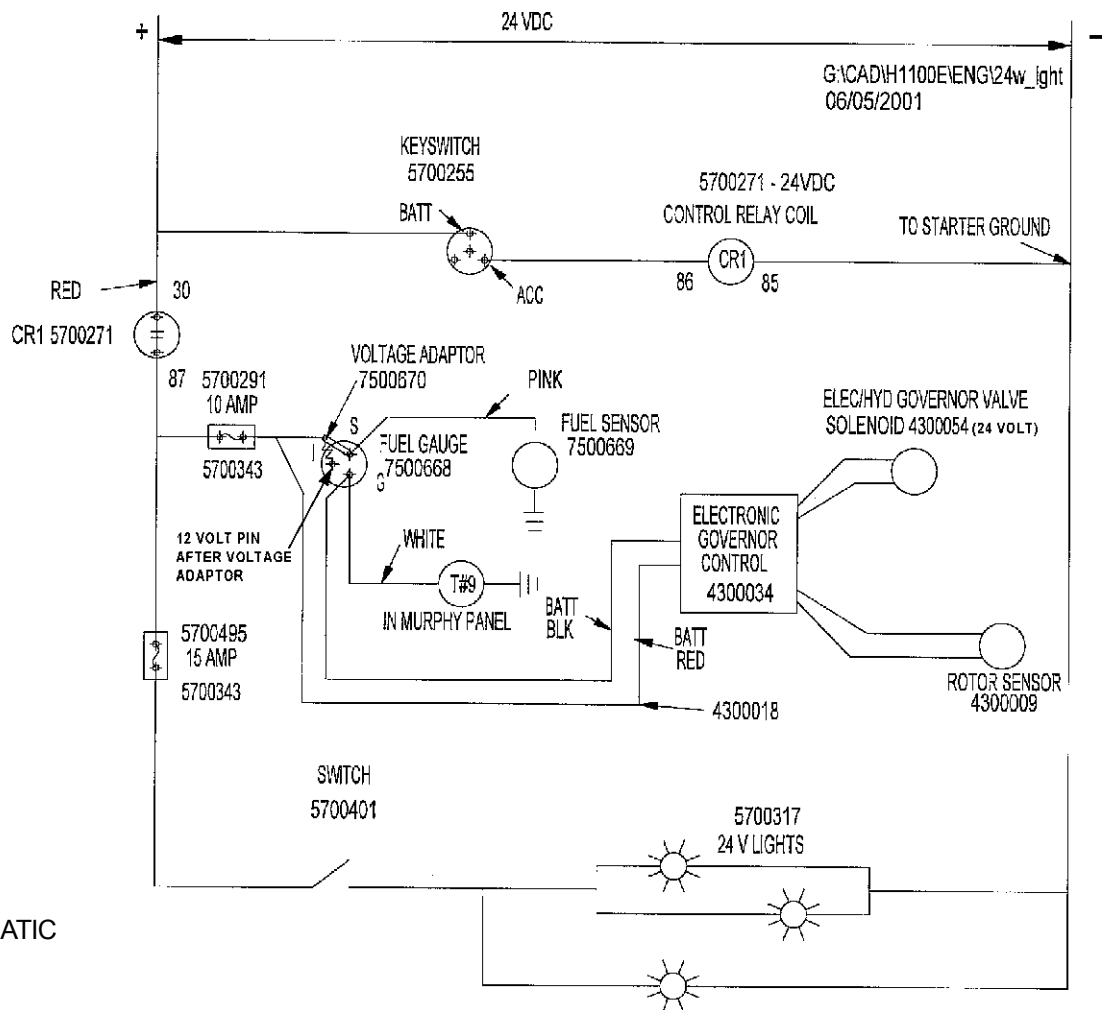

STANDARD WIRING SCHEMATIC  
MACHINE + LIGHT OPTION  
SN AJ0210 AND UP

**STANDARD WIRING SCHEMATIC- MACHINE &  
STANDARD WIRING SCHEMATIC MACHINE + LIGHT OPTION**

<b>PART</b>	<b>QTY.</b>	<b>PART DESCRIPTION</b>
4300009		SNSR\MAG\W\HDW
4300018		HARNESS\WIRING\IG-8
4300034		CNTRL BOX\NEW STYLE\RCB93
4300064		\SERVO\15GPM\24VDC\GOV\VALVE
5700255		IGNITION SWITCH CAT
5700271		RELAY\CONT:DUTY\24V
5700291		BRKR\CRCT\10A\AUTO\TYPE1\24V
5700317		LAMP\HALOGEN\4X6\24V
5700343		ENCL\BOOT\BRKR\CRCT\RED
5700401		SWITCH\TGGL\24V
5700495		BRKR\CRCT\15A\AUTO\TYPE1\24V
7500668		GAUGE\FUEL\ELEC
7500669		GAUGE\SENDING\UNIT
7500670		GAUGE\VOLTAGE\ADPT

## TUB ROLLER ASSEMBLY

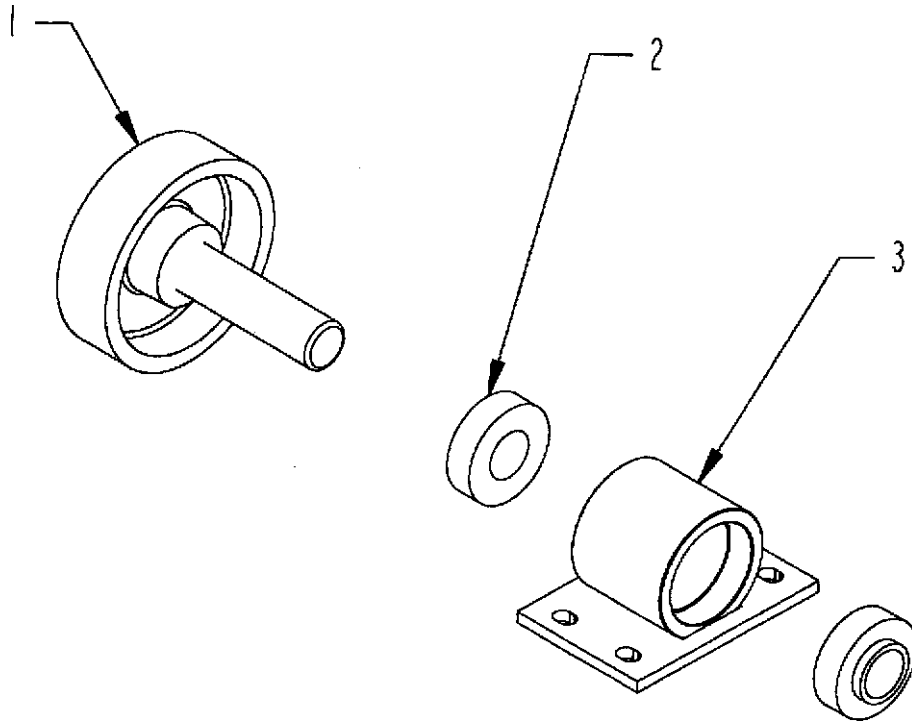

ITEM	PART	QTY.	PART DESCRIPTION
1	1200013	1	RLLR\TUB\1-1/2W/O;FLG
2	2000062	2	BRG\CYL\1-1/2W-ECC
3	4702007	1	BRG\PB\RLLR\TUB\ASYW\BEARING INSERTS



## PRESSURE ROLLER ASSEMBLY

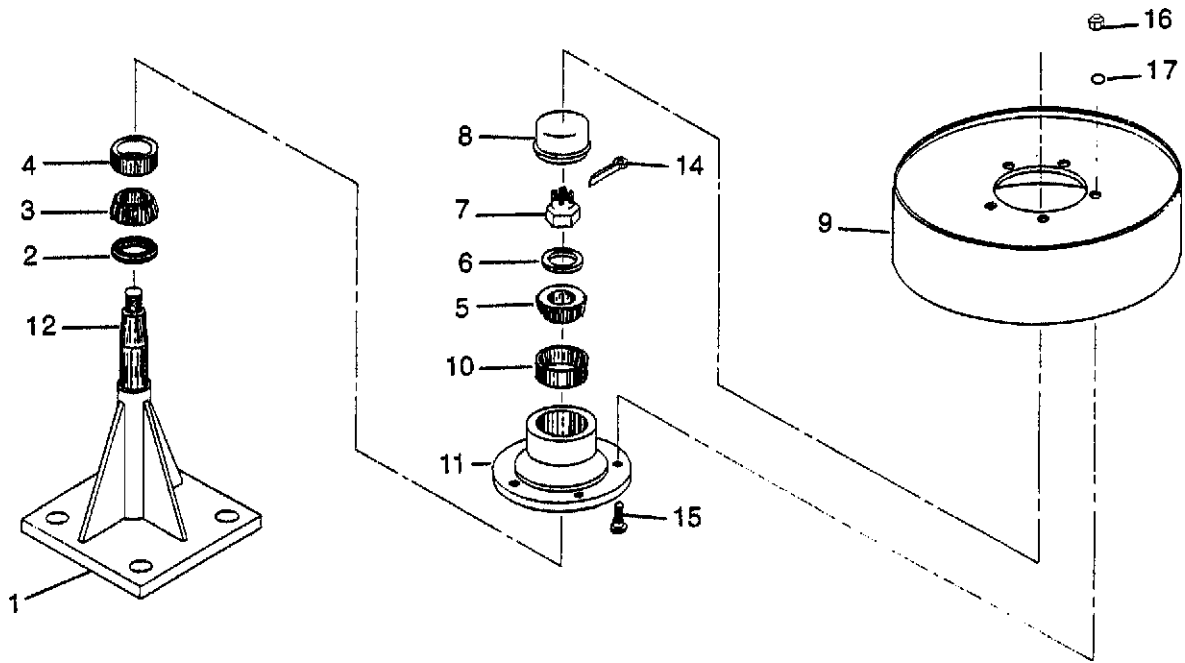

ITEM	PART	QTY.	PART DESCRIPTION
1	4501090	1	SINGLE STAND 10" SPINDLE
2	2900055	1	SEAL
3	2900018	1	INNER CONE
4	2900004	1	INNER CUP
5	2900061	1	OUTER CONE
6	5000094	1	5/8" WASHER\SPINDLE
7	4900112	1	NUT\SLOT\5/8\NF
8	2900064	1	DUST CAP
9	4500088	1	PRESSURE DRUM
10	2900056	1	OUTER CUP
11	NA	1	ORDER 2900057
12	3000025	1	PRESSURE ROLLER SPINDLE 10"
13	4500247	1	PRESSURE ROLLER COMPLETE 10" SPINDLE
14	4800172	1	1/8" X 2" COTTER PIN
15	2900010	5	1/2" NF X 1-1/4" WHEEL STUD BOLT
16	4900094	5	1/2" NF WHEEL BOLT 13/16" O.D.
17	5000004	5	WASH\FLAT\1/2
	2900057		HUB\5-BOLT\985\COMPLETE, W\BEARINGS,SEAL & DUST CAP

## ORBIT MOTOR PARTS

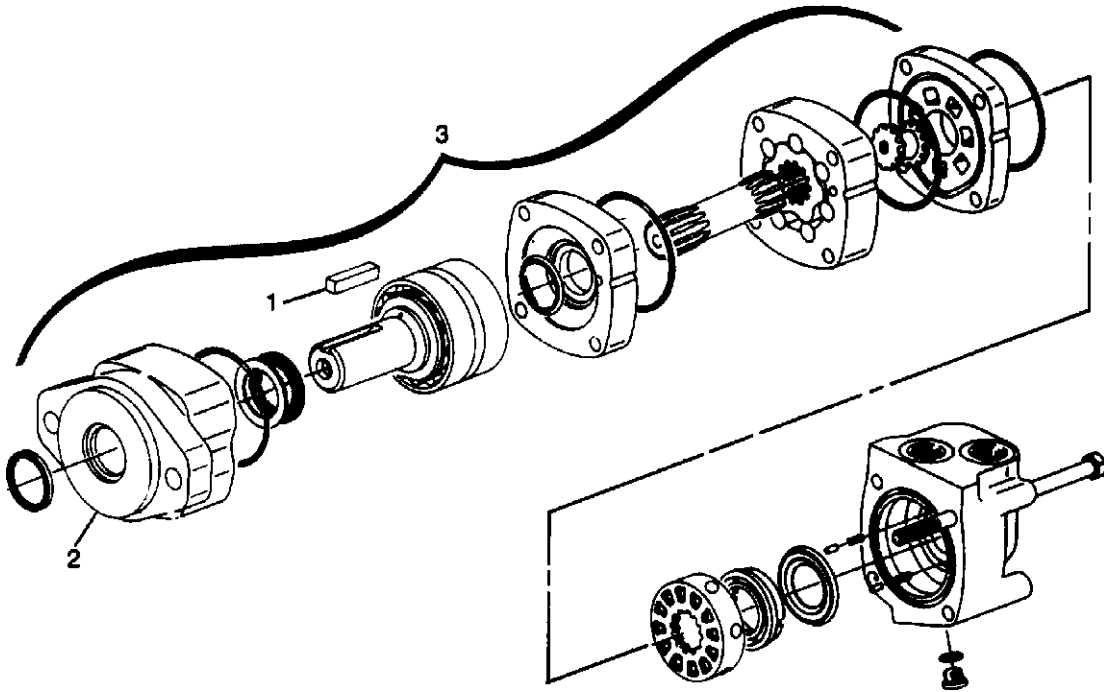

ITEM	PART	QTY.	PART DESCRIPTION
1	6200004	1	KEY\SQ\5/16X1-1/2
2	3900011	1	MOUNTING FLANGE 2000 SERIES
3	3900005		MTR\HYD\14.9\2000\SAE:A
3	3900014	1	MTR\HYD\9.6\2000\1-1/4SH
3	3900021	1	MTR\HYD\8\2000SERIES
4	7501005	1	SEAL KIT 2000 ORBIT

## HYDRAULIC ELECTRIC SOLENOID PARTS

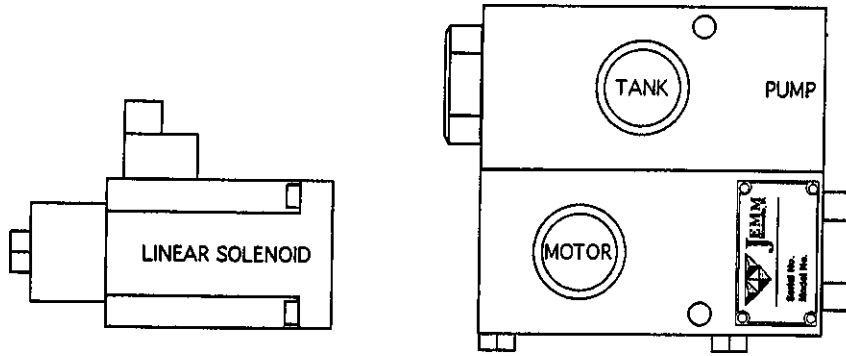

VALVE 4300030 AND 4300053

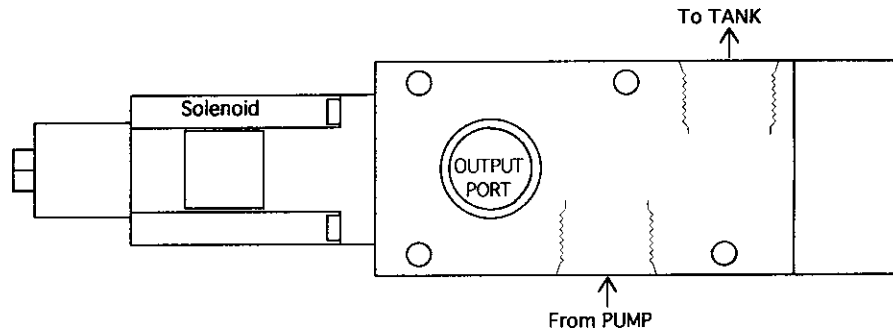

VALVE 4300064, 4300065 AND 4300069

PART	QTY.	PART DESCRIPTION
4300030	1	Hyd. Electric Solenoid Valve Complete (CV93) 12V 20GPM ORDER 4300065
4300010		Solenoid\Hyd Valve\12V, see notes below
4300053	1	Hyd. Electric Solenoid Valve Complete (CV93) 24V 20GPM ORDER 4300064
4300054		Solenoid\Hyd Valve\24V, see notes below
4300065		Valve\Servo\15gpm\12vDC
4300010		Solenoid\Hyd Valve\12V, see notes below
4300064		Valve\Servo\15gpm\24vDC
4300069		Valve\Servo\25gpm\24vDC
4300054		Solenoid\Hyd Valve\24V, see notes below

**Note** - The difference between the 12Volt and 24Volt solenoid is listed on the serial number plates.  
The solenoids are Elwood 160261-xx6 or 160261-xx9. The 6 is a 12 volt solenoid, the 9 is a 24 volt solenoid. Also, 12 or 24 are stamped on the newest serial number plates.

**GREASELINE LUBE ASSEMBLY**

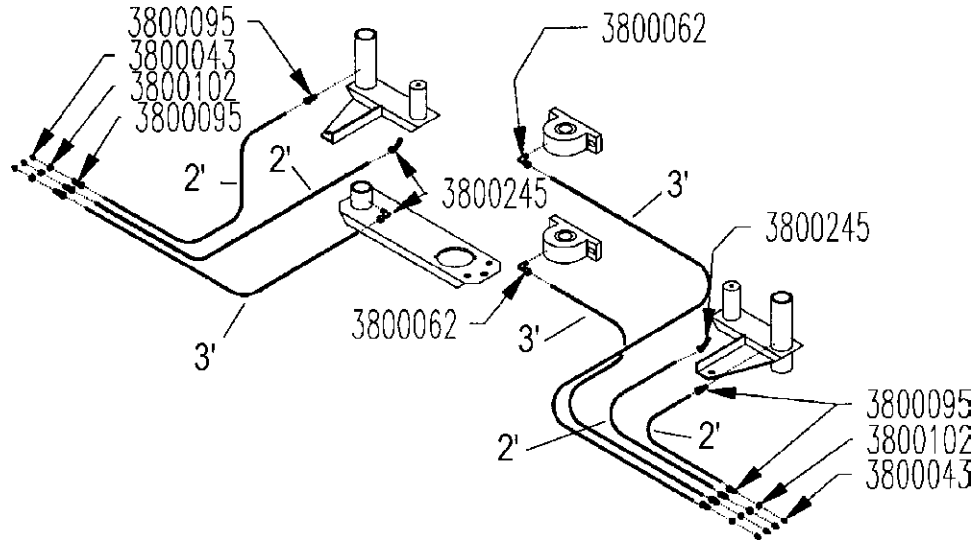

PART	QTY.	PART DESCRIPTION
4500923		LUBE\GRSLN\ASSY\SUB
3700142	BULK	HOSE\LUB\1/4\FT\NYL
3800043	7	FTG\LUB\1/8MPXZRK\SHORT
3800062	2	FTG\LUB\1/4COMPX1/8MP\90D
3800095	9	FTG\LUB\1/4COMPX1/8MP\
3800102	7	FTG\1/8FP\CPLG\LW
3800245	2	FTG\1/4COMPX1/8FP\45D

**Note** - Part 3700142 is for bulk hose. When ordering, you must specify length desired. Dimensions shown on the drawing are longer than needed. If replacing two or more lines, order a combined length of all lines. Trim to length as you install the hose.

You will need to order two fittings, (a combination of 3800062, 3800095, and 3800245, as needed) per grease line.

PART	QTY.	PART DESCRIPTION
3700427	FT	LUBE\GRSLN\ASSY\SUB
3800043	7	HOSE\LUB\1/8\FT
3800434		FTG\LUB\1/8MP;BLKHDX1/8BARB\HE\W\NUT\BULKHEAD
3800435		FTG\LUB\1/8MPSX1/8BARB\HE\SW
3800248		FTG\LUB\1/8MPX1/8FP\90D\ST;EL\SPL\LW\LUBESITE
3700642		HOSE\LUB\1/8X86\SW-SO
3700649		HOSE\LUB\1/8X24\SW-SO

**Note** – changing to high pressure lube hose Starting with II0185. Specify length of hose and type of fittings when ordering replacement hoses

## HYDRAULIC CYLINDER PARTS

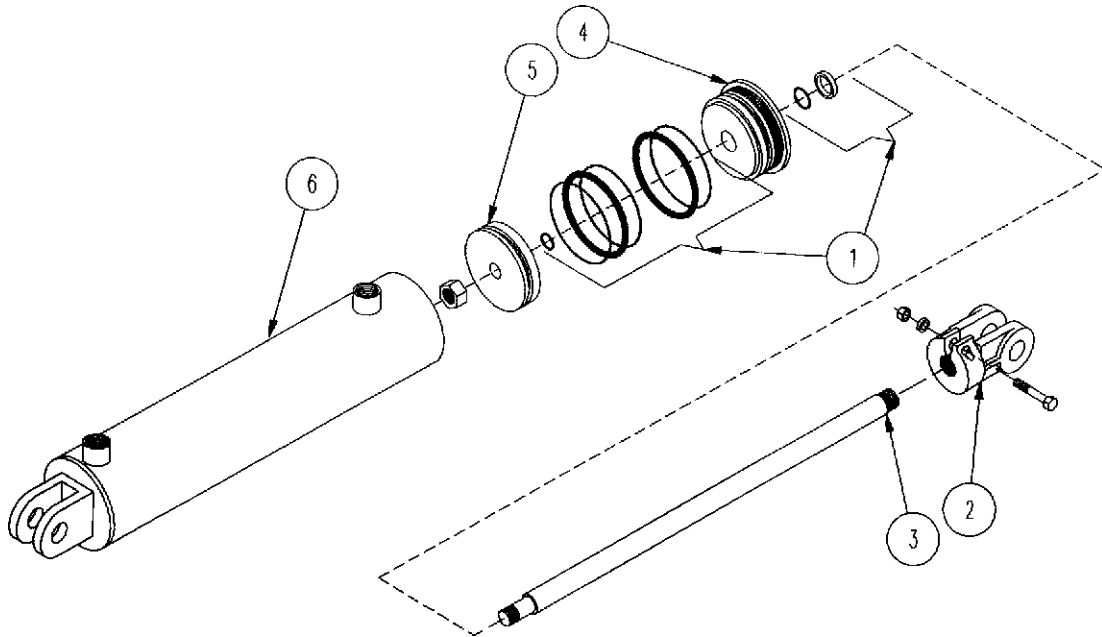

ITEM	PART	QTY.	PART DESCRIPTION
	4100086	1	CYL\HYD\3X30\1-1/2ROD\PERP
1	4100088	1	SEAL KIT3X30 1-1/2ROD
2	4100132	1	CYL\HYD\1"CLE\1"PIN\1-1/4THRD
3	4100098	1	CYL\HYD\ROD\1-1/2X30
4	4100102	1	CYL\HYD\GLAND\3"\1-1/2"ROD\
5	4100104	1	CYL\HYD\PISTON\3"\1-1/2"ROD
6	4100097	1	CYL\HYD\TUBE\3X30\PERP
	4100111	1	CYL\HYD\3X36\1-1/2ROD\PERP
1	4100103	1	CYL\HYD\SEAL KIT\3X1-1/2ROD\WELD
2	4100132	1	CYL\HYD\1"CLE\1"PIN\1-1/4THRD
3	4100186	1	CYL\HYD\ROD\1-1/2X36
4	4100102	1	CYL\HYD\GLAND\3"\1-1/2"ROD\
5	4100104	1	CYL\HYD\PISTON\3"\1-1/2"ROD

**HYDRAULIC VALVE 4000095 (O-RING)**

**MODEL BA – one spool**

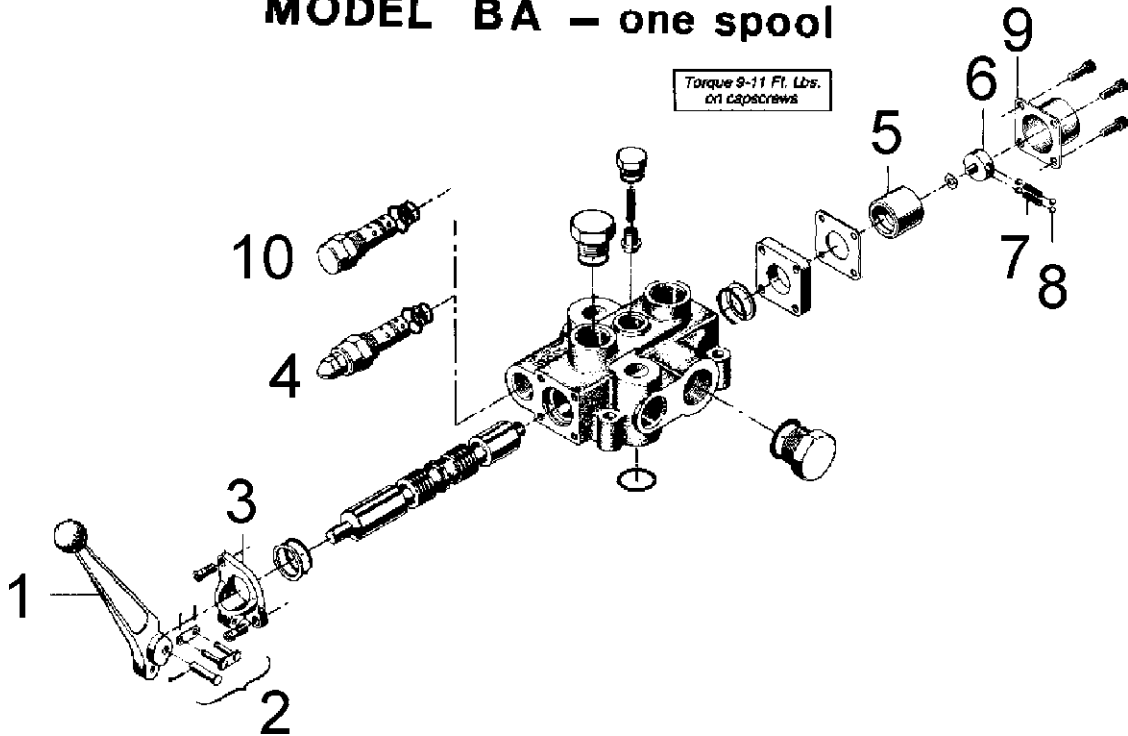

ITEM	DTI#	DESCRIPTION
1	4000001	HANDLE/HYD/VALVE BANK
2	4000002	CONNECTOR LINK W/PIN
3	4000004	BRKT/HYD/VALVE BANK
4	4000006	VALVE\ADJ\RELIEF
5	4000025	DETENT SLEEVE-HYD VALVE
6	4000026	DETENT RETAINER (SCREW)
7	4000027	DETENT SPRING-HYD VALVE
8	4000028	BALL 1/4"STEEL-HYD VALVE
9	4000029	(END CAP -HYD VALVE VALVE)
10	4000065	NON ADJ.VALVE 1R003710180
	4000021	DETENT SCREW ASSEMBLY FOR B&C VALVES
	7501013	SEAL KIT
	4000095	VALVE\HYD\1-SPLW\DETENT

## HYDRAULIC VALVE 4000093 PARTS

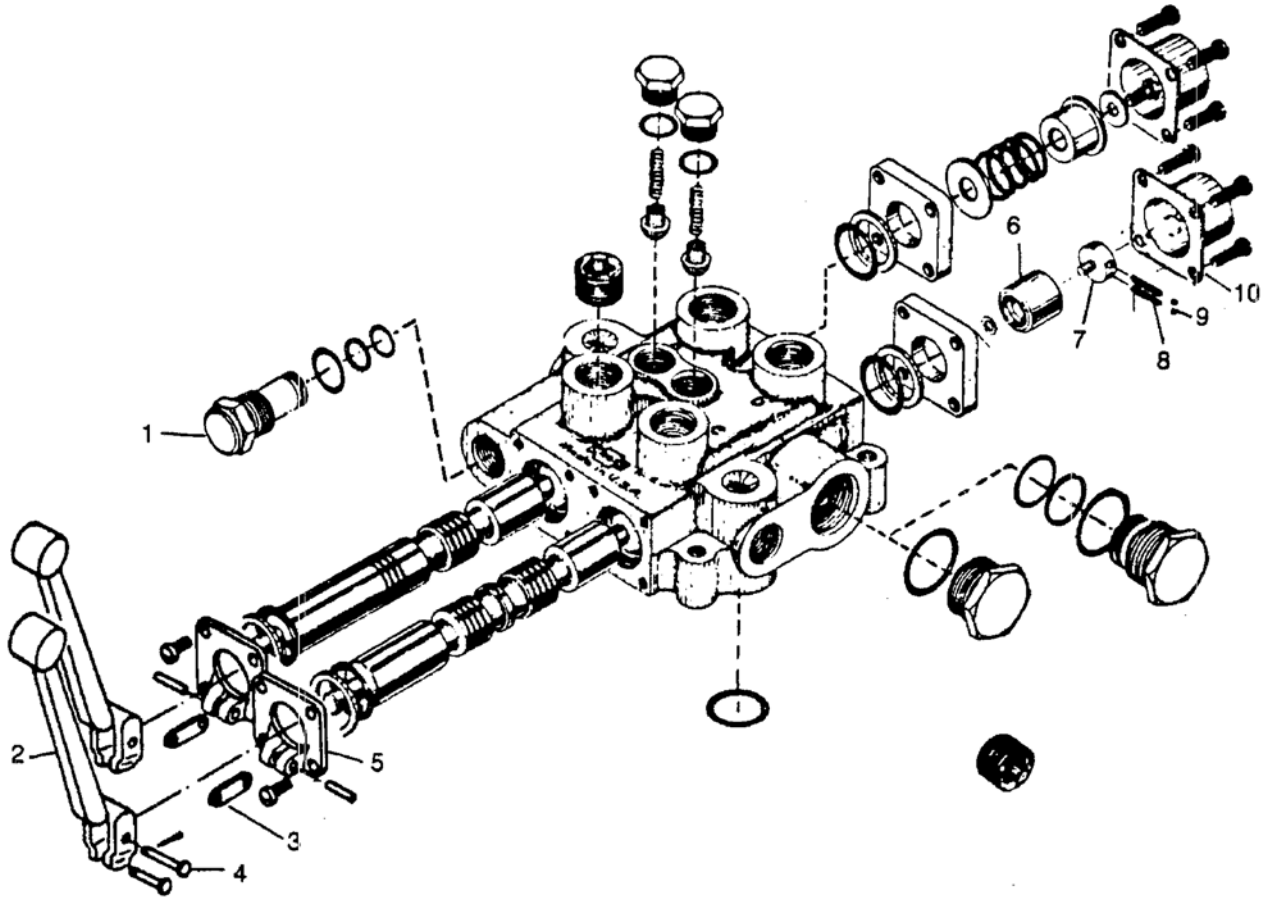

ITEM	PART	QTY.	PART DESCRIPTION
1	4000006	1	Adj. Relief Valve
1	4000065		NON ADJ. VALVE 1800 PSI
2	4000001	2	Valve Handle
3	4000002	2	Connector Links Handle w/Pin
4	4000003	2	Pin Handle with Key <b>N/A</b>
5	4000004	2	Handle Bracket
6	4000025	1	Detent Sleeve
7	4000026	1	Detent Retainer (Screw)
8	4000027	2	Detent Spring
9	4000028	4	Ball (1/4" Steel)
10	4000029	2	End Cap
11	7501004	1	Seal Kit (Not Shown)
	4000093	1	Valve Complete 2-SPL3POS-4W
	4000021	1	Detent Screw Asembly

**HYDRAULIC VALVE 4000096**

**MODEL CA (2 SPOOL)**

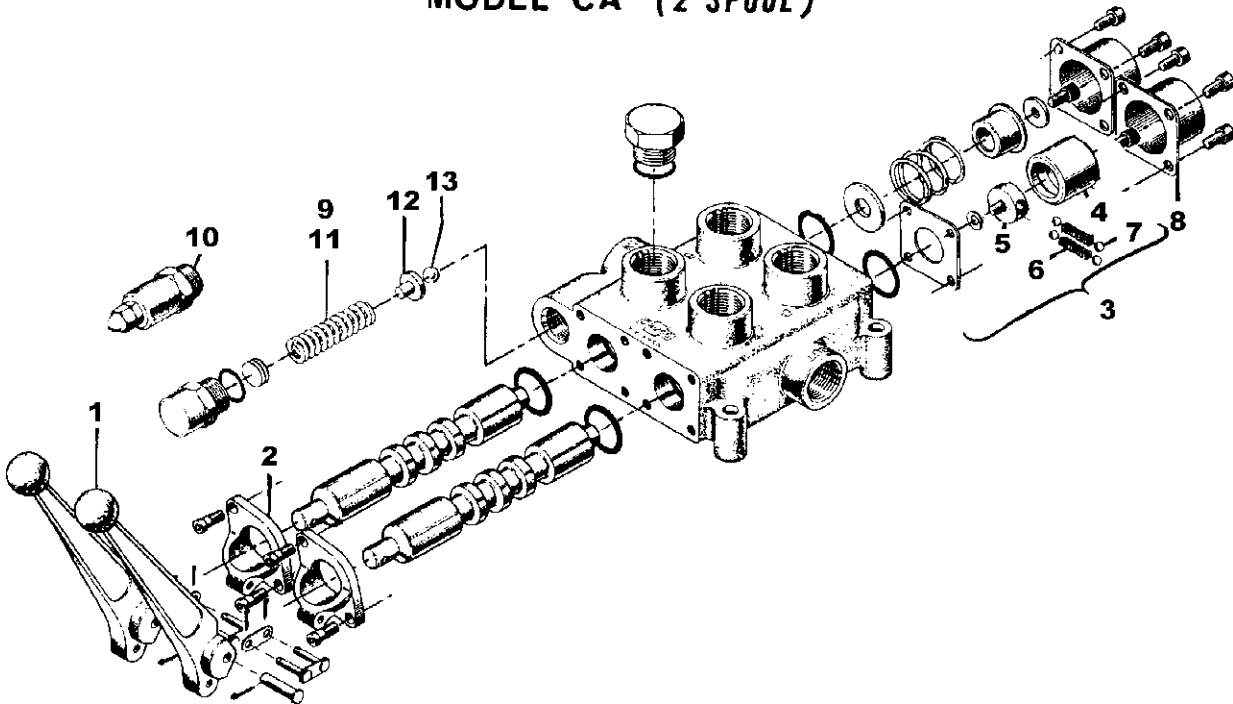

ITEM	PART	QTY.	PART DESCRIPTION
1	4000001	2	HANDLE/HYD/VALVE BANK
2	4000004	2	BRKT/HYD/VALVE BANK
3	4000021	1	DETENT SCREW ASSEMBLY
4	4000025	1	DETENT SLEEVE-HYD VALVE
5	4000026	1	DETENT RETAINER (SCREW)
6	4000027	2	DETENT SPRING-HYD VALVE
8	4000029	2	END CAP -HYD VALVE VALVE
7	4000028	4	BALL 1/4"STEEL-HYD VALVE
9	4000049	1	RELIEF VALVE SPRING 1250 TO 1750 PSI
10	4000066		1R0045 RELIEF PLUG
11	4000067		RELIEF VALVE SPRING 1750 TO 2250 PSI
12	4000068	1	1R0014 RELIEF SPRING GUID
13	4000069	1	2A0017-14 7/16 STEEL BALL
	4000096		VALVE\HYD\W\DETENT\O-RING



## HYDRAULIC VALVE 4000102 PARTS

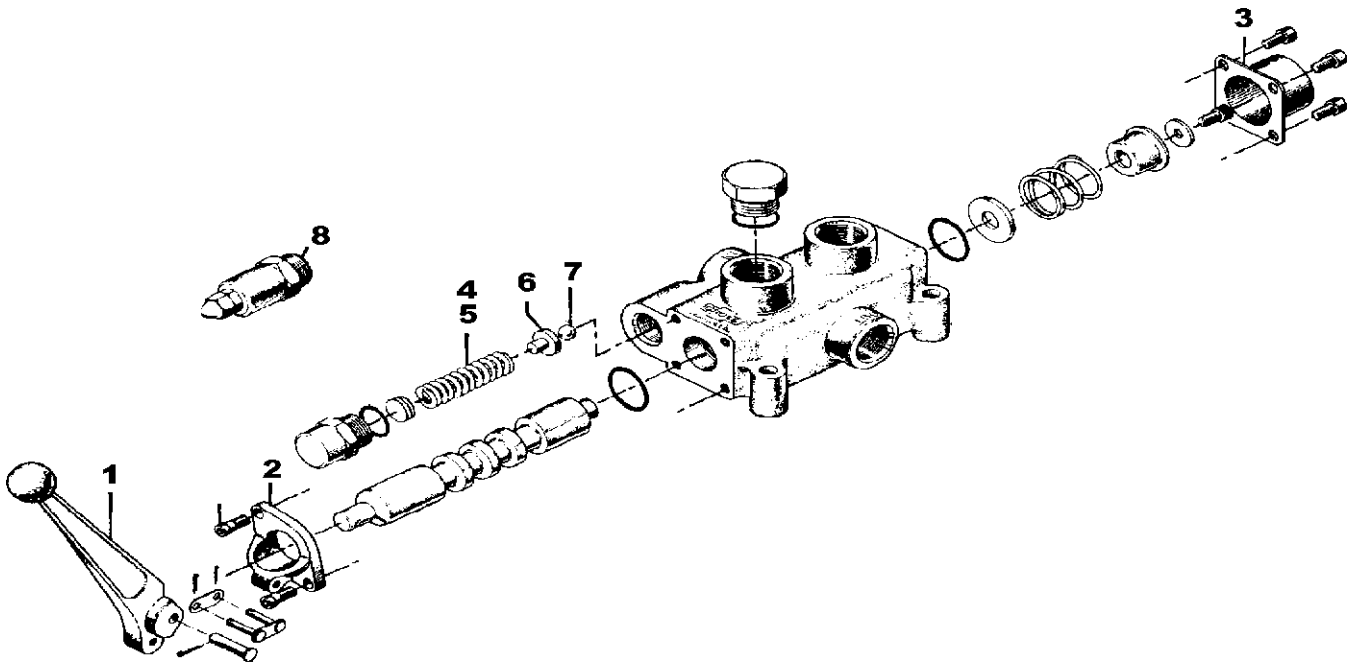

ITEM	PART	QTY.	PART DESCRIPTION
1	4000001	1	HANDLE/HYD/VALVE BANK
2	4000004	1	BRKT/HYD/VALVE BANK
3	4000029	1	END CAP -HYD VALVE VALVE
4	4000049	1	RELIEF VALVE SPRING 1250 TO 1750 PSI
5	4000067	1	RELIEF VALVE SPRING 1750 TO 2250 PSI
6	4000068	1	1R0014 RELIEF SPRING GUID
7	4000069	1	2A0017-14 7/16 STEEL BALL
8	4000066	1	1R0045 RELIEF PLUG
	4000102		VALVE\HYD\1SP

# HUB 2500453 PARTS

## 10K, 12K AND 15K HUB GROUPS

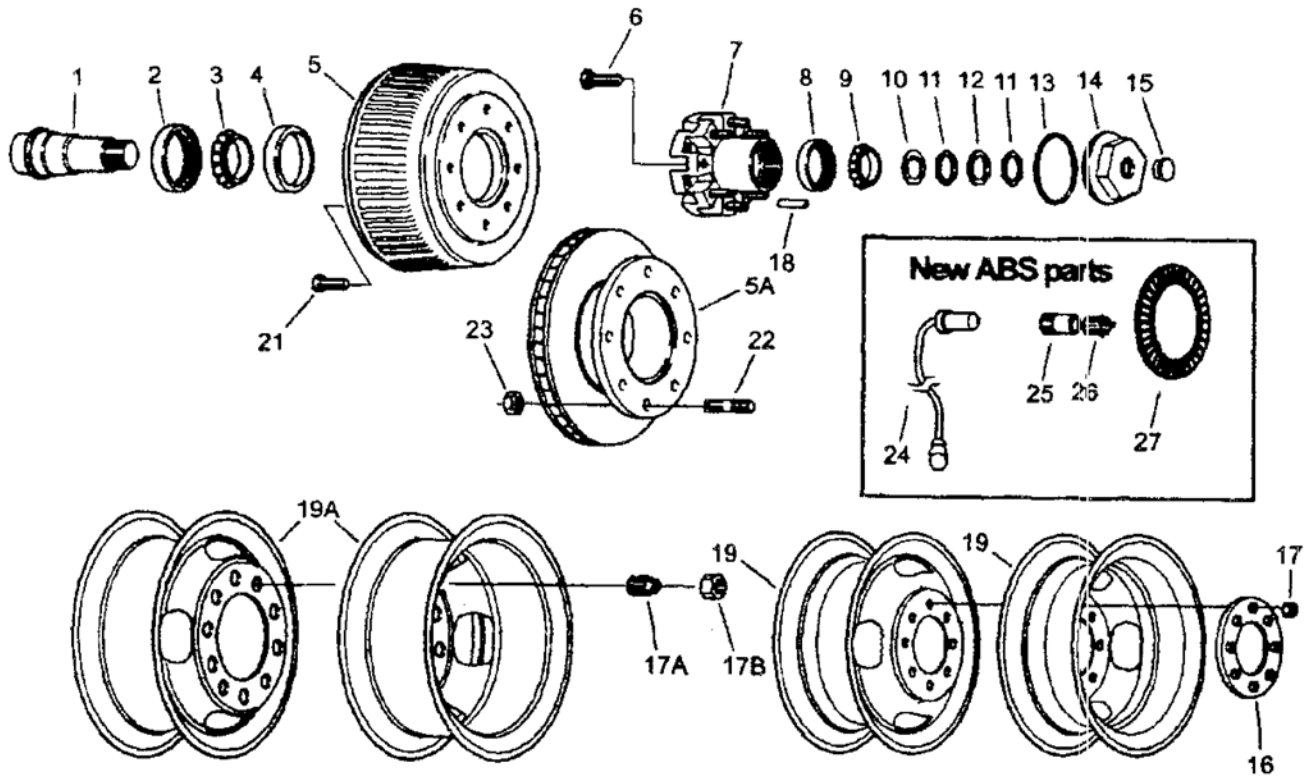

**HUB 2500453 PARTS**

<b>ITEM</b>	<b>PART NUMBER</b>	<b>PART DESCRIPTION</b>
1	2500453	AXLE\10K\74X46\H11E&HD8\” SPRING
2	2900092	UNITIZED OIL SEAL
3	2500003	INNER BEARING CONE
4	2500004	INNER BEARING CUP
5	2500019	BRAKE DRUMS
	2500019	BRAKE DRUM-ABS
6	4800254	WHEEL MTG. STUD RH
	4800254	WHEEL MTG. STUD LH
7	2900095	HUBS W/CUPS AND STUDS RH
	2900095	HUBS W/CUPS AND STUDS LH
8	2500005	OUTER BEARING CONE
9	2500006	OUTER BEARING CUP
10	2500017	SPINDLE WASHER
11	2500012	SPINDLE NUT
12	2500018	TANG WASHER
13	2500020	OIL CAP O-RING
14	2500021	OIL CAP
15	2500022	OIL CAP PLUG
	2500023	OIL FILL PLUG
16	2500627	WHEEL CLAMP RING
17	4900062	WHEEL NUT RH
18	2500403	LOCATING PIN
19	2600625	16.5X6.75 DUAL
NS		17.5X8.25 HC SINGLE
NS		17.5X6.75 HC
21	4800255	DRUM MOUNTING SCREW
24		ABS SENSOR, STRAIGHT
25		ABS SENSOR BLOCK
26		ABS SENSOR CLIP
27		ABS TONE RING

# H-1100E HAYBUSTER

6500148

6500148

6500020

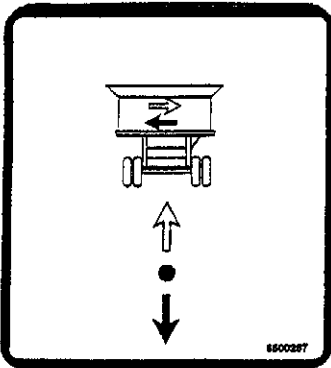

6500257



6500044



6500102

	<b>⚠ DANGER</b> <b>ROTATING PART HAZARD</b> STAY OUT OF TUB WHEN SHOWS IS RUNNING 1. KEEP OTHERS AWAY 2. PLACE ALL CONTROLS IN NEUTRAL, STOP ENGINE, REMOVE KEYS, AND WAIT FOR ALL MOVING PARTS TO STOP BEFORE SERVICING, ADJUSTING, REPAIRING, UNLOADING, OR ENTERING THE TUB FOR ANY REASON. 3. DISCONNECT DRIVEBELT ON PTO DRIVEN MODELS.	<b>⚠ PELIGRO</b> <b>PELIGRO DE PARTE GIRATORIA</b> PERMANENTE ALGUNO DE LA CUAL QUANDO EL MOVIER ESTE EN FUNCIONAMIENTO 1. MANTENIENDO ALGUNOS A OTROS PERSONALES 2. COLÓCALOS TODOS LOS CONTROLES EN PUNTO NEUTRAL, APAGUE EL MOTOR, RETIRE LA LLAVE Y ESPERE A QUE TODAS LAS PARTES EN MOVIMIENTO SE DETENGAN ANTES DE INGRESAR AL ESPACIO, AJUSTAR, REPARACIÓN, DESCARGAR O AL ENTRAER A LA TUBA POR CUALQUIER RAZÓN. 3. DESCONECTAR EL CINTURÓN EN LOS MODELOS ADORNADOS POR VOLTA DE TRABAJO.
	6500212	

<b>⚠ WARNING</b>	
<b>HIGH-PRESSURE FLUID HAZARD</b> To prevent serious injury or death: • Relieve pressure on system before repairing or adjusting or disconnecting. • Wear proper hand and eye protection when searching for leaks. Use wood or cardboard instead of hands. • Keep all components in good repair.	

	<b>⚠ DANGER</b> <b>ELECTROCUTION HAZARD</b> To prevent serious injury or death from electrocution: Stay away from power lines when operating, servicing, and repairing machinery, and transporting on roads. This machine is not grounded, electrocution may occur without direct contact.	<b>⚠ PELIGRO</b> <b>PELIGRO DE ELECTROCUCIÓN</b> Para evitar lesiones graves o la muerte por electrocución: Permanezca alejado de las líneas de electricidad al operar o reparar con brazos de trabajo, los otros transportadores o cargador o hacia y al transportar. Este equipo no tiene conexión a tierra y puede producirse un electrocución sin contacto directo.
	6500216	

6500220

<b>⚠ CAUTION</b>	<b>⚠ PRECAUCION</b>
INSERT TRANSPORT LOCKS BEFORE MOVING ON ROADS	ANTES DE DESPLAZARSE EN LA RUTA INSERTE LOS SEGUROS DE TRANSPORTE

6500112

	<b>⚠ WARNING</b> <b>OVERHEAD CONVEYOR HAZARD</b> To prevent serious injury or death: Do not walk under conveyor at any time. Stay clear of conveyor during loading operations. Check that transport bars are fully engaged before transporting on roads or servicing. Keep others away.	<b>⚠ ADVERTENCIA</b> <b>PELIGRO DE CINTA TRANSPORTADORA ELEVADA</b> Para evitar lesiones graves o la muerte: No camine por debajo de la cinta transportadora en ningún momento. Permanezca alejado de la cinta transportadora durante las operaciones de carga. Verifique que todas las barras de transporte estén completamente comprometidas antes de proceder al transporte por caminos o al servicio. Mantenga alejados a otros personas.
	6500215	



6500253

	<b>⚠ WARNING</b> <b>OVERHEAD CONVEYOR HAZARD</b> To prevent serious injury or death: Do not walk under conveyor at any time. Stay clear of conveyor during operation, loading, and unloading. Lower conveyor fully before servicing. Keep others away.	<b>⚠ ADVERTENCIA</b> <b>PELIGRO DE CINTA TRANSPORTADORA ELEVADA</b> Para evitar lesiones graves o la muerte: No camine por debajo de la cinta transportadora en ningún momento. Permanezca alejado de la cinta transportadora durante las operaciones de carga y la descarga. Baje completamente la cinta transportadora antes de proceder al servicio. Mantenga alejados a otras personas.
	6500214	



6500056

## H-1100E DECALS

PART	QTY.	PART DESCRIPTION
6500020	2	Haybuster W/Sunburst
6500039	1	Serial # Decal
6500041	1	For Your Protection
6500043	1	No Riders
6500044	2	Big Bite (Red)
6500056	2	Rotation
6500102	27 Ft.	Stripe (Red)
6500112	2	Transport Locks
6500118	1	Danger : Objects Thrown
6500121	1	Clutch
6500123	2	Diesel Fuel
6500124	2	Hydraulic Oil
6500148	2	H1100E
6500209	1	Warning: Thrown Object Hazard
6500212	1	Rotating Parts Hazard
6500214	1	Overhead Conveyor Hazard
6500215	1	Overhead Conveyor Hazard
6500216	1	Warning: Electrical Hazard
6500220	2	Warning: High Pressure Hazard
6500253	2	Oil Level
6500255	1	Conveyor Up/Down (Picture Only)
6500256	1	Conveyor Belt Rotation\Tub Up/Down(Picture Only)
6500257	1	Tub Rotation (Picture Only)
6500258	1	Conveyor Up/Down (Picture Only)
6500274		Decal\Info\Tub;Pressure
6500275		Decal\Info\Cnvyr;Pressure
6500266		DECAL\KIT\H1100E\96
7500077		12 Oz Yellow Spray Paint
7500092		Quart Yellow Paint
7500091		Gallon Yellow Paint
7500078		12 Oz Red Spray Paint
7500105		Quart Red Paint
7500104		Gallon Red Paint

H-1100E DECALS

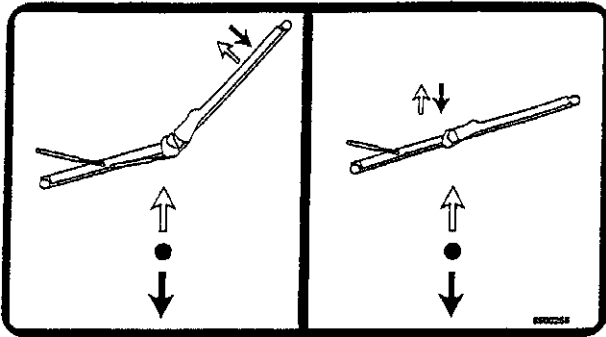

6500258

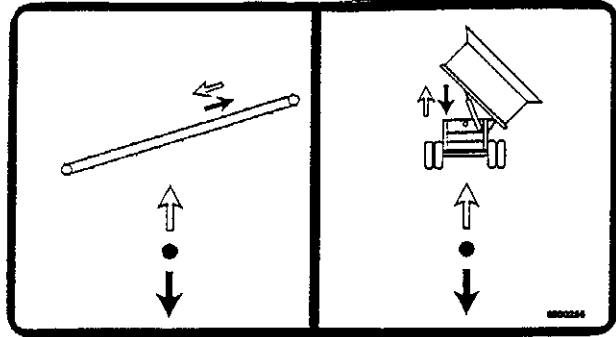

6500256

<b>⚠ WARNING</b>	<b>⚠ ADVERTENCIA</b>
<p><b>FOR YOUR PROTECTION AND PROTECTION OF OTHERS, PRACTICE THE FOLLOWING SAFETY RULES.</b></p> <ol style="list-style-type: none"> <li>BEFORE OPERATING THIS MACHINE, READ THE OPERATOR'S MANUALS SUPPLIED WITH THIS MACHINE AND YOUR TRACTOR.</li> <li>CHECK OPERATOR'S MANUALS TO BE SURE YOUR TRACTOR MEETS THE MINIMUM REQUIREMENTS FOR THIS MACHINE.</li> <li>READ ALL DECALS PLACED ON THIS MACHINE FOR YOUR SAFETY AND CONVENIENCE.</li> <li>NEVER ALLOW RIDERS ON THIS IMPLEMENT OR THE TRACTOR.</li> <li>KEEP OTHERS AWAY FROM THIS MACHINE WHILE IN OPERATION.</li> <li>KEEP ALL BODIES IN PLACE WHILE MACHINE IS OPERATING.</li> <li>KEEP HANDS, FEET, LOOSE CLOTHING, ETC., AWAY FROM POWER-DRIVEN PARTS.</li> <li>ALWAYS SHUT OFF MACHINE AND ENGINE BEFORE SERVICING, UNLOADING, WAXING, OR WORKING NEAR THIS MACHINE FOR ANY REASON. ALWAYS PLACE TRANSMISSION IN PARK OR SET PARK BRAKE AND WAIT FOR ALL MOVEMENT TO STOP BEFORE APPROACHING THIS MACHINE.</li> </ol>	<p><b>SIGA LAS REGLAS SIGUIENTES DE SEGURIDAD PARA SU PROTECCION Y LA PROTECCION DE OTROS</b></p> <ol style="list-style-type: none"> <li>LEA LOS MANUALES DEL OPERADOR INCLUIDOS CON ESTA MAQUINA Y SU TRACTOR ANTES DE OPERAR ESTA MAQUINA.</li> <li>PARA ASEGURARSE QUE SU TRACTOR CUMPLE CON LOS REQUERIMIENTOS MÍNIMOS PARA ESTA MAQUINA, REVISE LOS MANUALES DEL OPERADOR.</li> <li>PARA SU SEGURIDAD Y CONVENIENCIA, LEA TODAS LAS CALCOMANIAS COLOCADAS EN LA MAQUINA.</li> <li>NUNCA PERMITA PASAJEROS EN ESTA MAQUINA O EN EL TRACTOR.</li> <li>MANTÉNGASE AJUSTADOS A LOS ESPECTADORES MIENTRAS ESTA MAQUINA ESTE OPERANDO.</li> <li>MANTÉNGA TODOS LOS PROTECTORES EN SU LUGAR MIENTRAS LA MAQUINA ESTE OPERANDO.</li> <li>MANTÉNGA LAS MANOS, PIES, ROPAS MOLDAJAS, ETC., AJUSTADAS DE LAS PIEZAS PROYECTADAS.</li> <li>SIEMPRE APAGUE LA MAQUINA Y EL MOTOR ANTES DE PRESTAR SERVICIO, DESTRABAR, INSPECCIONAR O TRABAJAR CERCA DE ESTA MAQUINA POR CUALQUIER MOTIVO. ANTES DE ACERCARSE A ESTA MAQUINA COLÓQUE SIEMPRE LA TRANSMISIÓN EN ESTACIONAMIENTO O BLOQUEE EL FRENO DE ESTACIONAMIENTO.</li> </ol>

6500041

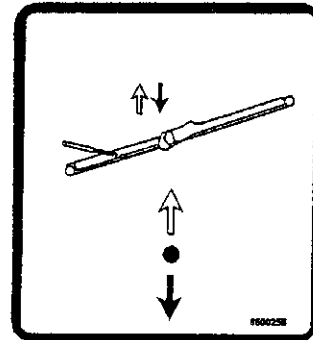

6500255

**IMPORTANT**

DO NOT ENGAGE CLUTCH AT HIGH ENGINE RPM. BEFORE STARTING ENGINE, CYLINDER BOX SHOULD BE CLEARED OF ALL MATERIAL. SET ENGINE AT APPROXIMATELY 1000 RPM. PULL FIRMLY ON LEVER WHEN ENGAGING CLUTCH TO PREVENT EXCESSIVE SLIPPING. CHECK PERIODICALLY FOR PROPER ADJUSTMENT ACCORDING TO SPEC. PLATE ON CLUTCH HOUSING.

**ADJUSTMENT**

CLUTCH If the clutch does not pull, overhaul, or the clutch operating lever jerks out, the clutch must be adjusted. To adjust the clutch remove the hand hole plate in the housing and rotate the adjuster until the adjusting lock screw can be reinserted. Remove or change the adjustment ring lock.

**HE CLUTCH** Turn the adjusting ring counter clockwise to obtain recommended operating lever pressure.

**HD CLUTCH** Turn the adjusting ring clockwise to obtain recommended operating lever pressure.

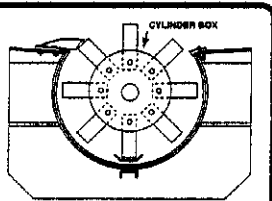

A new clutch generally requires several adjustments until the friction surfaces are worn in. Do not let a clutch slip as this will glaze the friction plates and may ruin them.

**DAMAGE DUE TO EXCESSIVE SLIPPING WILL NOT BE COVERED BY WARRANTY.**

6500121

<b>⚠ DANGER</b>	
<p><b>OBJECTS THROWN BY MACHINE. DO NOT OPERATE WITHOUT WEARING SAFETY GLASSES AND A HARD HAT. KEEP UNAUTHORIZED PERSONNEL OUT OF THE GRINDING AREA!</b></p>	

6500118

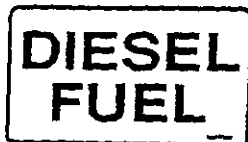

6500123



6500274



6500124



6500275

<b>⚠ WARNING</b>	<b>⚠ ADVERTENCIA</b>
<p><b>NO RIDERS</b></p> <p>SERIOUS PERSONAL INJURY COULD RESULT FROM RIDING ON THE MACHINE</p>	<p><b>PASAJEROS PROHIBIDOS</b></p> <p>PODRIAN RESULTAR LESIONES PERSONALES GRAVES AL VIAJAR EN LA MAQUINA</p>

6500043

<b>⚠ WARNING</b>	<b>⚠ ADVERTENCIA</b>
<p><b>THROWN OBJECT HAZARD</b></p> <p>TO PREVENT PERSONAL INJURY OR DEATH, DO NOT RAISE TUB WHILE MOTOR IS RUNNING</p> <ol style="list-style-type: none"> <li>Always ensure tub is lowered to ground before starting motor.</li> <li>Do not raise tub until fully lowered and motor is stopped.</li> <li>Always use proper technique when raising tub.</li> <li>Do not stand or work near tub while it is being raised.</li> </ol>	<p><b>PELIGRO DE OBJETOS DESPEDIIDOS</b></p> <p>PARA EVITAR LESIONES GRAVES O LA MUERTE, NO LEVANTE LA CUBA CUANDO EL MOTOR ESTE CORRIENDO</p> <ol style="list-style-type: none"> <li>Siempre asegure que la cuba está bajada al suelo antes de arrancar el motor.</li> <li>No levante la cuba hasta que esté completamente bajada y el motor haya parado.</li> <li>Siempre use la técnica correcta al levantar la cuba.</li> <li>No se quede de pie o trabaje cerca de la cuba cuando se está elevando al suelo.</li> </ol>

6500209

## H-1100E DECALS

PART	QTY.	PART DESCRIPTION
6500020	2	Haybuster W/Sunburst
6500039	1	Serial # Decal
6500041	1	For Your Protection
6500043	1	No Riders
6500044	2	Big Bite (Red)
6500056	2	Rotation
6500102	27 Ft.	Stripe (Red)
6500112	2	Transport Locks
6500118	1	Danger : Objects Thrown
6500121	1	Clutch
6500123	2	Diesel Fuel
6500124	2	Hydraulic Oil
6500148	2	H1100E
6500209	1	Warning: Thrown Object Hazard
6500212	1	Rotating Parts Hazard
6500214	1	Overhead Conveyor Hazard
6500215	1	Overhead Conveyor Hazard
6500216	1	Warning: Electrical Hazard
6500220	2	Warning: High Pressure Hazard
6500253	2	Oil Level
6500255	1	Conveyor Up/Down (Picture Only)
6500256	1	Conveyor Belt Rotation\Tub Up/Down(Picture Only)
6500257	1	Tub Rotation (Picture Only)
6500258	1	Conveyor Up/Down (Picture Only)
6500274		Decal\Info\Tub;Pressure
6500275		Decal\Info\Cnvyr;Pressure
6500266		DECAL\KIT\H1100E\96
7500077		12 Oz Yellow Spray Paint
7500092		Quart Yellow Paint
7500091		Gallon Yellow Paint
7500078		12 Oz Red Spray Paint
7500105		Quart Red Paint
7500104		Gallon Red Paint

OPTION: ENGINE 3306 CAT

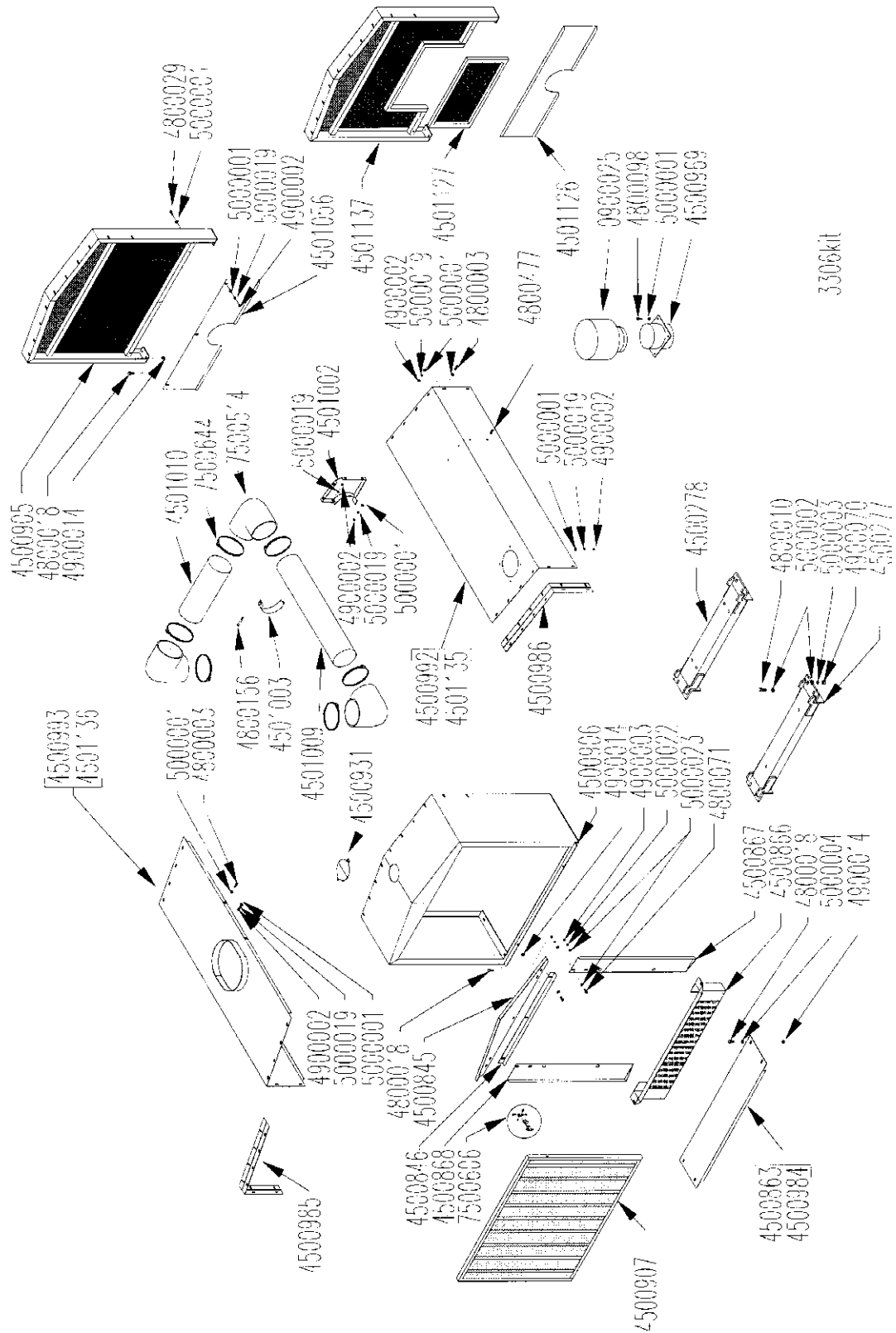

3306kit



**OPTION: ENGINE 3306 CAT**

<b>PART</b>	<b>QTY.</b>	<b>PART DESCRIPTION</b>
4500919		OPTN\ENG\GRNDR\3306
0900005	1	ENG\CAT\3306\300HP\W/ROD
0900025	1	TURBO II PRECLEANER 7"
4500277	1	FRONT CAT ENG MOTOR MOUNT
4500278	1	REAR CAT ENG MOTOR MOUNT
4500845	1	SEAL\RAD\TOP\CAT3406;3306
4500846	1	SEAL\RAD\REAR\TOP\CAT
4500863	1	CVR\FRAME\FRONT\CAT-3306
4500866	1	SEAL\RAD\LOWER\CAT-3306
4500867	1	SEAL\RAD\SIDE\LH\CAT-3306
4500868	1	SEAL\RAD\SIDE\RH\CAT-3306
4500905	1	FRM\SHRD\RAD\REAR\3306 for SN up to HI0174
4500906	1	FRAME\SHROUD\RAD\FRONT
4500907	1	GRILLE\SHROUD\RAD\FRONT
4500931	1	CVR\ACCESS\RAD\SHROUD
4500969	1	BRKT\PRECLNR\TURBOII
4500984	1	CVR\FRAME\FRONT\CAT-3306 w/TWINDISC CLUTCH
4500985	1	SPCR\HOOD\RH\3306\W/TWINDISC CLUTCH
4500986	1	SPCR\HOOD\LH\3306\W/TWINDISC CLUTCH
4500992	1	CVR\ENG\LH\CAT-3306
4500993	1	CVR\ENG\RH\CAT-3306
4501002	2	BRKT\TUBE\AIR
4501003	2	CLMP\BRKT\AIR
4501009	1	TUBE\PRCLNR\7X38\TURBOII
4501010	1	TUBE\PRCLNR\7X20\TURBOII
4501056	1	SHLD\DRVLN\ENG\H1100E for SN up to HI0174
4501126		SHIELD\DRLINE for SN HI0175 and up
4501127		DOOR\ACCESS\CLUTCH for SN HI0175 and up
4501137		SHRD\ENG\REAR for SN HI0175 and up
4800003	26	BOLT\HEX\3/8X1
4800010	8	BOLT\HEX\5/8X2
4800018	12	BOLT\HEX\1/2X1-1/4
4800029	3	BOLT\HEX\3/8X2-1/2
4800071	11	BOLT\HEX\5/16X1-1/4
4800098	4	BOLT\HEX\3/8X1-1/4\NC
4800156	4	BOLT\HEX\3/8X3
4800477	8	BOLT\CRG\3/8X1-1/2\NC
4900002	55	NUT\HEX\3/8\NC
4900003	11	NUT\HEX\5/16\NC
4900014	12	NUT\TPLCK\1/2\NC\.500"MAX
4900070	8	NUT\HEX\5/8\GR8\NC
5000001	74	WASH\FLAT\3/8
5000002	16	WASH\FLAT\5/8
5000003	8	WASH\LOCK\5/8
5000004	4	WASH\FLAT\1/2
5000019	45	WASH\LOCK\3/8
5000022	11	WASH\LOCK\5/16
5000023	22	WASH\FLAT\5/16
7500514	3	FTG\RBBR\7\90DEG\EL
7500606	2	LATCH\35-MAUSTIN
7500644	7	CLMP\HOSE\7

OPTION: ENGINE 3406 CAT

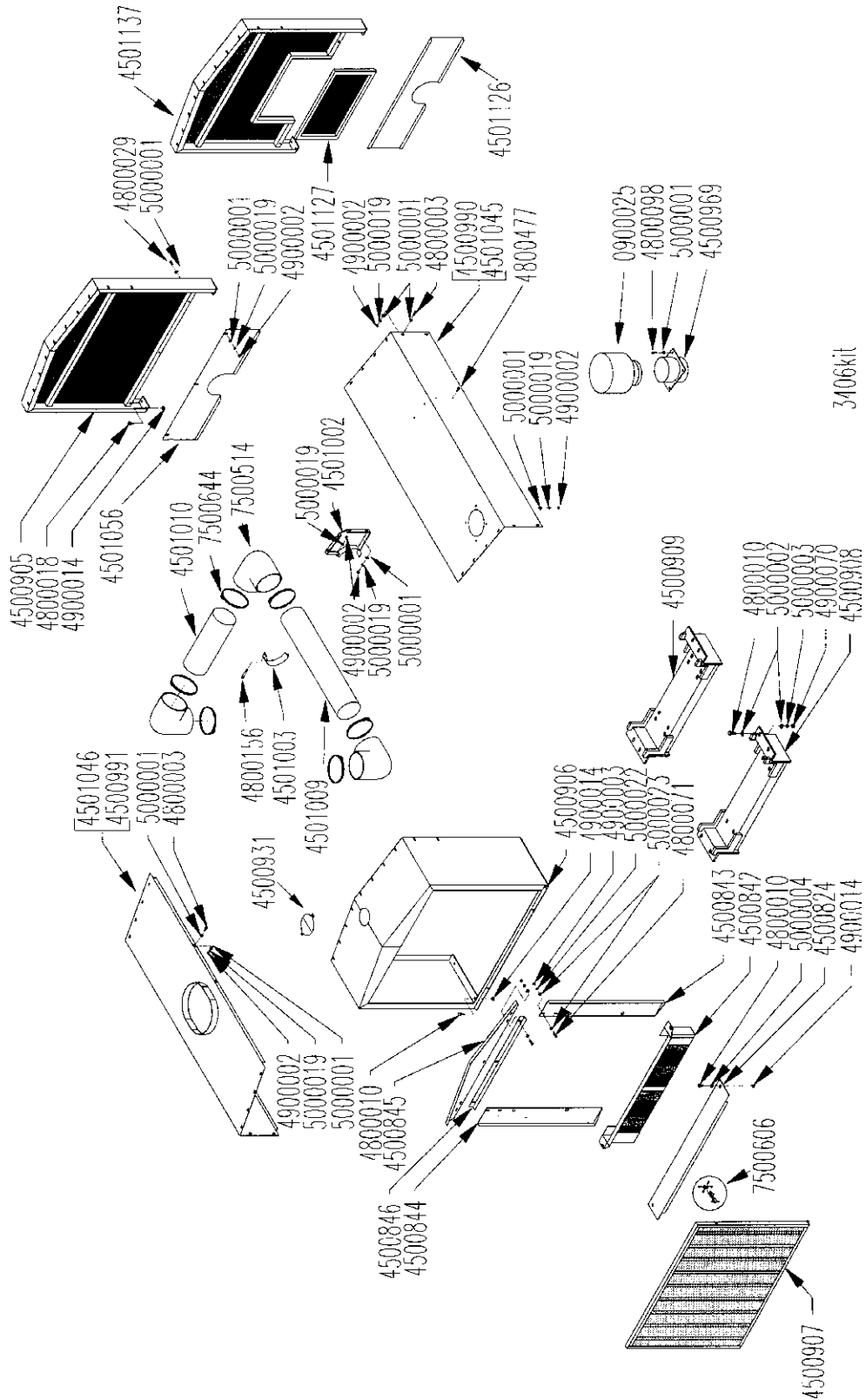

**OPTION: ENGINE 3406 CAT**

<b>PART</b>	<b>QTY.</b>	<b>PART DESCRIPTION</b>
4500904		OPTN\ENG\3406 460\CAT
4501081		OPTN\ENG\3406 400\CAT
0900010	1	ENG\CAT\3406\400 HP
0900057	1	ENG\CAT\3406\460 HP
0900025	1	TURBO II PRECLEANER 7"
4500824	1	CVR\FRM\FRONT\CAT-3406
4500842	1	SEAL\RAD\LOWER\CAT-3406
4500843	1	SEAL\RAD\SIDE\LH\CAT-3406
4500844	1	SEAL\RAD\SIDE\RH\CAT-3406
4500845	1	SEAL\RAD\TOP\CAT-3406,3306
4500846	1	SEAL\RAD\REAR\TOP\CAT-3406
4500905	1	FRAME\SHROUD\RAD\REAR for SN up to HI0174
4500906	1	FRAME\SHROUD\RAD\FRONT
4500907	1	GRILLE\SHROUD\FRONT
4500908	1	BRKT\ENG\FRONT\3406
4500909	1	BRKT\ENG\REAR\3406
4500931	1	CVR\ACCESS\RAD\SHROUD
4500969	1	BRKT\PRECLNR\TURBOII
4500990	1	CVR\ENG\LH\CAT-3406
4500991	1	CVR\ENG\RH\CAT-3406
4501002	2	BRKT\TUBE\AIR
4501003	2	CLMP\BRKT\AIR
4501009	1	TUBE\PRCLNR\7X38\TURBOII
4501010	1	TUBE\PRCLNR\7X20\TURBOII
4501045		CVR\ENG\LH\CAT-3406 w/TWINDISC CLUTCH
4501046		CVR\ENG\LH\CAT-3406 w/TWINDISC CLUTCH
4501056	1	SHLD\DRVLN\ENG\H1100E for SN up to HI0174
4501126		SHIELD\DRLINE for SN HI0175 and up
4501127		DOOR\ACCESS\CLUTCH for SN HI0175 and up
4501137		SHRD\ENG\REAR for SN HI0175 and up
4800003	32	BOLT\HEX\3/8X1
4800010	18	BOLT\HEX\5/8X2
4800018	4	BOLT\HEX\1/2X1-1/4
4800029	3	BOLT\HEX\3/8X2-1/2
4800071	11	BOLT\HEX\5/16X1-1/4
4800098	4	BOLT\HEX\3/8X1-1/4/NC
4800156	4	BOLT\HEX\3/8X3
4800447	8	BOLT\CRG\3/8X1-1/2/NC
4900002	41	NUT\HEX\3/8\NC
4900003	11	NUT\HEX\5/16\NC
4900014	10	NUT\TPLCK\1/2\NC\500 MAX
4900070	8	NUT\HEX\5/8\GR8\NC
5000001	80	WASH\FLAT\3/8
5000002	16	WASH\FLAT\5/8
5000003	8	WASH\LOCK\5/8
5000004	2	WASH\FLAT\1/2
5000019	55	WASH\LOCK\3/8
5000022	11	WASH\LOCK\5/16
5000023	22	WASH\FLAT\5/16
7500514	3	FTG\RBBR\7\90DEG\EL
7500606	2	LATCH\35-MAUSTIN
7500644	7	CLMP\HOSE\7
0900118		RAD\ENG\ATLAS\CAT\3406
5700112		BLKHTR\120\1500\3408\3406
4501255		CVR\MUFFLER\H1100E
4501270		DFLCTR\AIR\MUFFLER

OPTION: ENGINE CUMMINS N-14

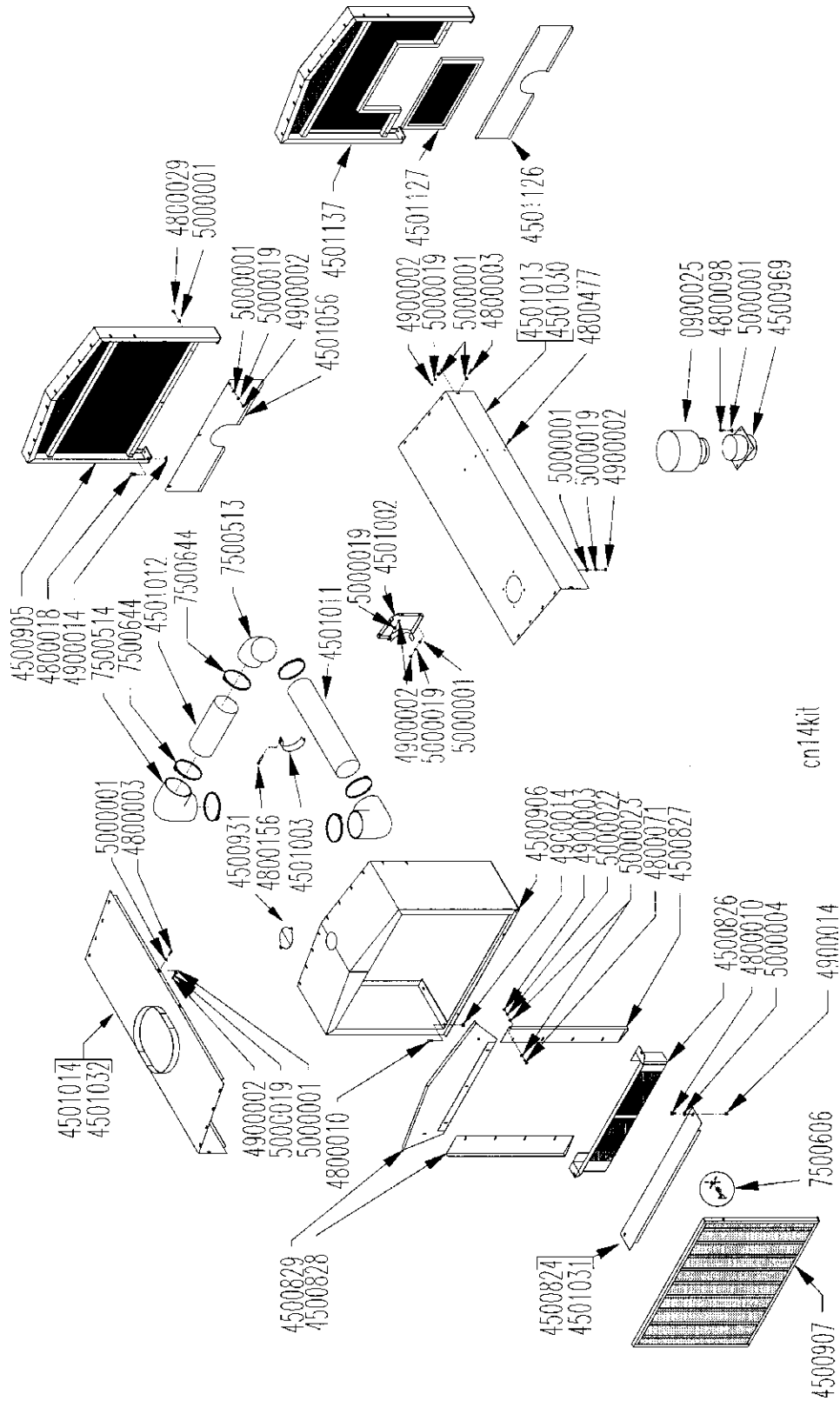

**OPTION: ENGINE CUMMINS N-14**

<b>PART</b>	<b>QTY.</b>	<b>PART DESCRIPTION</b>
4500910		OPTN\ENG\GRDR\CUMMINS\N14
0900025	1	TURBO II PRECLEANER 7"
0900065	1	ENG\CUMMINS\N-14\425HP
4500824	1	CVR\FRM\FRONT\CAT-3406
4500826	1	SEAL\RAD\LOWER\CUMMINS
4500827	1	SEAL\RAD\SIDE\LH\CUMMINS
4500828	1	SEAL\RAD\SIDE\RH\CUMMINS
4500829	1	SEAL\RAD\TOP\CUMMINS
4500905	1	FRAME\SHROUD\RAD\REAR for SN up to HI0174
4500906	1	FRAME\SHROUD\RAD\FRONT
4500907	1	GRILLE\SHROUD\RAD\FRONT
4500931	1	CVR\ACCESS\RAD\SHROUD
4500969	1	BRKT\PRECLNR\TURBOII
4501002	2	BRKT\TUBE\AIR
4501003	2	CLMP\BRKT\AIR
4501011	1	TUBE\PRCLNR\7X32\TURBOII
4501012	1	TUBE\PRCLNR\7X17\TURBOII
4501013	1	CVR\ENG\LH\CAT-3406
4501014	1	CVR\ENG\RH\CAT-3406
4501030		CVR\ENG\LH\CAT-3406 w/TWINDISC CLUTCH
4501031	1	CVR\FRM\FRONT\CN-14 w/TWINDISC CLUTCH
4501032		CVR\ENG\LH\CAT-3406 w/TWINDISC CLUTCH
4501056	1	SHLD\DRVLN\ENG\H1100E for SN up to HI0174
4501126		SHIELD\DRLINE for SN HI0175 and up
4501127		DOOR\ACCESS\CLUTCH for SN HI0175 and up
4501137		SHRD\ENG\REAR for SN HI0175 and up
4800003	28	BOLT\HEX\3/8X1
4800010	10	BOLT\HEX\5/8X2
4800018	4	BOLT\HEX\1/2X1-1/4
4800029	3	BOLT\HEX\3/8X2-1/2
4800071	11	BOLT\HEX\5/16X1-1/4
4800098	4	BOLT\HEX\3/8X1-1/4\NC
4800156	4	BOLT\HEX\3/8X3
4800447	8	BOLT\CRG\3/8X1-1/2\NC
4900002	22	NUT\HEX\3/8\NC
4900003	11	NUT\HEX\5/16\NC
4900014	10	NUT\TPLCK\1/2\NC\500 MAX
5000001	50	WASH\FLAT\3/8
5000004	2	WASH\FLAT\1/2
5000019	28	WASH\LOCK\3/8
5000022	11	WASH\LOCK\5/16
5000023	11	WASH\FLAT\5/16
7500513	1	FTG\RBBR\7\45DEG\EL
7500514	2	FTG\RBBR\7\90DEG\EL
7500606	2	LATCH\35-M\AUSTIN
7500644	7	CLMP\HOSE\7

**OPTION: GRAIN HOPPER**

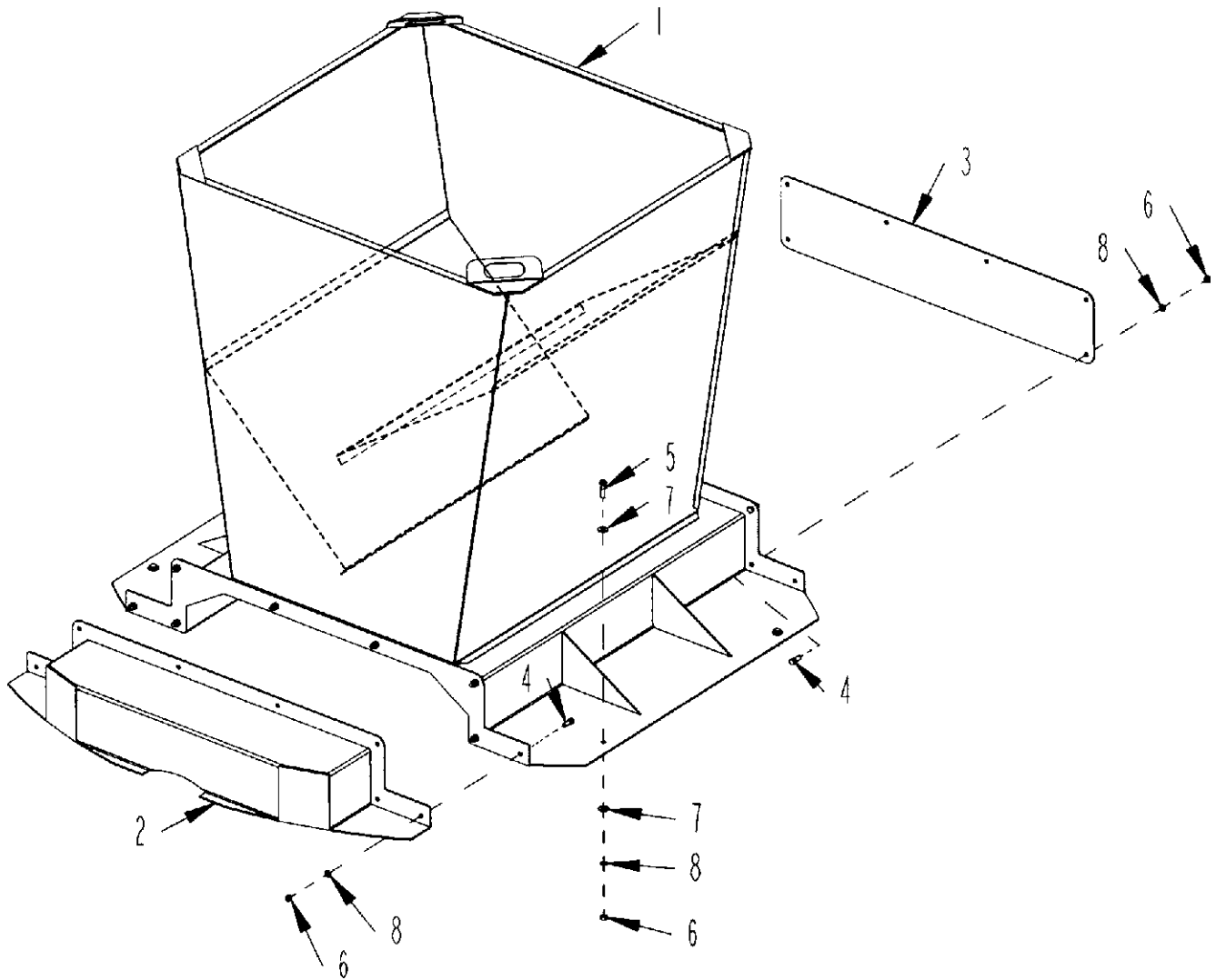

PART	QTY.	PART DESCRIPTION
4501347		HPPR\GRAIN\ASSY\COMPLETE
4501335	1	HPPR\GRAIN
4501340	1	CVR\RTR\HPPR\GRAIN
4501341	1	CVR\END\HPPR\GRAIN
4501004	1	HOPPER\GRAIN\H1100E
4800003	14	BOLT\HEX\3/8X1
4800034	4	BOLT\HEX\3/8X1-1/2
4900002	18	NUT\HEX\3/8\NC
5000001	8	WASH\FLAT\3/8
5000019	18	WASH\LOCK\3/8

**OPTION: EAR CORN KIT**

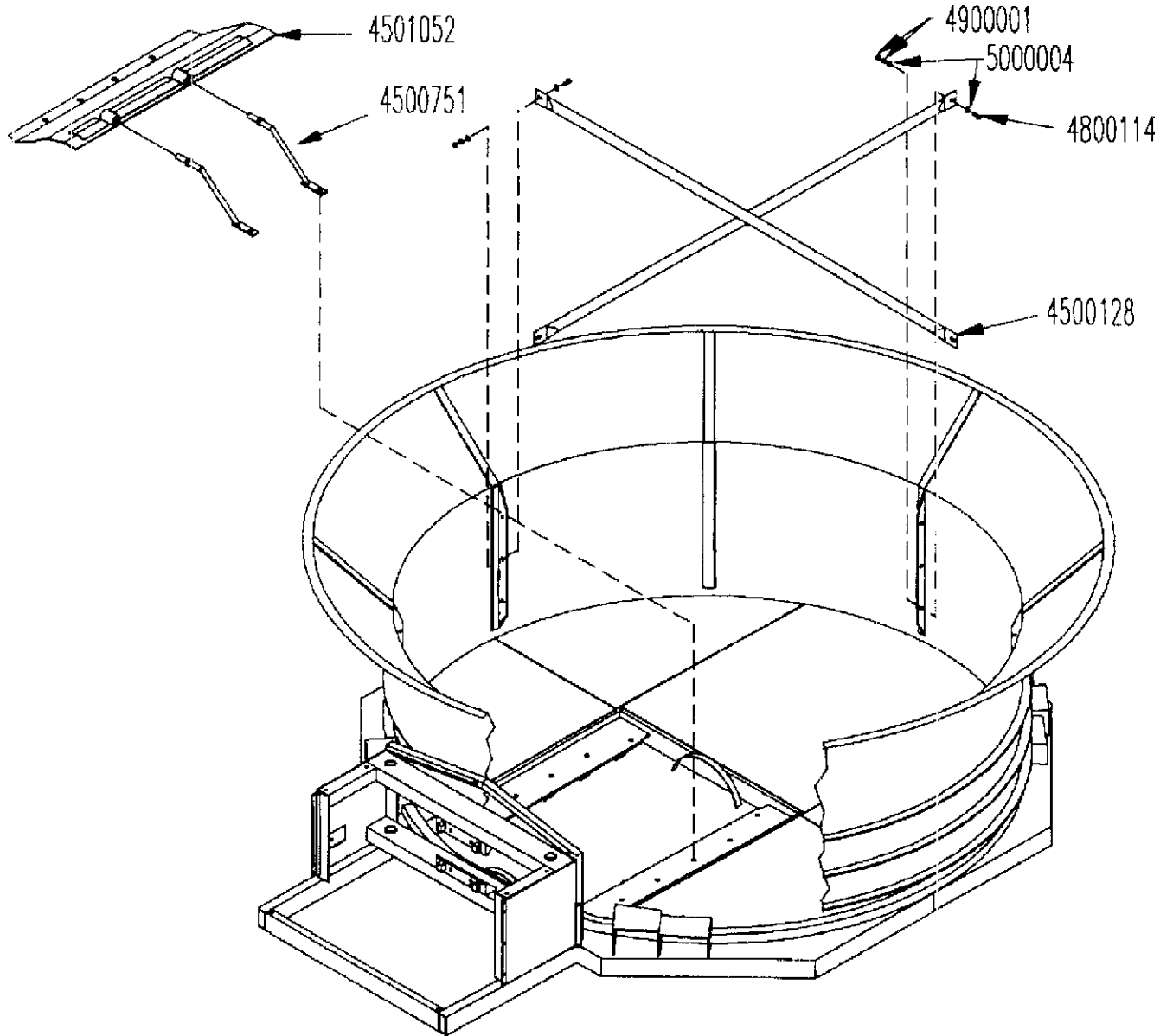

PART	QTY.	PART DESCRIPTION
4501053		OPT\EAR CORN\H1100E
4500128	2	PIPE\CROSS
4500751	2	BRKT\COVER\ROTOR\EARCORN
4501052	1	COVER\ROTOR\EAR CORN
4800114	4	BOLT\HEX\1/2X2
4900001	8	NUT\HEX\1/2\NC
5000004	8	WASH\FLAT\1/2

**OPTION: MILL COVER**

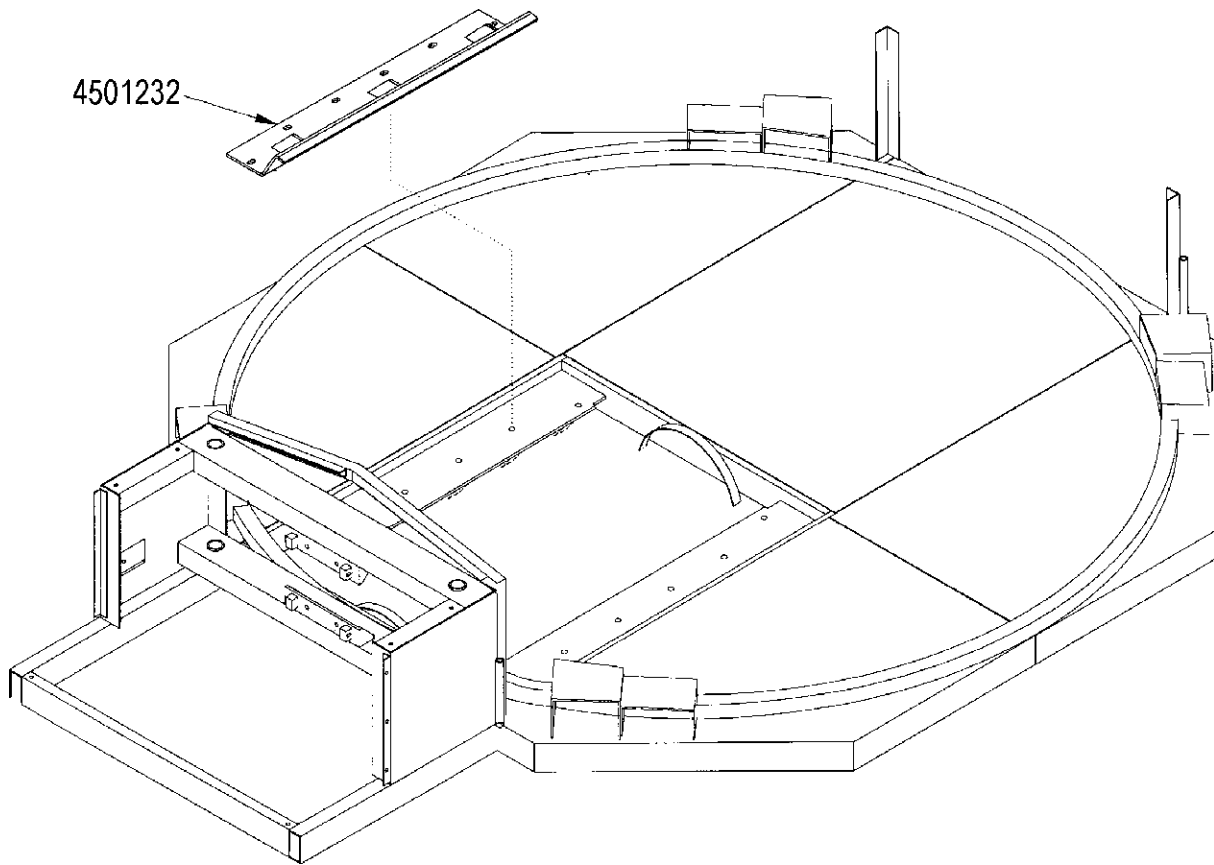

<b>PART</b>	<b>QTY.</b>	<b>PART DESCRIPTION</b>
4501417		PL\GEYSER\ASSY\H1100\INSTALLED
4501232	1	CVR\MILL\H1100E&TILT
4800079	6	BOLT\HEX\5/8X2-1/2
4900012	6	NUT\TPLCK\5/8\NC
5000002	12	WASH\FLAT\5/8



**OPTION: LOOSE HAY GUIDE**

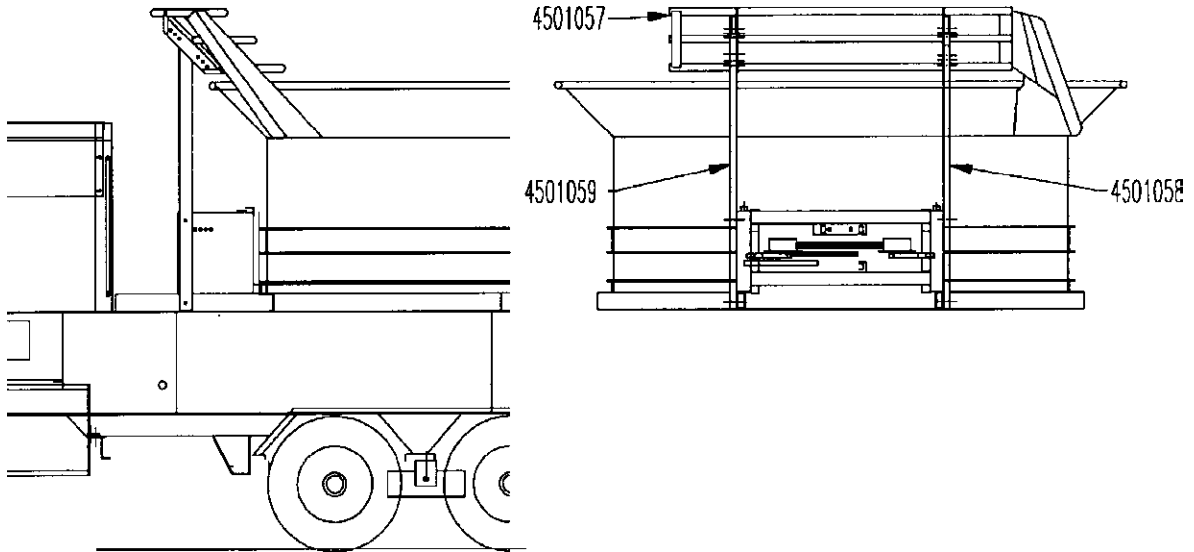

PART	QTY.	PART DESCRIPTION
4501060		OPTN\HAY GUIDE\H1100E
4501057	1	GUIDE\HAY\H1100E
4501058	1	BRKT\GUIDE\HAY\LH\H1100E
4501059	1	BRKT\GUIDE\HAY\RH\H1100E
4800070	6	BOLT\HEX\1/2X2-1/2
4800141	2	BOLT\HEX\1/2X4-1/2
4900001	8	NUT\HEX\1/2\NC
5000004	12	WASH\FLAT\1/2
5000006	8	WASH\LOCK\1/2

**OPTION: CONVEYOR DISCHARGE GUIDE**

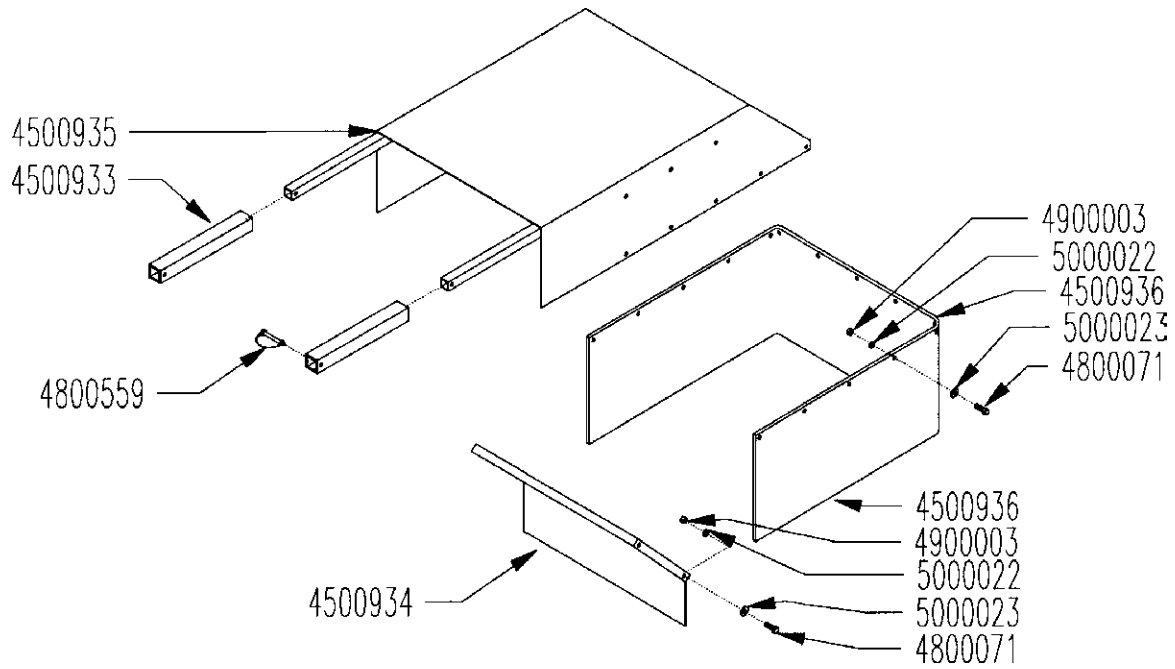

<b>PART</b>	<b>QTY.</b>	<b>PART DESCRIPTION</b>
4500937		GUIDE\MATL\CNVYR\ASSY
4500933	2	MOUNT\GUIDE\MATL\CNVYR\UP
4500934	1	DEFLECTOR\GUIDE\MATL\CNV*
4500935	1	GUIDE\MATL\CNVYR\UPPER
4500936	1	BELT\GUIDE\MATL\CNVYR\UPP
4800071	13	BOLT\HEX\5/16X1-1/4
4800559	2	PIN\LYNCH\5/16X2-1/2\>
4900003	13	NUT\HEX\5/16\NC
5000022	13	WASH\LOCK\5/16
5000023	13	WASH\FLAT\5/16

**OPTION: MILL GRATE**

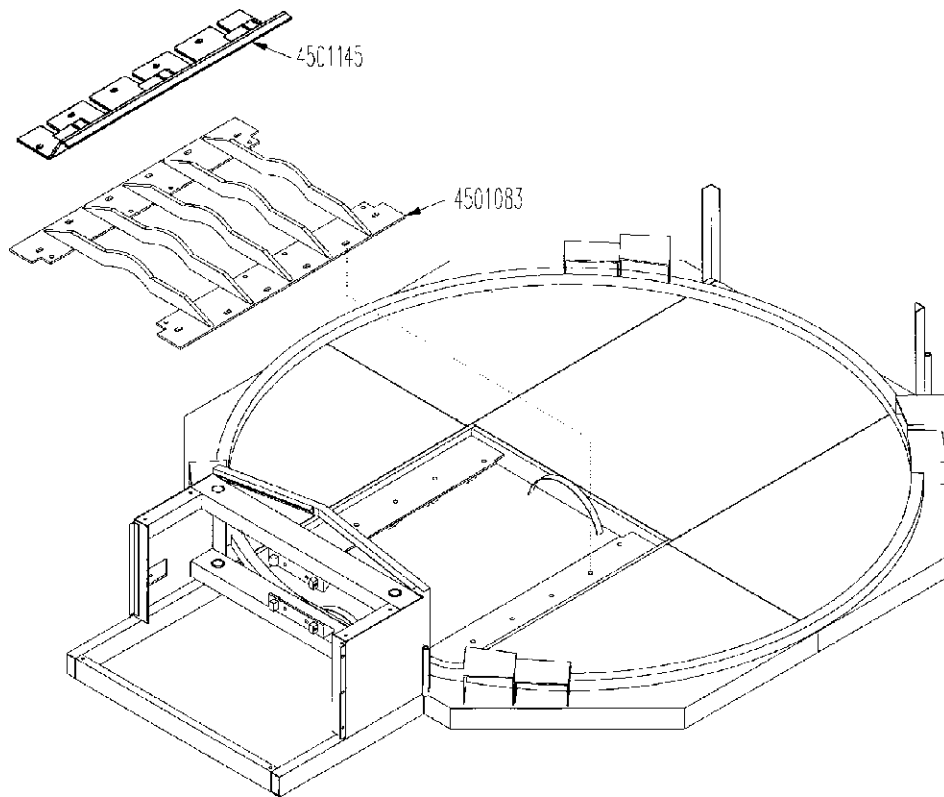

<b>PART</b>	<b>QTY.</b>	<b>PART DESCRIPTION</b>
4501083	1	GRATE\MILL\H1100E&TILT
4703718		GRATE\MILL\LOWERED\H1100\1150\1155
4501145		CVR\MILL\SLTTD\H1100E&TILT

**OPTION: 12 VOLT WORK LIGHTS**

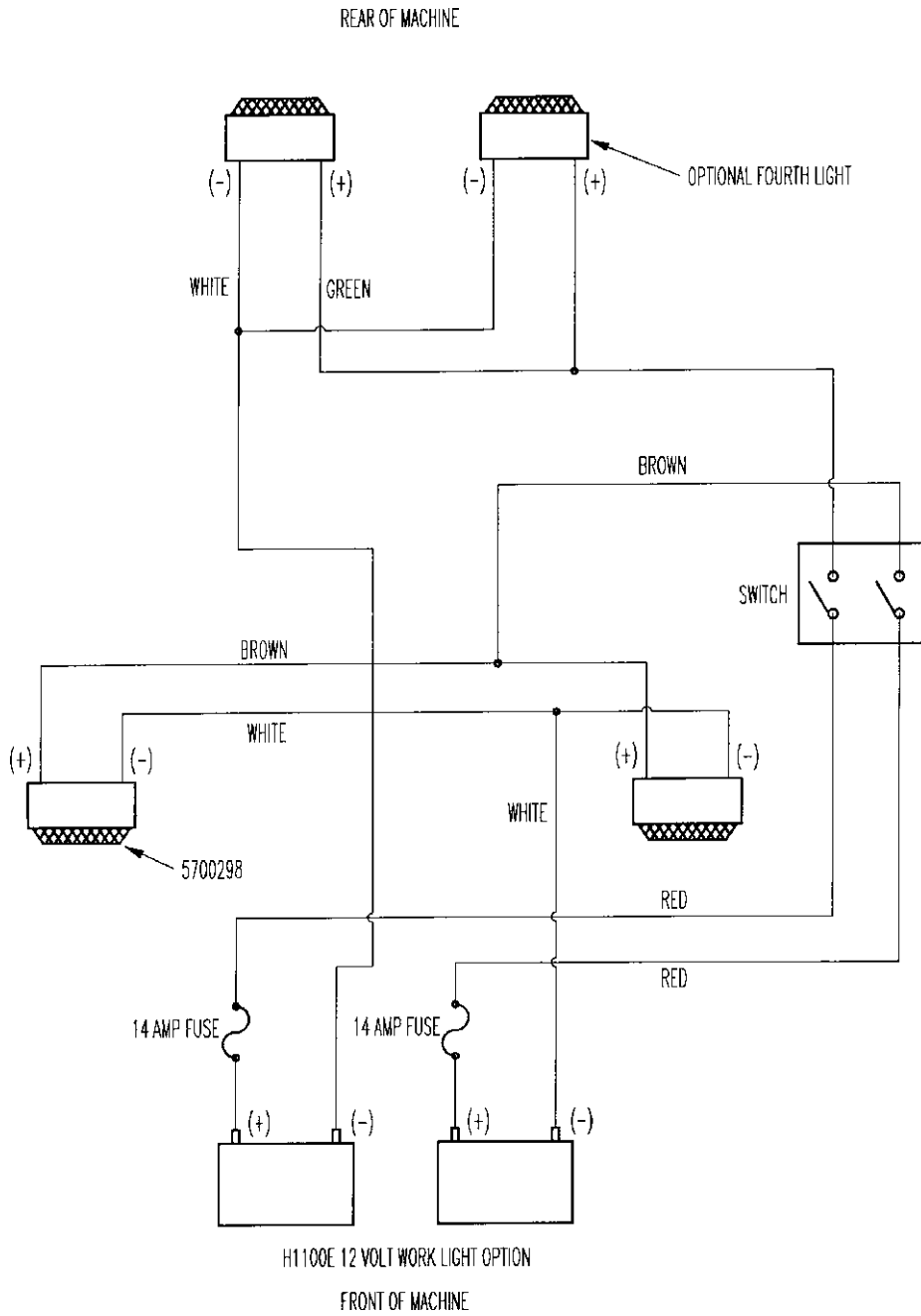

PART	QTY.	PART DESCRIPTION
5700298	3 OR 4	LAMP\HALOGEN\4X6\12VDC

### OPTION: 24 VOLT WORK LIGHTS

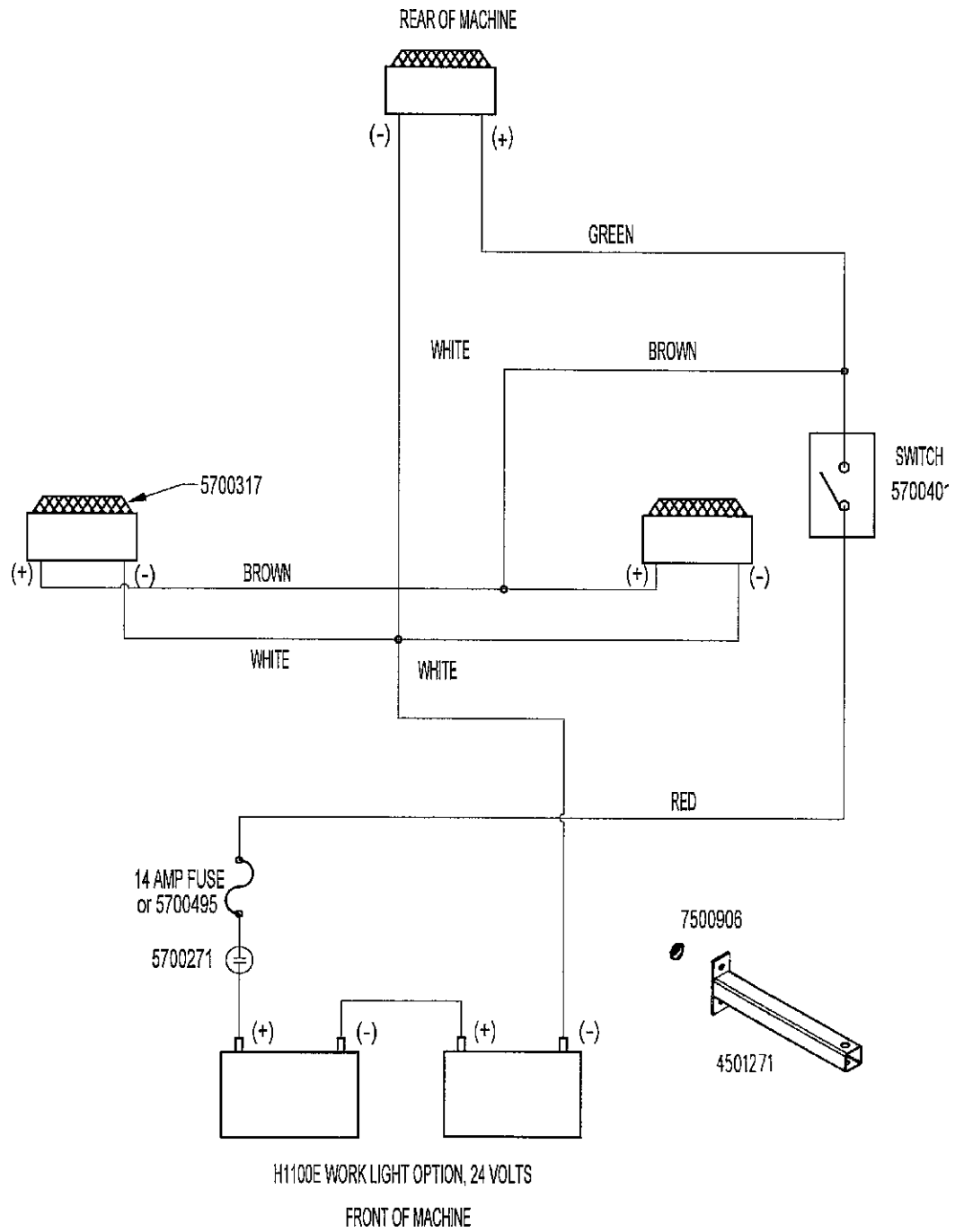

PART	QTY.	PART DESCRIPTION
4501067		OPTN\LIGHTS\WORK\H1100E
4501271	2	MOUNT\LIGHT\FRONT\H1100E
5700271	1	RELAY\CONT:DUTY\24V\ST-88
5700317	3	LAMP\HALOGEN\4X6\24VDC
5700401	1	SWITCH\TGGL\24V
5700495	1	BRKR\CRCT\15A\AUTO\TYPE1\24V
7500906	2	GRMT\RBBR\7\16X1\4IDX1\8T

OPTION: MAGNETIC ROLLER KIT\18\COMPLETE

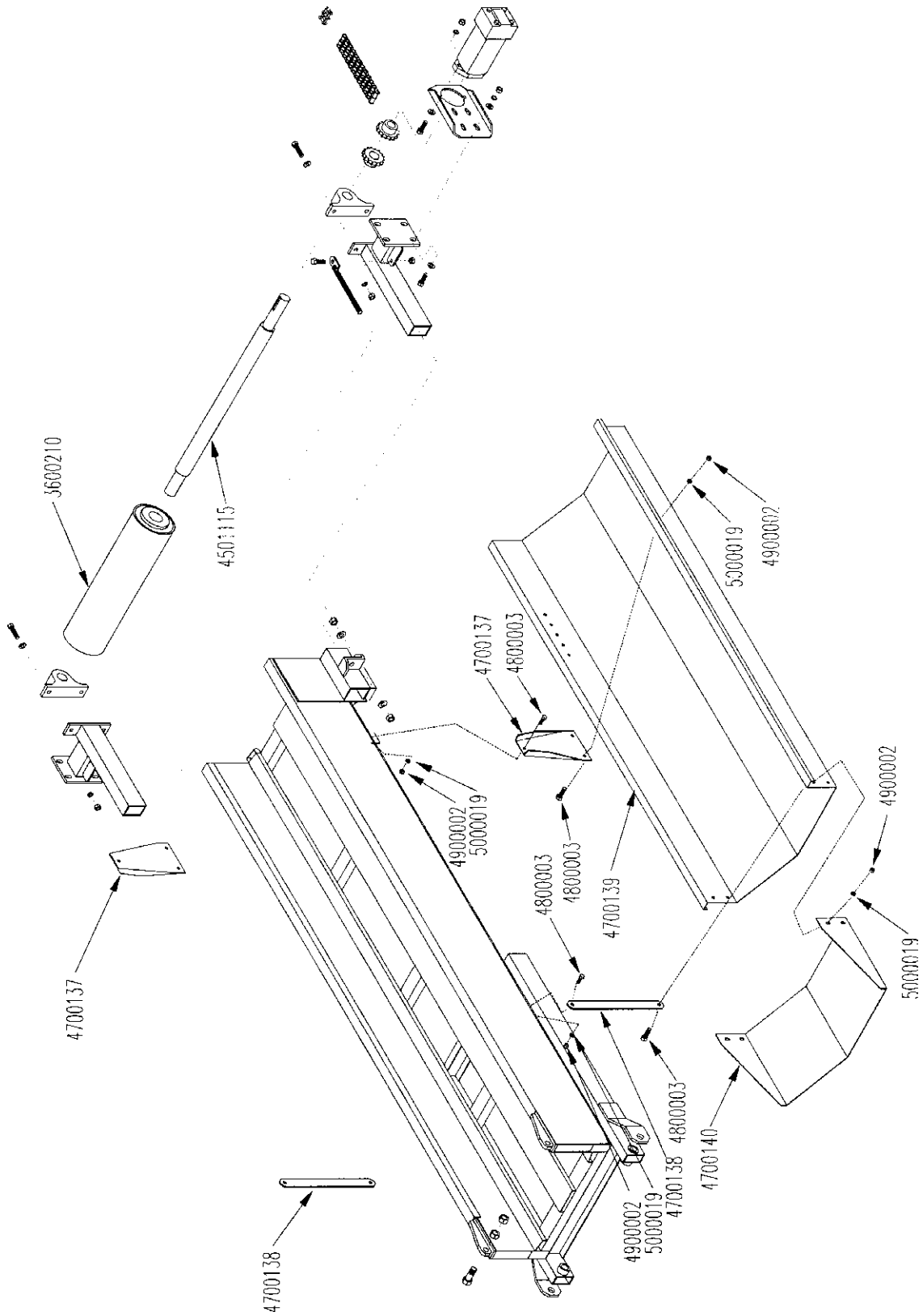

**OPTION: MAGNETIC ROLLER KIT\18\COMPLETE**

<b>PART</b>	<b>QTY.</b>	<b>PART DESCRIPTION</b>
4501098		RLLR\MAG\KIT\COMP\18
3600210	1	6" X 18" MAGNETIC ROLLER
4501115	1	SHAFT\RLLR\MAGNETIC\18"
4700137	2	MNT\CHUTE\REAR
4700138	2	MNT\CHUTE\FRONT
4700139	1	CHUTE\RLLR\MAG
4700140	1	CHUTE\END\SECTION\
4800003	12	BOLT\HEX\3/8X1
4900002	12	NUT\HEX\3/8
5000019	12	WASH\LOCK\3/8

OPTION: AIR COMPRESSOR KIT

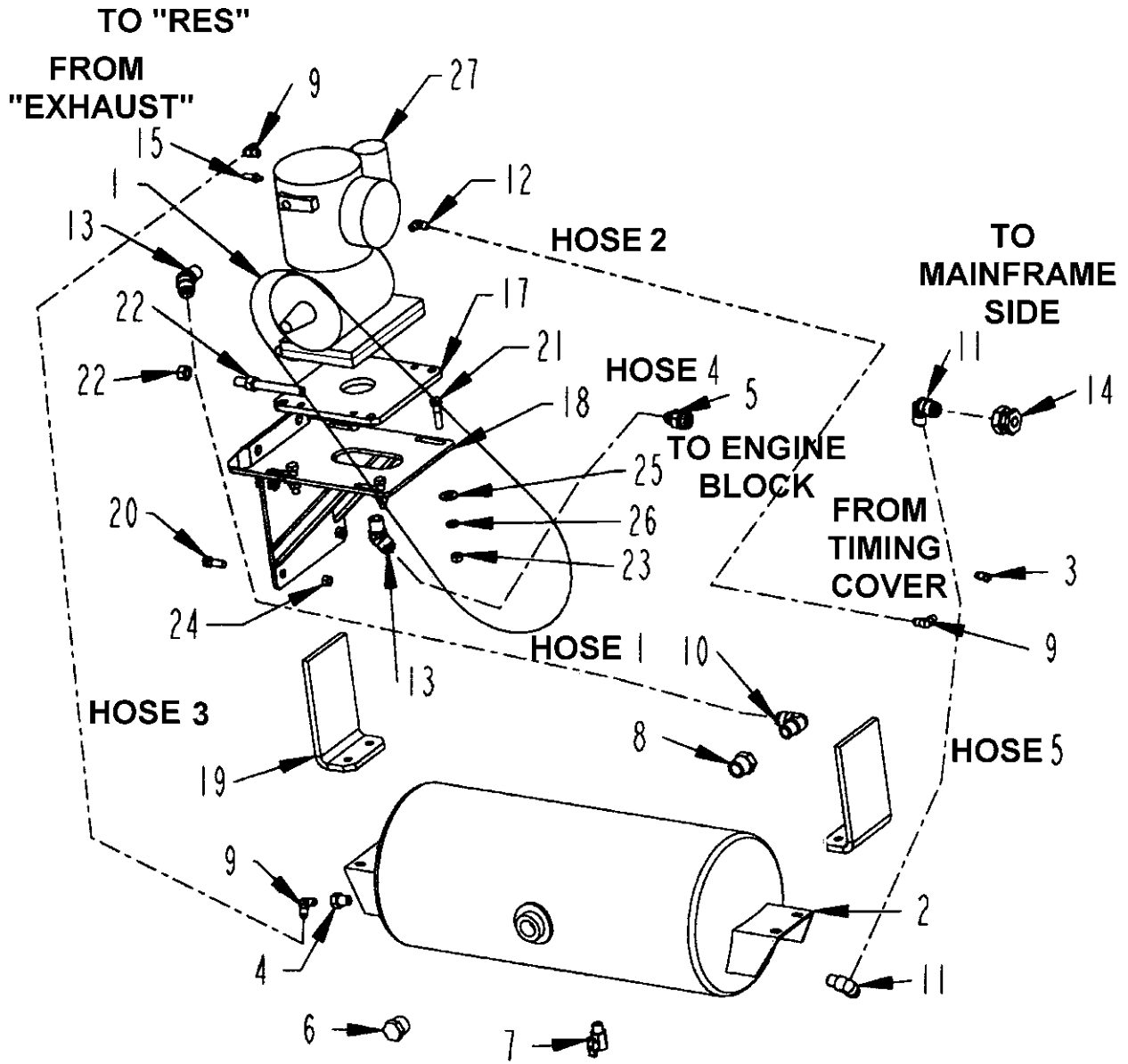



**OPTION: AIR COMPRESSOR KIT**

ITEM	PART	QTY.	PART DESCRIPTION
	4501062	1	OPTN\COMPRESSOR\AIR\H1100E
1	1600039	1	V-BELT\B\62
2	2500909	1	AIR TANK SMALL 2001
3	3800186	1	FTG\AIR\1/8MPX1/8FP\90\ST;EL\BRS
4	3800258	1	FTG\AIR\3/8MPX1/8FP\BUSH\BRS\LW
5	3800328	1	FTG\7/8MORX3/4MJIC\ADPT
6	3800441	1	FTG\3/4MP\PLUG\HEX
7	3800518	1	FTG\AIR\1/4MP\DRAIN\BRS
8	3800617	1	FTG\AIR\3/4MPX1/2FP\BUSH\BRS\LW
9	3800633	3	FTG\AIR\7/16M45FX1/8MP\90
10	3800634	1	FTG\AIR\7/8M45FX1/2MP\90
11	3800635	2	FTG\AIR\3/4M45FX3/8MP\90
12	3800636	1	FTG\AIR\7/16M45FX1/8MP\45
13	3800637	2	FTG\AIR\7/8M45FX1/2MP\45
14	3800640	1	FTG\AIR\3/8FP\BLKHD\BUSH
15	3800641	1	MUFFLER\AIR;VALVE\1/8MP
17	4501071	1	BRKT\SLIDE\TIGHTENER\COMP\AIR
18	4501072	1	BRKT\COMP\AIR\H1100E
19	4501273	2	MNT\AIR_TANK\COMPRESSOR\H1100E
20	4800003	4	BOLT\HEX\3/8X1
21	4800034	4	BOLT\HEX\3/8X1-1/2
22	4900001	4	NUT\HEX\1/2\NC
23	4900002	4	NUT\HEX\3/8\NC
24	4900023	4	NUT\TPLCK\3/8\NC
25	5000001	4	WASH\FLAT\3/8
26	5000019	4	WASH\LOCK\3/8
27	7500728	1	COMP\AIR\BELT-DR\3406

**HOSES**

ITEM	PART	QTY.	PART DESCRIPTION
1	3700503	1	HOSE\TEFLON\7/8F45FX7/8 F45FX60
2	3700506	1	HOSE\AIR;BRK\3/16X32\7/16 F45FX7/16F45F
3	3700507	1	HOSE\AIR;BRK\3/16X56\7/16 F45FX7/16F45F
4	3700508	1	HOSE\AIR;BRK\13/32X48\3/4 F45FX3/4F45F\90D
5	3700509	1	HOSE\AIR;BRK\13/32X100\ 3/4F45FX3/4F45F

**OPTION: RADIO REMOTE**

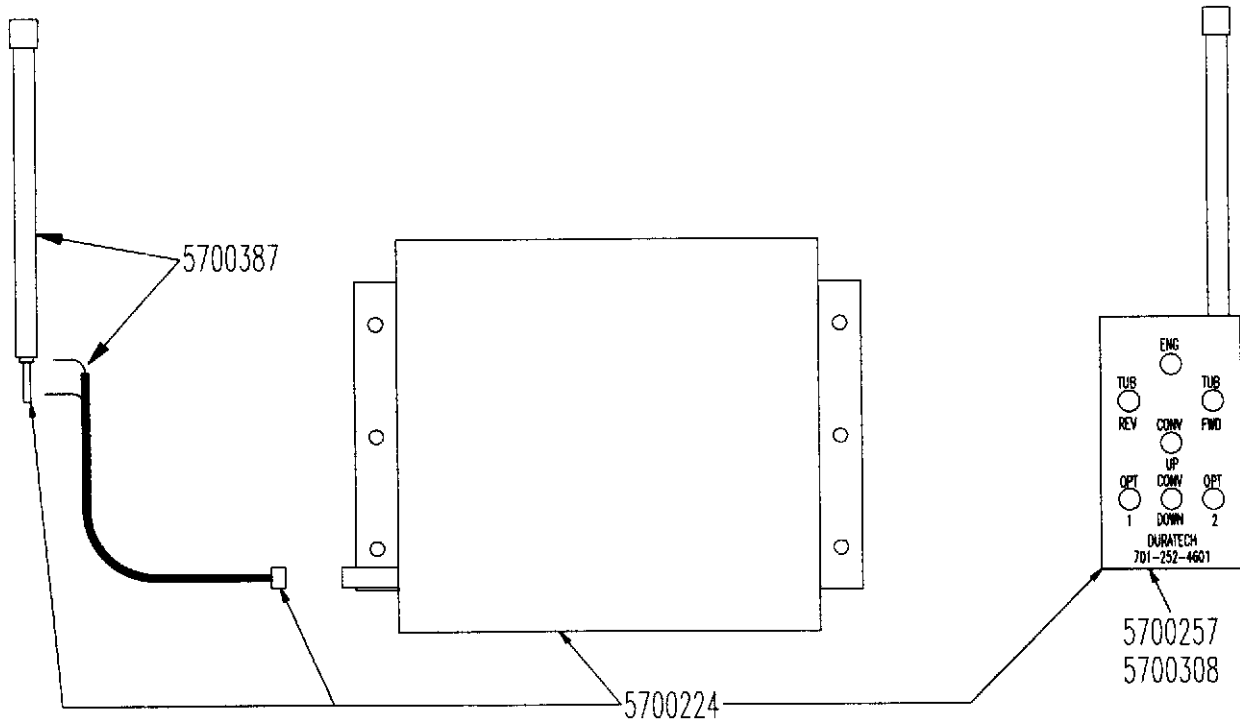

MICROTRONIC'S INC.																			
ADDRESS CODE																			
1	2	3	4	5	6	7	8	9	10	11	12	13	14	15	16	17	18	19	20
A	B	C	D	E	F														
S/N _____																			

BE SURE TO SPECIFY TRANSMITTER CODE LETTER WHEN ORDERING TRANSMITTER

**OPTION: RADIO REMOTE**

<b>PART</b>	<b>QTY.</b>	<b>PART DESCRIPTION</b>
5700224		RADIO\REMOTE\CONTROL\7B\COMPLETE
5700257		RADIO\REMOTE\SENDER\7B\D
5700308		RADIO\REMOTE\SENDER\7B\C
5700387		RADIO\REMOTE\ANTENNA&CABL





